

# CATALOGUE

Diagnostic and service tools

Permanent network monitoring

INspektor®

INBLOX® Modular Diagnostic repeater

PROmanage® and PROscan® Active

Infrastructure components

Troubleshooting

Trainings

Consulting

Individual solutions

Архангельск (8182)63-90-72  
Астана (7172)727-132  
Астрахань (8512)99-46-04  
Барнаул (3852)73-04-60  
Белгород (4722)40-23-64  
Брянск (4832)59-03-52  
Владивосток (423)249-28-31  
Волгоград (844)278-03-48  
Вологда (8172)26-41-59  
Воронеж (473)204-51-73  
Екатеринбург (343)384-55-89  
Иваново (4932)77-34-06

Ижевск (3412)26-03-58  
Иркутск (395)279-98-46  
Казань (843)206-01-48  
Калининград (4012)72-03-81  
Калуга (4842)92-23-67  
Кемерово (3842)65-04-62  
Киров (8332)68-02-04  
Краснодар (861)203-40-90  
Красноярск (391)204-63-61  
Курск (4712)77-13-04  
Липецк (4742)52-20-81  
Киргизия (996)312-96-26-47

Магнитогорск (3519)55-03-13  
Москва (495)268-04-70  
Мурманск (8152)59-64-93  
Набережные Челны (8552)20-53-41  
Нижний Новгород (831)429-08-12  
Новокузнецк (3843)20-46-81  
Новосибирск (383)227-86-73  
Омск (3812)21-46-40  
Орел (4862)44-53-42  
Оренбург (3532)37-68-04  
Пенза (8412)22-31-16  
Казахстан (772)734-952-31

Пермь (342)205-81-47  
Ростов-на-Дону (863)308-18-15  
Рязань (4912)46-61-64  
Самара (846)206-03-16  
Санкт-Петербург (812)309-46-40  
Саратов (845)249-38-78  
Севастополь (8692)22-31-93  
Симферополь (3652)67-13-56  
Смоленск (4812)29-41-54  
Сочи (862)225-72-31  
Ставрополь (8652)20-65-13  
Таджикистан (992)427-82-92-69

Сургут (3462)77-98-35  
Тверь (4822)63-31-35  
Томск (3822)98-41-53  
Тула (4872)74-02-29  
Тюмень (3452)66-21-18  
Ульяновск (8422)24-23-59  
Уфа (347)229-48-12  
Хабаровск (4212)92-98-04  
Челябинск (351)202-03-61  
Череповец (8202)49-02-64  
Ярославль (4852)69-52-93

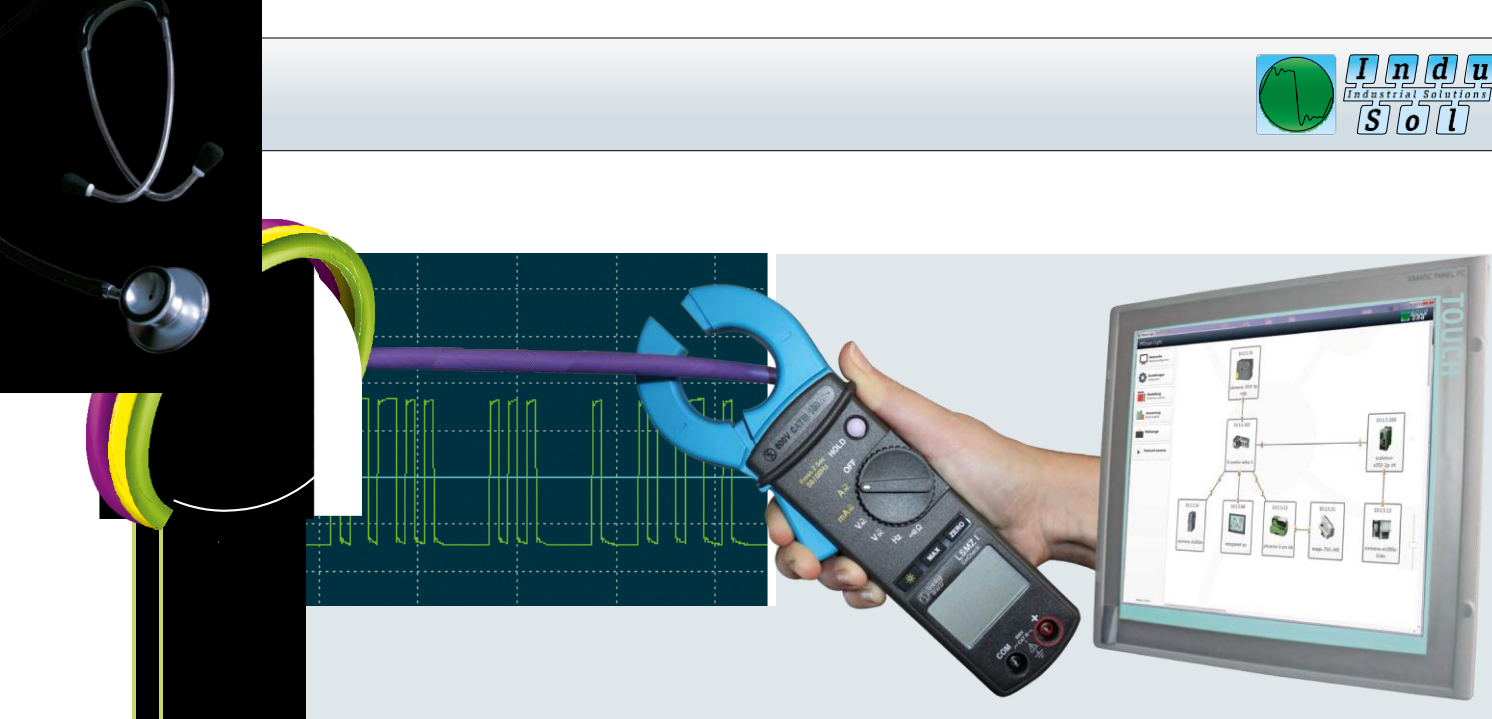

**Control networks!  
Localize bottlenecks!  
Eliminate problems!**

- Tools for comissioning and maintenance
- Permanente network monitoring
- Infrastructure components
- Troubleshooting and fault elimination and in industrial networks
- Acceptance and certification of networks
- Training /Workshop

<b>The Company</b>	<b>sheet</b>	
Philosophy	4	
Corporate development	5	
<b>1. Diagnostic and service tools</b>	<b>7</b>	<b>1</b>
PROFIBUS DP / PA	8	
Ethernet / PROFINET	18	
ASi	26	
CAN / DeviceNet / SafetyBUS p	29	
universal device	30	
Accessories	32	
<b>2. Permanent network monitoring (PNM)</b>	<b>37</b>	<b>2</b>
Introduction permanent network monitoring	38	
Decentralized data logger PROFIBUS-INspektor®	40	
StarterKIT PROFIBUS-INspektor®	42	
INBLOX® Modularer INspektor®	43	
Decentralized data logger PROFINet-INspektor®	51	
StarterKIT PROFINet-INspektor®	53	
Decentralized data logger ASi-INspektor®	54	
Decentralized data logger CB-INspektor®	55	
Network monitoring software PROmanage®	57	
Sample configuration permanent network monitoring	58	
OPC Server	60	
Topology software PROscan® Active	61	
<b>3. Infrastructure components</b>	<b>63</b>	<b>3</b>
PROFIBUS DP / PA	64	
Ethernet / PROFINET	109	
ASi	125	
CAN / DeviceNet / SafetyBUS p	135	
<b>4. Service - Measurement</b>	<b>145</b>	<b>4</b>
PROFIBUS / ASi / CAN / DeviceNet / SafetyBUS p	146	
Ethernet / PROFINET	147	
InterBus	148	
LWL	149	
EMV	150	
Wireless	152	
<b>5. Service - Training</b>	<b>153</b>	<b>5</b>
Training PROFIBUS	154	
Training CAN / DeviceNet / SafetyBUS p	155	
Training Ethernet	156	
Training PROFINET	157	
Training EMV	158	
Training WLAN	159	

Philosophie



„Only good staff make good stuff.“



Managing Director K.-H. Richter  
Marketing & Sales



Managing Director René Heidl  
Engineering & Development

The engagement

- Participation in the „Association of German Engineers“/ „The Association for Electrical, Electronic & Information Technologies in GMA Subject Committee 6.15“
- Member of the „German Research Society of Automation and Microelectronics“
- Member of the „PNO“
- Member of „Dachverband PROFIBUS & PROFINET International“
- Member of EMC Competence Network
- Member of AS International Association e.V.
- Member of the Club SafetyBUS p
- Advisory Council on the technical committee of the „Cooperative Education“ Gera
- Member of Chamber of Industry and Commerce Eastern Thuringia

The Team

Customer-oriented solutions, excellent quality and cost efficiency are our aims. We understand service as performance, competence and flexibility. Trust, openness and mutual respect are the basis of successful cooperation.

Teamwork and communication create transparency of knowledge and are prerequisites for professional advice. We serve our customers and constructive criticism is reason to improve.

The Team of Entrepreneurs

A dual leadership of an ingenious inventor and engineer and a sales expert with a grasp for market and market potentials. A management team with an unrelenting will to succeed not losing sight of reality.

„Our staff is our asset and our product is our know-how based on expertise and experience. It is regarded as imperative to safeguard and expand it continuously...“ R. Heidl (speech at 5th company's anniversary)

Our Mission

As a manufacturer-independent, cross-sectoral technology company we assess objectively the quality and stability of industrial data networks. A reliable communication is the basis of continuous production. Safe and trouble-free operation of machines and plants are the result of our work.

We define state quantities and make quality measurable.

We make our know-how and experience transparent and are glad to pass it on to our customers.

The cyclical or permanent testing of the network status should be the desire of every design engineer, maintenance man and also service technician.

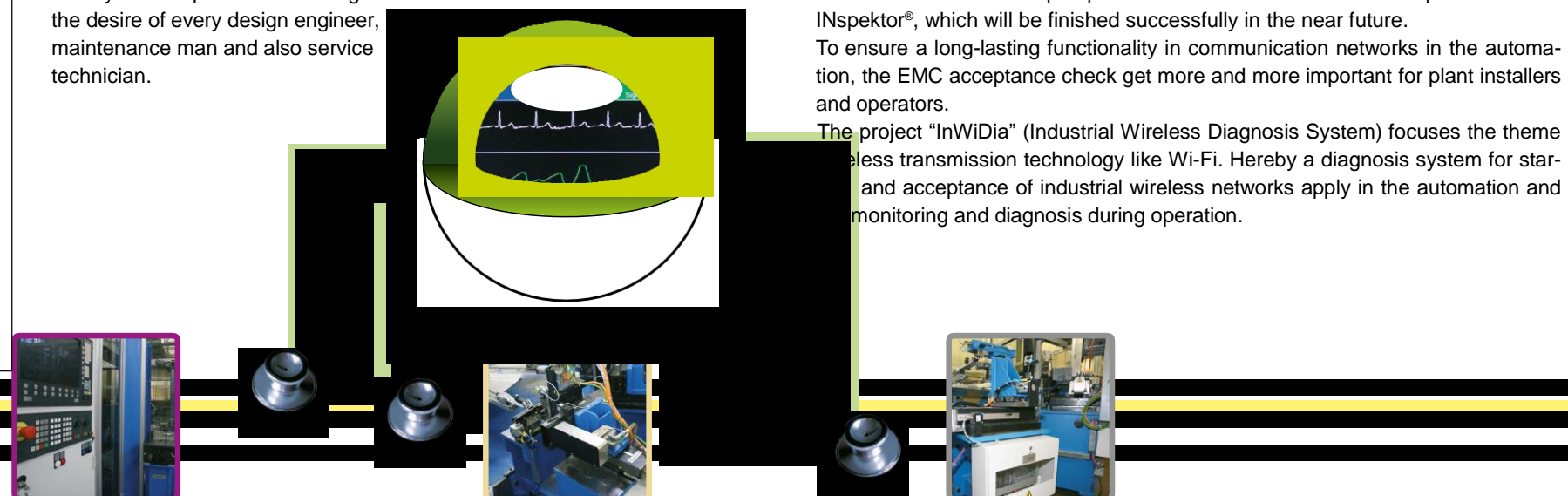

Corporate Development

The beginning

A small team of specialists with years of experience in fieldbus technology discovered the importance and thus the significance of the metrological proof of the data communication quality. The statement „It works!“ that used to be binding could no longer bear up against the quality requirements of many users.

A DUO founded Indu-Sol GmbH in January 2002 having the sale of diagnostic tools in mind, and encountered in the early days many a misunderstanding and disbelief when issues such as wear and tear and ageing of fieldbus equipment were discussed. Today Indu-Sol is firmly established on market as a leading service provider for fieldbus diagnosis.

Competence in the field, sales skills and customers' confidence have made Indu-Sol an important partner of planners, maintenance engineers and service technicians of major industries in Germany.

The presence

Until today Indu-Sol has grown permanently and seems to expand furthermore. At the start of 2013 we listed 75 employees, including 15 measurement engineers, who work worldwide as service provider for the export industry. Indu-Sol's expertise is in great demand all around the world. The experienced company staff present products and developments in a practice-oriented environment and perform trainings directly at the plant. In addition they give advices and recommendations concerning planning and installation of automated production lines and prepare specification sheets.

As a member of the VDI/VDE working groups and the relevant fieldbus organizations Indu-Sol can pass on its years of experience and the know-how to a broad public. With the preparation of the VDI/VDE Guideline 2184 „reliable operation and maintenance of fieldbus systems“ an important initial step in the right direction was done.

Because of constantly growing networks and automation a permanent monitoring and a continuing status analysis of the communication quality were already essential years ago. Therefore Indu-Sol developed the INspektor® family. As a first project the simple and easy-to-use diagnostic tool PROFIBUS stand-alone INspektor® arised, which could well be compared with the medical ECG. Thanks to a hardware-integrated web server the network status can be displayed without additional software on any PC, via internet browser and device-related as a matrix. Traffic light colours highlight the status and allow pursuing intuitively a quick and targeted maintenance strategy. After that further INspektor® tools were developed for the fieldbus systems ASi, CAN and PROFIBUS PA. The development of the PROFINET INspektor® for the more and more utilized technology PROFINET could be successfully finished as well. In this way the INspektor® family spirit, including the network management software PROmanage® satisfies the need for more central monitoring of a multitude of networks of different reports.

The future

Indu-Sol looks beyond the end of the nose, respectively the fieldbus-intern communication and has its focus on the fieldbus relevant environment since a long time. The here detected faults caused of Electromagnetic Compatibility (EMC) were the basis for a deep exploration of this field and the development of EMV INspektor®, which will be finished successfully in the near future.

To ensure a long-lasting functionality in communication networks in the automation, the EMC acceptance check get more and more important for plant installers and operators.

The project „InWiDia“ (Industrial Wireless Diagnosis System) focuses the theme wireless transmission technology like Wi-Fi. Hereby a diagnosis system for start-up and acceptance of industrial wireless networks apply in the automation and monitoring and diagnosis during operation.

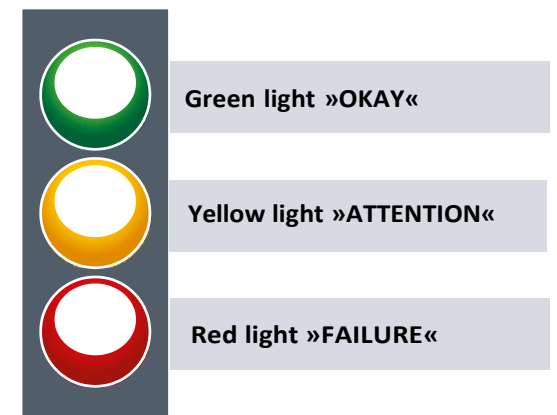

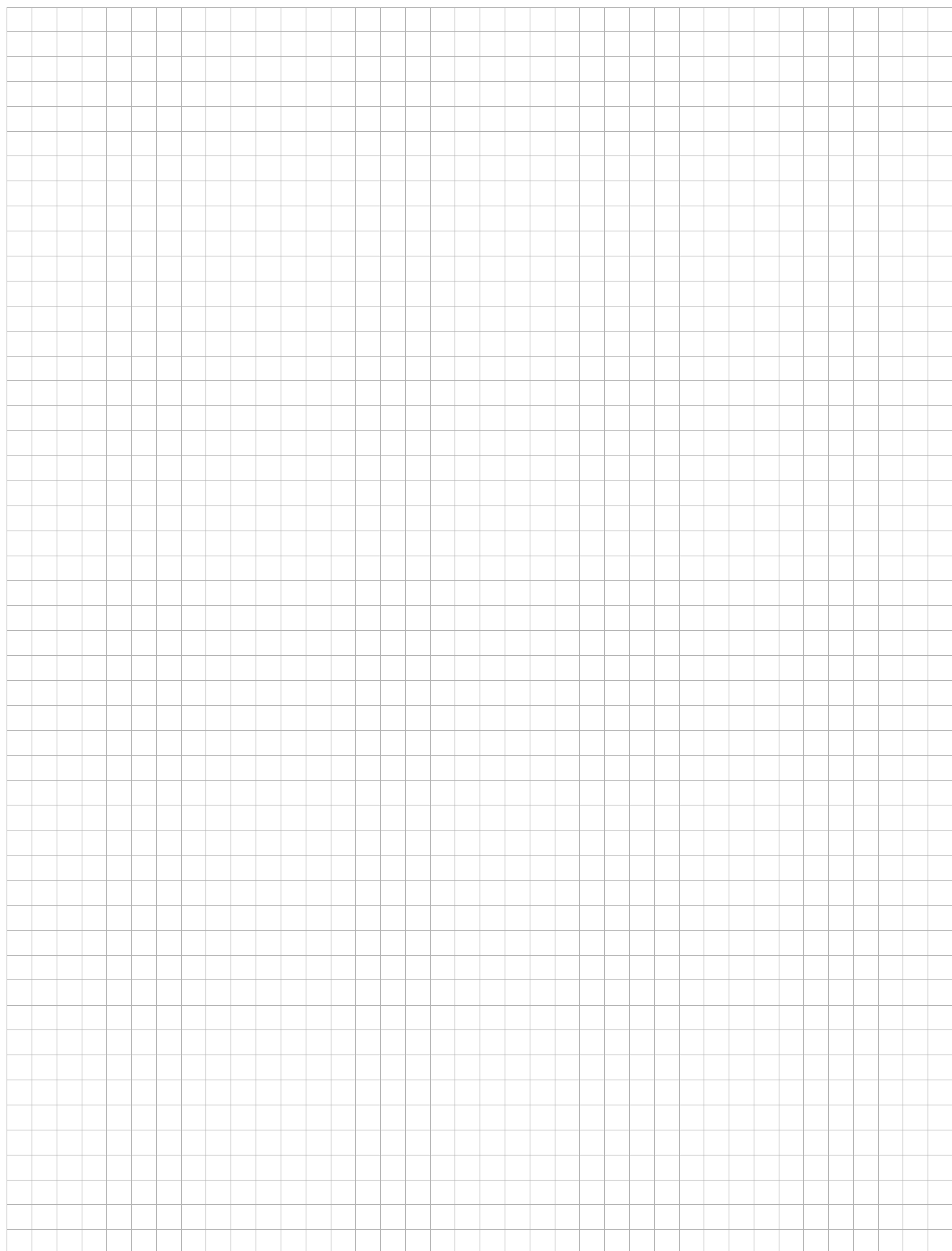

**1. Diagnostic and service tools**

sheet

**PROFIBUS DP / PA**

8

Quality tester PROFITM Professional

8

Line tester PROFtest II XL

10

Logic tester PROFIBUS-INSpektor®

11

PROFIBUS Diagnostic-Set

13

INBLOX® Modularer INSpektor®

14

Universal tester DM-AM-Kit

16

Universal tester PAtest

17

**Ethernet / PROFINET**

18

Introduction Ethernet

18

Topology software PROscan® Active

20

Logic tester PROFINet-INSpektor®

21

Line tester ETHERtest V4

22

Line tester ETHERtest Light

23

PROFINET Diagnostic-Set

24

Active measuring point ETMA

25

**ASi**

26

Quality tester ASi View

26

Logic tester ASi-INSpektor®

27

**CAN / DeviceNet / SafetyBUS p**

28

Quality tester CANBUSview XL III

28

Logic tester CB-INSpektor®

29

**Universal device**

30

leakage current clamp EmCheck® LSMZ I

30

Mesh resistance measuring clamp EmCheck® MWMZ I

31

Accessories

32

**PROFIBUS**

- special-purpose measuring and programming adapter

32

- PROFtest II XL measuring adapter / connecting cable

33

**Universal**

- Mobile power supply unit MoSt

34

- Fast Connect Stripping Tool

35

- Topology plan software TOPOCAD

36

## Quality tester PROFI-TM Professional

### Function

The **PROFI-TM Professional** is a tool for determining the physical as well as the logical communications quality of the data exchange in PROFIBUS networks.

The largely reactionless connection of the hardware to the PROFIBUS network is rendered by the adapter supplied. Thus, the communication quality can be analysed online while the system is running.

The device can be operated both autarkically (without PC) and with a PC. The software records and displays all measuring and test results on the PC.

The software is simple and easy to understand. A clear menu navigation makes it possible to change between a diagnosis mode and the expert mode.

### Physical quality determination

#### Signal quality

The PROFIBUS runs by using a differential voltage signal transmitting the logical telegram contents to the lines A and B. The amount of the voltage difference as well as the shapes of the signals is a measure for the physical transmission quality or the signal quality, respectively. Every bit is scanned sixteen fold. The evaluation is based on the 6/16th of the total width. Thus, the signal transitions effects are not included in the evaluation. All quality values determined are shown as a bar chart and non-realized.

#### Signal to noise ratio

The signal to noise ration indicates the shortest distance between a logic „0“ and the logic“1“. It shows how far the signal of a device is affected by external interferences or signal fluctuations.

The signal to noise ration helps to recognize sporadic physical errors.

#### Oscilloscope

An in-depth analysis of the PROFIBUS signal can be done by a fully operative digital oscilloscope. Symmetric interferences can be shown and analysed by a separate representation of the A and B line signals.

#### Trend

Trend recordings over a longer period of time make it possible to record very rare PROFIBUS errors. Device-related and at fixed intervals the quality value and critical events, such as error telegrams, repeat telegrams, diagnoses and device failures can be evaluated and displayed.



PROFI-TM Professional



Independent operation

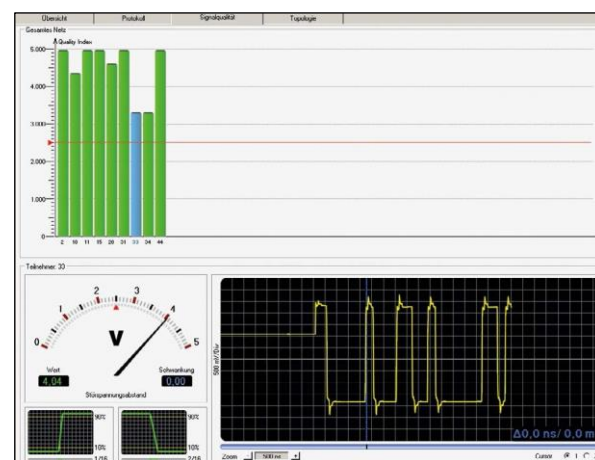

Assessment of signal quality

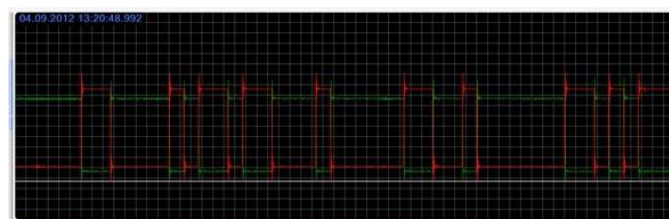

Integrated oscilloscope

## Quality tester PROFI-TM Professional

### Logical quality analysis

#### Diagnosis mode

In the Diagnosis mode all bus devices are shown in form of a tree, including address, module name and device symbol (access through GSD file). The condition of the device concerned can be quickly evaluated by the colour highlighting of each device (green, yellow, red). Besides the colouring the events are shown in plain text and provided with a time stamp.

#### Telegram mode

The telegram mode extends the range of analyses. A large number of filters and triggers is available to analyse the data traffic in terms of events but also certain data content.

#### Master simulator

The integrated master simulator is designed to determine the actually wired bus topology and analyse the signal quality of the connected bus devices. The master simulator is used in the offline mode without SPC.

### Technical data

- PROFIBUS interface: 9-pole sub-D
- Voltage supply: 9.6 kbps - 12 Mbps
- USB interface: 24 VDC +/-20%, approx. 0.5A, via external power supply V2.0
- Dimensions (H x W x D): 35 x 170 x 110 mm
- Protective system: IP20
- Operating temperature: 0°C to +50 °C
- Storage temperature: -20 °C to +70 °C
- Conformity: CE, FCC, VCCI

### Scope of delivery

- PROFI-TM Professional Hardware
- Power supply 100 - 240 VAC / 24VDC, 0,5A
- Direct connection cable for power supply 24VDC
- PROFIBUS accessories
- USB cable 3m
- CD-ROM with drivers and PC software
- Manual + Quick Start Guide

### Ordering details

**PROFI-TM Professional** Art. No. **110010004**

### Accessories

**MoSt** Art. No. **110020023**

**Bus disconnecter** Art. No. **110020004**

**M12 Y Measuring adapter** Art. No. **110020018**

**Adapter set M12** Art. No. **110020015**

**Adapter cable PB-D-SUB 1** Art. No. **110020013**

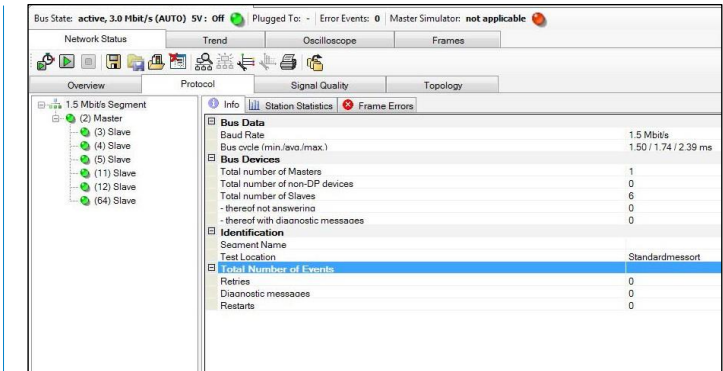

Diagnosis mode

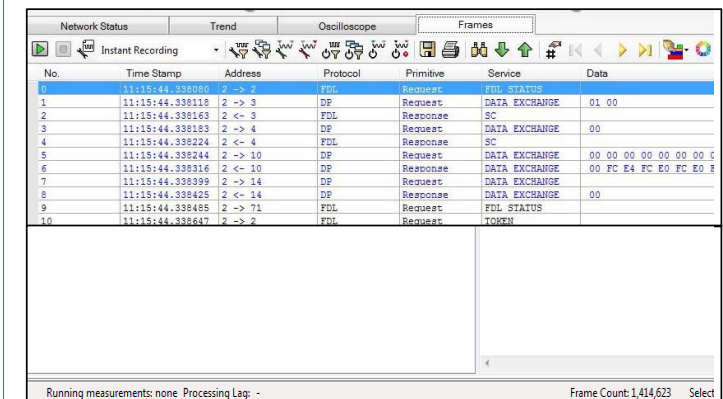

Telegram mode

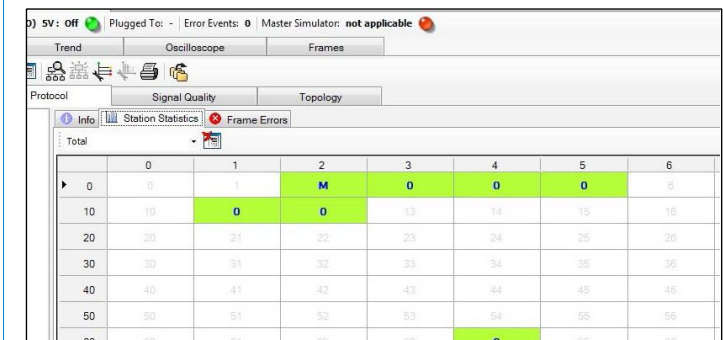

Device matrix incl. state display

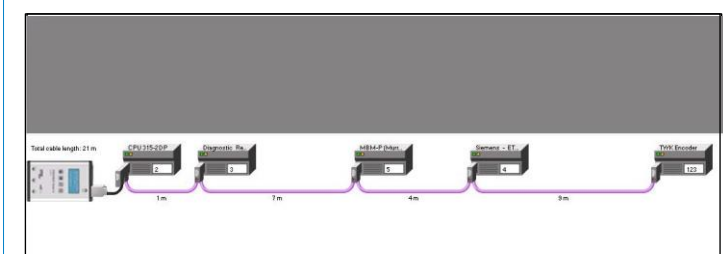

Topology scan

### Line tester PROFtest II XL

#### Function

**PROFtest II** is a handy and easy-to-handle tool for checking the correct cabling in PROFIBUS networks with RS-485 transmission technique. By using PROFtest II, you will have a quick and simple overview on the actual wiring state either when starting up the system or carrying out a maintenance job. Measurements are normally performed off-line, i.e. without using the PLC/PROFIBUS master. So PROFtest II is looped through either at the start or the end of the line (see fig.2). This step is easy to handle and menu driven. To operate PROFtest II, you need not require any special expertise. The most frequently used menu point is the sheer line test. The measurement is carried out in three steps as follows:

- test without a termination
- test with one termination
- test with two terminations

The error is directly displayed with the line length pinpointed in meters measured from the measuring position. The detected data is represented in a measuring record which can be stored in the device or read out by a PC terminal program (see fig. 3). When using PROFtest II XXL version, a master function has been integrated, where as PROFtest II XXL-Online features an additional XXL-online function.

#### Technical data

- Applicable for PROFIBUS using RS-485 transmission technique
- Power supply via either supplied accumulators or power pack
- Baud rate: 9,6 kbps to 12 Mbps
- Dimensions (L x W x H): 230 x 98 x 53 mm

#### Measuring results - Fault messages

- Display of actually laid line length
- Baud rate scan
- Line impedance measurement
- Correct termination
- Line interruption
- Shield interruption
- Mixed-up lines A-B
- Short circuit line A-B
- Short of line A/B - shield
- Using wrong line types
- Determining reflections
- Non-admissible spur line lengths
- List of all devices accessible at bus
- Transmission / Receiving level

#### Scope of Delivery

- Plastic transport case
- PROFtest II
- Adapter for mains operation plus two rechargeable batteries
- Battery charger appropriate for global use
- Several adaptors for PROFIBUS connection
- PROFtest II manual

Ordering details	Art. No.
PROFtest II XL - basic device	110010005
Extension DP- master function	110010007
Extension online function	110010008
Extension DP-master- u. online function	110010006



PROFtest II XL



Measurement

Analysis result for test without termination  
No error !

Irregularity A <-> B not determinable  
Irregularity A <-> shield not determinable  
Irregularity B <-> shield not determinable  
Breakout or impedance change not determinable  
Cable break not determinable  
Cable OK  
Impedance approx. 145 ohm  
Cable length approx. 159 m

Measurement report

### Logic tester PROFIBUS-INSpektor®

#### Function

Besides the function of a passive data logger the **PROFIBUS-INSpektor®** can also be used as fully-fledged measuring device. The necessary hardware is already integrated in the PB-INSpektor®, and the telegram analysis software is installed on the external PC). The contact between the PB-INSpektor® and the bus is rendered through an active programming cable APKA (Art. No.: 110040001). The connection to the software (PC, PG, laptop) is accomplished by a standardized USB connection. The PROFIBUS INSpektor® inspects the logical data exchange on a permanent basis. Quality-related events, such as:

- error telegrams
- repeat telegrams
- device diagnostics (internal, external)
- restarts
- bus cycle time

are analysed, stored, evaluated and graphically represented in a chronological sequence for every device. By setting of threshold values faults can be automatically detected as an early warning. A floating contact enables visual and acoustic alarms. It is also possible to activate the USB port thus facilitating a thorough logic analysis (PROFIBUS INSpektor® Comfort Line).

#### Technical data

- Voltage supply: 24 VDC +/-20 %, typ. 0.3 A
- PROFIBUS
  - Protocols: DP, DPV1, FMS, MPI
  - Connection: 9-pole sub-D
  - Baud rate: 9.6 kbps to 12 Mbps
- Ethernet
  - Baud rate: 100 Mbps / 10 Mbps
  - Connection: RJ45

#### General data

- Installation: 35 mm DIN top-hat rail
- Dimensions (H x W x D): 131 x 47 x 111 mm
- Protective system: IP20
- Ambient temperature: 5 °C to 70 °C
- Storage temperature: -20 °C to 70 °C

#### Scope of delivery

- PROFIBUS-INSpektor®
- Power pack
- Active programming cable APKA II
- Cross over cable (5 m)
- Patch cable
- Line set 24V/230V
- Carrying case
- Manual

Ordering details	Art. No.
PROFIBUS-INSpektor® Basic-Line	124010000
StarterKIT I (incl. Basic-Line)	124010006
StarterKIT IV (incl. Comfort-Line Plus)	124010009



PROFIBUS-INSpektor®

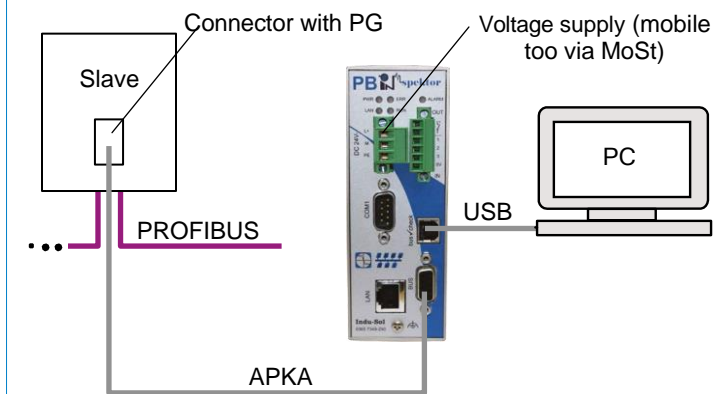

Connection example



StarterKIT PROFIBUS-INSpektor®

### Additional feature logic tester

#### Diagnosis Mode

The diagnosis mode shows all bus devices as a hierarchic structure including address, module name and device symbol (access through GSD file). The coloured background of every device (green, yellow, red) enables an immediate evaluation of the device status. In addition to the coloured signals the events are shown as plain text provided with a time stamp.

Slave 10	
Zeitpunkt	Ereignis
12.02.2008 11:00:14.799723	Slave 10 erkannt
12.02.2008 11:00:14.799723	Slave 10 meldet Diagnose
12.02.2008 11:00:29.670216	Slave 10 antwortet nicht (wird parametrier)
12.02.2008 11:00:29.673601	Slave 10 wird parametrier
12.02.2008 11:00:29.677208	Slave 10 meldet Konfigurationsfehler
12.02.2008 11:00:29.680664	Slave 10 meldet Diagnose

#### Telegram Mode

By the telegram mode it is possible to record all telegrams in PROFIBUS DP. A distinction is made between instant recording on the one hand and long-term recording on the other. An event-oriented start of recording is possible in both modes by specifically setting filters and triggers.

#### Instant Recording

Instant recording is convenient if you want to get a quick overview on the telegram traffic or do different bus analyses interactively. In this mode the recorded telegrams are stored in a buffer of the PC memory and can be viewed as snapshots during recording already (by pressing the space bar). The size of the buffer can be adjusted. As soon as the buffer is full recording stops or changes to ring buffer mode depending on the adjustment. The degree of buffer utilization is shown by a bar in the status line of the Trace mode.

#### Long-term Recording

In this mode telegrams are recorded over a longer period of time and stored in one or multiple files to be viewed and analysed some time later. While recording a window on the right edge of the screen indicates the file in recording currently takes place, the data quantity and how many telegrams have been recorded already and the time since recording started.

#### Advantages

- Gathering of and clear arrangement of the PROFIBUS network structure including all active devices
- Thorough online analysis of all major parameters of the network, PROFIBUS masters and all connected slaves
- Efficient recording and representation filters
- Various triggering possibilities
- Telegram decoding for FDL, DP, DP-V1 and DP-V2
- Telegram recording, incl. long-term recording
- Intuitive user interface in German and English

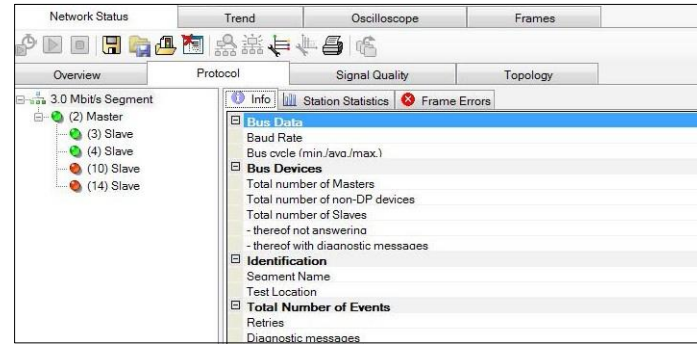

Diagnosis mode with live list

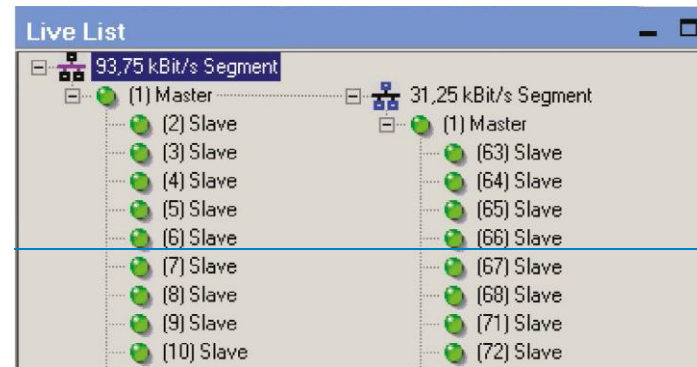

Live list (DP / PA communication)

Address	Protocol	Primitive	Service	Data
-> 2	FDL	Request	FDL STATUS	
-> 3	DP	Request	DATA EXCHANGE	01 00
<- 3	FDL	Response	SC	
-> 4	DP	Request	DATA EXCHANGE	00
<- 4	FDL	Response	SC	
-> 10	DP	Request	DATA EXCHANGE	00 00 00 00 00 00 00 00
<- 10	DP	Response	DATA EXCHANGE	00 FC E4 FC E0 FC E0 FC E4
-> 14	DP	Request	DATA EXCHANGE	00
<- 14	DP	Response	DATA EXCHANGE	00
-> 71	FDL	Request	FDL STATUS	
-> 2	FDL	Request	TOKEN	
-> 2	FDL	Request	FDL STATUS	
-> 2	FDL	Request	FDL STATUS	
-> 2	FDL	Request	FDL STATUS	
-> 2	FDL	Request	FDL STATUS	
-> 2	FDL	Request	FDL STATUS	
-> 2	FDL	Request	FDL STATUS	
-> 2	FDL	Request	FDL STATUS	

Incident-based telegram recordings

Total	0	1	2	3	4	5	6
0	0	1	M	0	0	5	6
10	0	11	12	13	0	15	16
20	20	21	22	23	24	25	26
30	30	31	32	33	34	35	36
40	40	41	42	43	44	45	46
50	50	51	52	53	54	55	56
60	60	61	62	63	64	65	66

Device matrix with status indication

### PROFIBUS Diagnostic-Set

#### PROFIBUS Diagnostic-Set II

- PROFI-TM Professional
- PROFtest II XL
- Leakage current clamp LSMZ I
- Incl. case

#### PROFIBUS Diagnostic-Set III

- INspektor® Basic-Line
- PROFI-TM Professional
- PROFtest II XL
- Leakage current clamp LSMZ I
- APKA - active programming cable
- Patch cable
- Patch cable Cross over (5m)
- Power pack
- Incl. case

Ordering details	Art. No.	Ordering details	Art. No.
PROFIBUS Diagnostic-Set II	110010009	PROFIBUS Diagnostic-Set III	110010010

Instruction in the device and further Diagnostic-Sets on request



PROFIBUS Diagnostic-Set III

## INBLOX® Modularer INspektor®

### Function

The **Modular INspektor®** of the **INBLOX®** series is a passive data collector analysing and evaluating logic and physical parameters both in PROFIBUS DP and PROFIBUS PA. Depending on the configuration it is also possible to evaluate a PROFIBUS master by which parameterization can be done via FDT/DTM. You have thus a means to monitor the field bus and the field devices in one single application. Events that can be evaluated in the analysis are

- quality characteristics through bar chart
- error telegrams
- repeat telegrams
- diagnostic messages of individual devices
- device failures
- oscilloscope function – assessment of bit form.

An integrated web server displays the network condition on every PC in form of a device-related matrix.

It is also possible to store telegram recordings of events on a memory card and display the same separately.

The Modular INspektor® consists of a head module used for connection to the existing Ethernet. It can be extended by up to five modules. By combining diagnosis and parameterization saves cost and time for commissioning and maintenance.

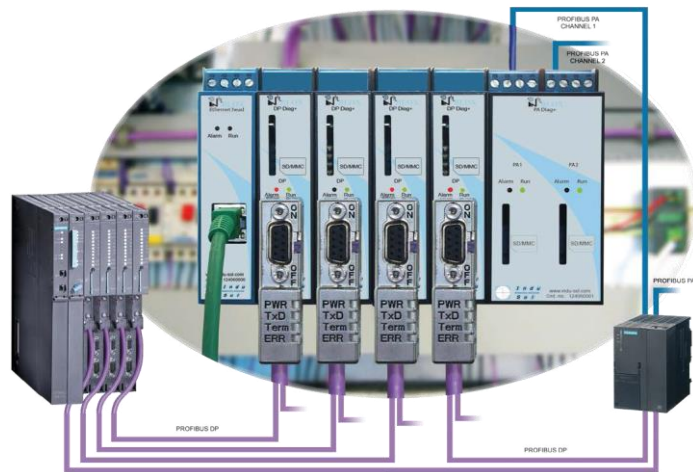

Extension DP Diag+ Rep	124060010
Extension PA Diag+	124060001
Extension DP Diag Master	124060003
Extension DP Diag Twin-Master	124060011



The Modular INspektor® with head module and extension modules

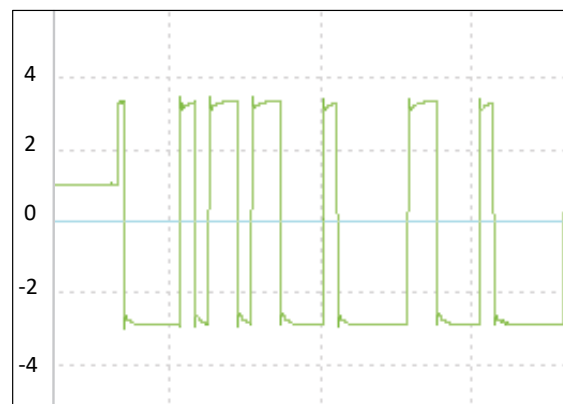

Oscilloscope function

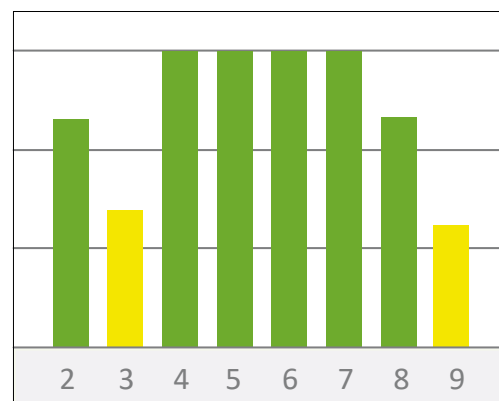

Transmission performance

## INBLOX® Modularer INspektor®

### Function / Technical data

#### Head module

The **head module** of the Modular INspektor® is used for connection to the existing Ethernet. It is thus possible to access up to five extension modules (PROFIBUS DP, PROFIBUS PA, FDT/DTM) at the same time under one IP address.

- Connection: RJ-45 (Ethernet)
- Baud rate: 10 Mbps / 100 Mbps
- Voltage supply: 24 VDC
- Installation: 35 mm DIN top-hat rail
- Dimensions (H x W x D): 86 x 22 x 110 mm
- Protective system: IP20

#### Extension DP Diag+ Rep

The **DP Diag+ Rep modul** is a decentralized PROFIBUS measurement tool with repeaterfunction developed for the temporary and permanent monitoring of the logic and physical data traffic. All major events are recognized, evaluated, buffered and displayed for every DP strand via a web interface. Every event is stored as a telegram and oscilloscope snapshot.

- Connection: RS-485 socket
- Baud rate: 9,6 kbps to 12 Mbps
- Voltage supply: via head module
- Protocols: DP, DPV1, FMS, MPI
- Installation: 35 mm DIN top-hat rail
- Dimensions (H x W x D): 86 x 22 x 110 mm
- Protective system: IP20

#### Extension PA Diag+

The **PA Diag+ modul** module can monitor, analyse and display the results of 2 PA segments in parallel. The PROFIBUS PA analyses and evaluates logic parameters as does the PROFIBUS DP. Parameters included are error telegrams and repeat telegrams but also diagnostic messages by the individual devices and device failures. chen, analysieren und zur Anzeige bringen. Im PROFIBUS PA werden logische und physikalische Parameter analysiert und bewertet. Dazu gehören neben Fehlertelegrammen und Telegrammwiederholungen auch Diagnosemeldungen der einzelnen Teilnehmer sowie Teilnehmerausfälle.

- Connection: 2 screw terminal
- Baud rate: 31,25 kbps
- Voltage supply: via head module
- Protocols: PROFIBUS PA
- Installation: 35 mm DIN top-hat rail
- Dimensions (H x W x D): 86 x 45 x 110 mm
- Protective system: IP20

#### Extension DP Diag Master / DP Diag Twin-Master

The **DP Diag Master / DP Diag Twin-Master** module enables the PROFIBUS DP to do FDT/DTM parameterization parallel to all analyses. It only needs a frame application, such as PACTware by which it is possible to parameterize and configure devices and modules as master class 2 via Ethernet. The logic diagnosis can be retrieved via

bine parameterization and logic monitoring in one module.

- Connection: RS-485 socket
- Baud rate: 9,6 kbps to 12 Mbps
- Voltage supply: via head module
- Protocols: DP, DPV1
- Installation: 35 mm DIN top-hat rail
- Dimensions (H x W x D): 86 x 22 x 110 mm
- Protective system: IP20



### Main module status information

#### Hardware details

Serial number: 1  
 MAC address: 0  
 Firmware version: v  
 Revision: e  
 Creation date/time: 2  
 Local time: 2



Ethernet Kopfmodul (E-Kopf)

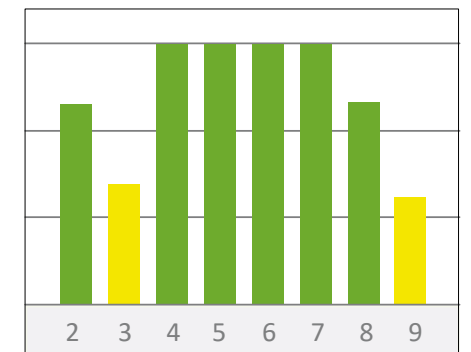

Extension DP Diag+ Rep

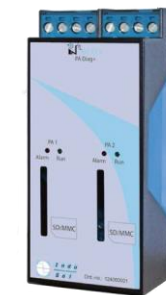

#### Node Overview



Extension PA Diag+

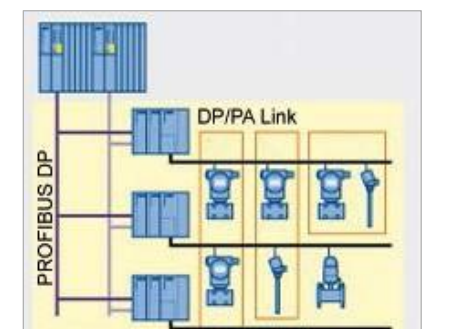

Extension DP Diag Master / DP Diag Twin-Master



## Universal tester DM-AM-Kit

### Function

The universal tester **DM-AM-Kit** is a comprehensive measuring device for the PROFIBUS PA. It is most suitable for commissioning and the quick analysis and elimination of faults.

A USB connection connects the hardware with the analysis software of a computer (PC, PG or laptop). With a clamp and a plug-in power pack it can be temporarily installed in a control cabinet for long-term monitoring. Sporadic irregularities on the bus are detected with no need of a permanent connection to the computer. Reports can be generated automatically through an assistant with all norm-related measuring results that can be read at a glance. The high-performance oscilloscope that can also be triggered with rarely occurring events, shows signal characteristics of highest accuracy.

### Measuring results - Fault alarms

- **Feldbus voltage:** The segment voltage is measured between 0 V and 35 V.
- **Earth-fault monitoring:** It measures a potential connection between Fieldbus line and shield.
- **Termination:** Over / under termination is detected and reported.
- **Communication level:** Device-related levels are measured in the range between 0 V and 2.5 V.
- **Jitter:** The jitter of a fieldbus segment has a direct impact on the communication quality of the segment concerned. The power supply quality of the field devices and all other segment components and the cable types and lengths may have an impact on the jitter.
- **Signal polarity:** It is determined for every device.
- **Noise measurement:** The noise signal can be detected for every device address in the range between 100 Hz - 140 kHz.
- **Communication error statistics:** Specific counters, e.g. for CRC and framing errors are displayed.

### Approvals

- Conformance statement: TÜV 05 ATEX 2923 X
- Type of protection, temperature class: n II 3G EEx nA [nL] IIC T4
- Guideline conformity: RL 94/9 - EG IEC 60079-15

### Technical data

- Rated voltage: 20 to 30 V
- Rated current: 70 to 30 mA
- Power loss: 0.7 W
- Electromagnetic compatibility: NE 21
- Protective system: IEC 60529
- Shock/Vibration resistance: EN 60068-2-27 / 60068-2-6
- Ambient temperature: -20 °C to 60 °C
- Storage temperature: -40 °C to 85 °C
- Relative air humidity: < 95 % non-condensing
- Shock resistance: 15 g, 11 ms
- Vibration resistance: 1 g, 10 to 150 Hz
- Dimensions (H x W x D): 114 x 35 x 85 mm

### Scope of delivery

- DM-AM kit incl. software package
- Fieldbus cable with test terminals and DM-AM fieldbus connector
- Carrying case and installation instructions
- USB cable (2 m)



DM-AM-Kit

Segment Tag: Segment2				
Segment Bus-Communication Status: <span style="color: green;">●</span>				
<b>Motherboard Properties</b>				
Label	Actual Configuration	Status	Information	
Motherboard Properties	Power Hub			
Redundancy	Redundant			
Module A	Galvanic isolated	<span style="color: green;">✔</span>	Excellent	
Module B	Galvanic isolated	<span style="color: green;">✔</span>	Excellent	
<b>Segment Data</b> <input type="checkbox"/> Ignore Secondary Bulk Power Supply when creating Snapshot				
Label	Actual Value	Min. Value	Max. Value	Status Information
Primary Voltage [V]	23.8	23.8	23.8	<span style="color: green;">✔</span> Excellent
Secondary Voltage [V]	23.8	23.8	23.8	<span style="color: green;">✔</span> Excellent
Voltage [V]	29.3	29.3	29.3	<span style="color: green;">✔</span> Excellent
Current [mA]	242.0	242.0	242.0	<span style="color: green;">✔</span> Excellent
Unbalance [%]	-2.0	-2.0	-2.0	<span style="color: green;">✔</span> Excellent
Noise [mV]	20.0	15.0	20.0	<span style="color: green;">✔</span> Excellent
Jitter [us]	0.6	0.5	0.6	<span style="color: green;">✔</span> Excellent
Min. Signal Level [mV]	626.0	620.0		<span style="color: green;">✔</span> Excellent
Max. Signal Level [mV]	630.0		630.0	<span style="color: green;">✔</span> Excellent

Segment assessment

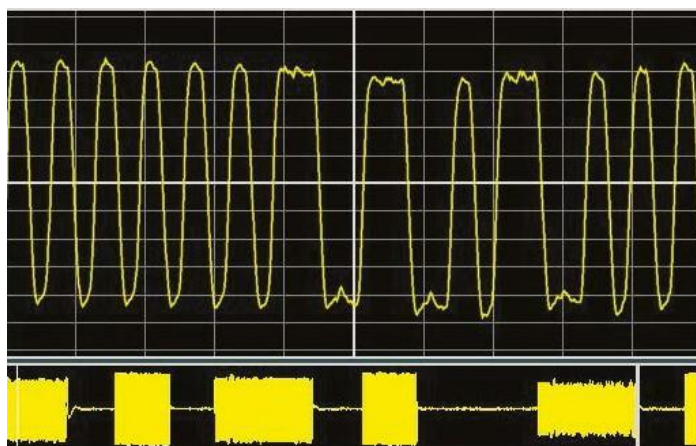

Oscilloscope function

Ordering details	Art. No.
DM-AM-Kit	110010002
DTM-FC-ADM (License)	110010003

## Universal tester PAtest

### Function

The **Universal tester PAtest** is a measuring device used to check the bus physics and the communication of the bus device in the PROFIBUS PA. The measurements are performed while the system is running. Two function keys make use every easy. The display classifies the measuring results either as „OK“ or „BAD“.

The following parameters are measured:

- the number of devices in the segment concerned
- Live-list display
- Log-on and log-out of devices
- Error and repeat telegrams
- Display of segment voltage
- Display of signal level of all devices
- Short-circuit detection between signal cores and cable shield
- Measurement of noise level average and peak

The test records of eight segments can be stored internally on the device and later transmitted to the PC via a USB interface. They can then be analysed by Microsoft® Excel.

### Bus connection

The device is supplied directly via the PROFIBUS PA and so it needs neither a battery nor an external power supply. This makes the PAtest suitable for use in explosions-hazardous zones.

### Approvals

- CE / FCC / ATEX Ex ia IIC T4
- FM US ad Canada: Class I, Div 2, ABCD, T4  
Class I, Zone 2, IIC T4  
Class I, Div 1, ABCD, T4  
Class I, Zone 0 und 1, AEx/Ex ia IIC T4

### Technical data

- Input voltage: field bus operation: 8 to 32 VDC  
USB operation: 4.1 to 5.5 VDC
- Input current: fieldbus operation: max. 10 mA  
USB operation: max. 30 mA
- Power loss: fieldbus operation: max. 320 mW (at 32 VDC)  
USB operation: max. 165 mW (at 5.5 VDC)
- Temperature range: -20 to +50 °C
- Dimensions (L x W x D): 146 x 88 x 28 mm
- Weight: 378 g
- Direct voltage measuring range: 8 to 32 ± 0.5 VDC
- Signal level measuring range: 0.12 to 2 Vss ± 10 %  
±25 mVss

### Operating systems

- Windows 2000, Windows XP, Windows Server 2003, Windows Vista, Windows 7

### Scope of delivery

- PAtest incl. MBP and USB interface
- Connecting cable incl. measurement adapters
- USB cable

Ordering details	Art. No.
PAtest	110010001



PAtest

Report 1 Segment Report			
Segment Measurements	Data	Acceptable Values	OK/BAD
Voltage	31.6V	9.0V Minimum	OK
Lowest Device Signal	1346mV	151mV Minimum	OK
Lowest Device Signal Address	2 (2H)		
Avg Fieldbus Frequency Noise	0mV	74mV Maximum	OK
Peak Fieldbus Frequency Noise	5mV	74mV Maximum	OK
Avg Low Frequency Noise	0mV	149mV Maximum	OK
Peak Low Frequency Noise	25mV	149mV Maximum	OK
Avg High Frequency Noise	0mV	149mV Maximum	OK
Peak High Frequency Noise	15mV	149mV Maximum	OK
Shield Short	No Shorts	No Shorts	OK
Most Recent Add/Drop Address	22 (16H)		
Device Add or Drop	Drop	None Added/Dropped	BAD
Number of Active Devices	2		
Device Measurements			
Device Address	Data	Acceptable Values	OK/BAD
Device Address	2 (2H)		
Signal Level	1392mV	151mV Minimum	OK
Added/Dropped	Not Added/Dropped	Not Added/Dropped	OK
Master or Slave	Master		
Retransmits	0	0	OK
Device Address	21 (15H)		
Signal Level	1458mV	151mV Minimum	OK
Added/Dropped	Added	Not Added/Dropped	WARN
Master or Slave	Slave		
Retransmits	1	0	BAD
Device Address	22 (16H)		
Signal Level	1428mV	151mV Minimum	OK
Added/Dropped	Dropped	Not Added/Dropped	BAD
Master or Slave	Slave		
Retransmits	2	0	BAD

Measurement Summary: 4 Measurements are BAD and 1 WARNING

Report

Introduction to Ethernet

**INDUSTRIAL ETHERNET**  
Solutions and services for industrial communication

With the introduction of the SINEC H1 Bus in 1985 the Ethernet-based communication found its way into automation technology. The constantly growing data flow, however, brings these systems to their limits. These limits are overcome by the development of the industrial Ethernet to PROFINET. Since the initial presentation of PROFINET in 2000 by the PROFIBUS-Nutzerorganisation e.V. (user organization) more and more existing systems have been converted and new ones are provided with it from the beginning. This standard allows a seamless connection of field level and IT. The combining of these two areas which could not be more different, makes a network analysis inevitable. Every system maintenance engineer should be able and in a position to analyse and evaluate the fieldbus under his responsibility. Early signs of problems in the Ethernet / PROFINET are, for example, error telegrams, excessive utilization or reduced bus speed.

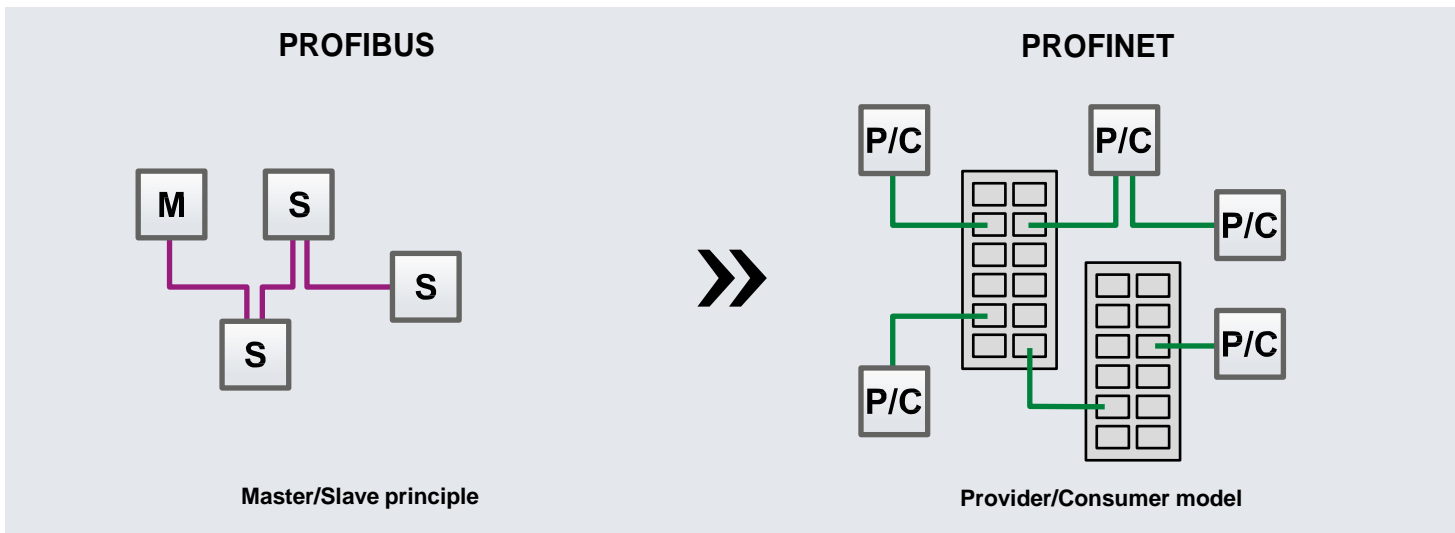

**Industrial Switch - general**

Since the Ethernet is nothing but a sequence of point-to-point connections, active components are necessary that 'interconnect' the connections. We distinguish between Hub and Switch with hubs no longer been used in industrial networks. Switches are smart hubs and forward the desired connection to reduce the network load. While passing the switch the telegrams are checked for possible errors.

**Unmanaged Switch**

Can be used as switch by plug and play without restrictions are applicable as a Switch and meet the minimum requirements described above.

**Managed Switch**

Can also be used as plug and play but have considerably more functions. The main reason, however, why to used managed switches is the fact that the monitoring of the telegram traffic, such as number of faulty telegrams/port, utilization/port done by the switch is available as statistical information for fault location or network status definition. As a basic rule: „Never trust an active network component that cannot tell you how it feels.“

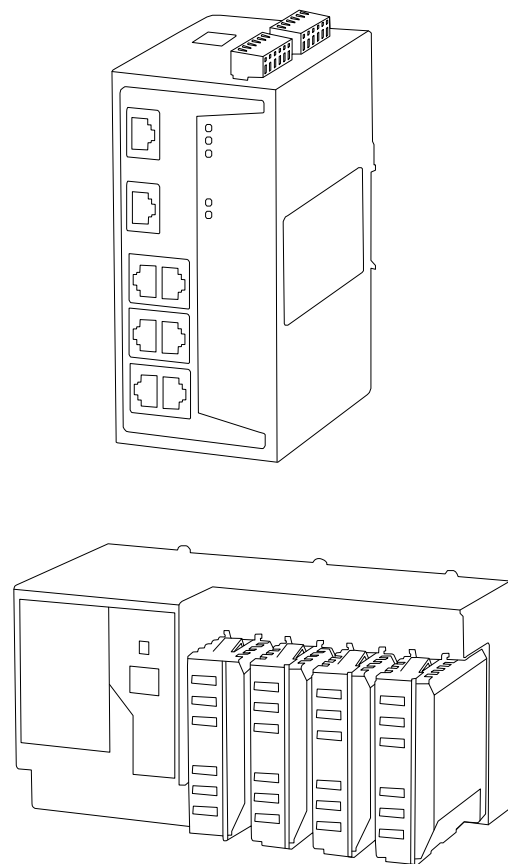

PRO ACTIVE NETWORK MANAGEMENT

„Time is money“ - Only one saying or everyday reality?

When it comes to using or transferring information, the importance of an unrestricted, reliable and stable network can hardly be expressed more appropriately than by the above saying. It is Indu-Sol's intent to explain the functioning of industrial networks. „If everything runs smoothly, the world is perfect ...!“ Unfortunately, experiences of the last few years have also taught us differently - critical areas and weak points of the network start generating much earlier but become apparent not before the network fails.

Example: When we run a network 100 MBit /FDX (full duplex), the degree of utilisation is usually 5%. Let's assume a line breaks, data exchange will automatically switch over to ‚halfduplex‘ because of the intelligence of our users. The relations in the network start changing without anyone outside noticing it.

**Kleine Ursache - große Wirkung**

To avoid collisions, now all users communicate on the CSMA / CD principle leading automatically to a higher network utilisation. Adding to that are the risk of data loss and timeout.

**Acting comes before reacting**

PROmanage® is an industrial Ethernet analyzer software providing in connection with the manageable switches a comprehensive picture of all events in the respective monitored network segment. A statistics module can record data over several hours and days.

**Network analysis**

- After setup, extension or optimisation of the network, an analysis of the actual data traffic has to be done and documented accordingly.

Our performance profile:

- Problem analysis - fault analysis
- Acceptance and certification

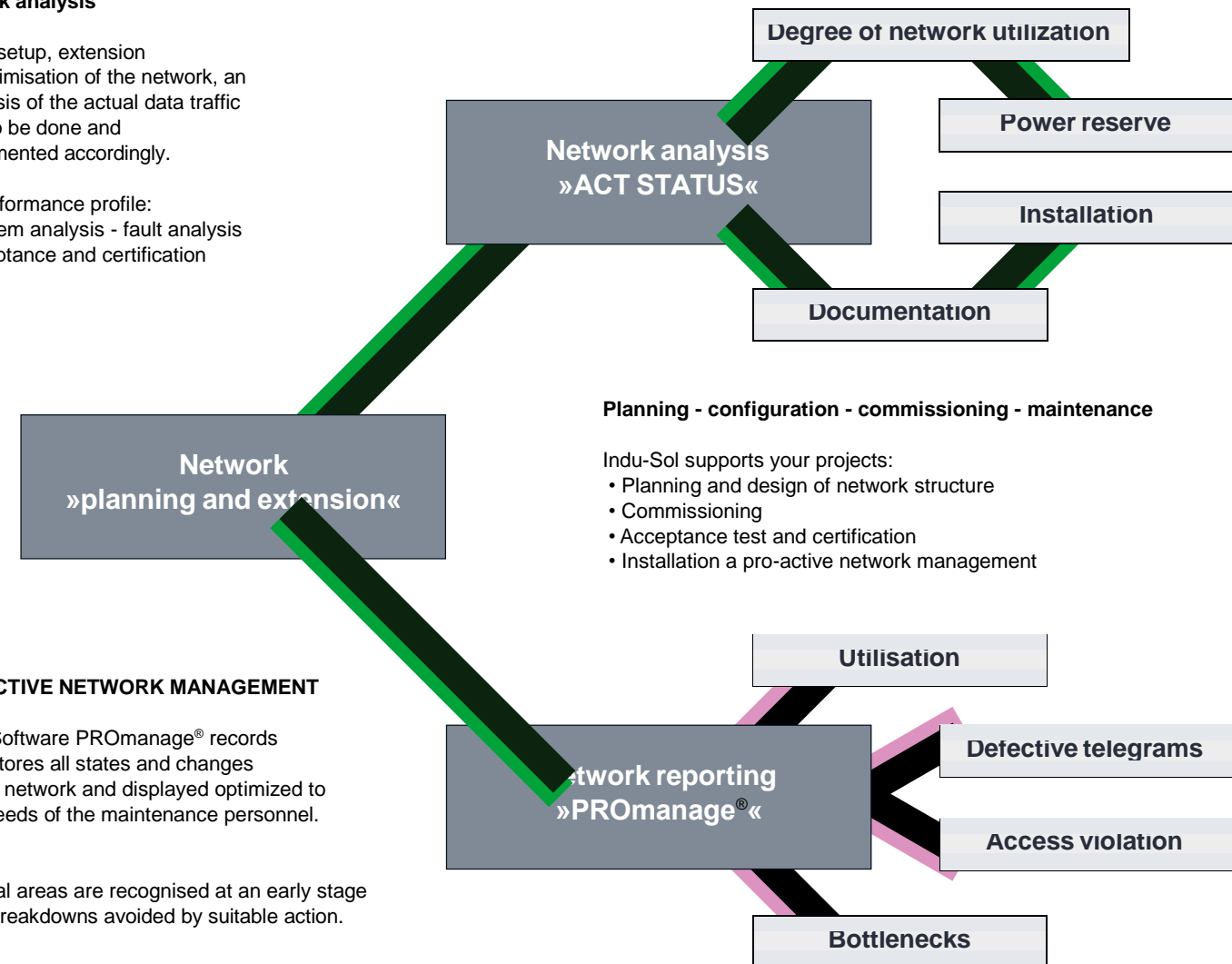

**Planning - configuration - commissioning - maintenance**

Indu-Sol supports your projects:

- Planning and design of network structure
- Commissioning
- Acceptance test and certification
- Installation a pro-active network management

**PRO ACTIVE NETWORK MANAGEMENT**

- The Software PROmanage® records and stores all states and changes in the network and displayed optimized to the needs of the maintenance personnel.
- Critical areas are recognised at an early stage and breakdowns avoided by suitable action.

**PRO ACTIVE NETWORK MAINTENANCE**  
Warning of failure!

### Topology software PROscan® Active

#### Function

**PROscan® Active** is a topology software which provides the user the opportunity to display the actual topology map on a Touch Panel and to print it out directly or to store it as a PDF file. Topology changes from scan to scan are displayed in the colors green and red. The PROscan® Active is optimized for Touch Panel usage and has big buttons available for ensuring a simple and quick operation. To display several network structures multi licences are being offered to allow the user to install the software at different installations. Therewith it is ensured that the actual topology and actual network data can be captured and displayed at all installations. PROscan® Active provides the user the following information which is of a high importance at network care and troubleshooting:

- Display of network devices in there real wiring sequence
- Extended information (for example system code, location, ...) for each SNMP network component
- Portgranular (on a port-by-port basis) location of connected terminal devices
- Line information
  - Line length
  - Power budget (POF)
- Device and topology information
  - PROFINET name
  - IP-address
  - Subnet mask
  - MAC-address
  - Gateway
  - Hardware-/ software version
  - Device type
  - Order number

The topology can be displayed in different forms of expression (hierarchy, symmetrical, circular) after users desire. Already detected network nodes are editable also afterwards.

#### Device list

MAC-address	Name	Device type	HW version	SW version
001B1B1CCA44	siemens-391f-3pndp	S7-300	V 5	V 3.2.6
0030DE0384AD	wago-750-340	WAGO-I/O-SYSTEM 75x	V 7	V 1.2.8
00A04536EDC3	phoenix-il-pn-bk	IL PN BK DI8 DO4 2TX	V 3	V 2.3.2
001B1B1E1B21	siemens-et200s-links	IM151-3	V 2	V 7.0.1
001B1B1E217A	siemens-et200s-rechts	IM151-3	V 2	V 7.0.1
000F9E053047	murr-mvk-links	MVK ProfiNet	V 1	V 3.1.0
000F9E052FCF	murr-mvk-rechts	MVK ProfiNet	V 1	V 3.1.0
001677008FA1	pn-asi-gw	AS-i	V 2	V 2.0.0
001B1B24DA80	siemens-et200m	IM153-4	V 2	V 4.0.0
001B1B565176	im151-3pn-highfeature	IM151-3	V 8	V 7.0.5
00A045012615	fl-mmhs-reihe-1	FL SWITCH SMCS 8TX-PN	V 1280	V 3.80.0
001B1B3483A6	scalance-x202-2p-irt	SCALANCE X-200	V 5	V 5.0.22
001B1B3AEC7E	scalance-x208-reihe5	SCALANCE X-200	V 6	V 4.4.3
0011FC063700	harting-fts3100-a-links	FTS3100-A	V 256	V 2.2.2
0011FC063460	harting-fts3100-a-rechts	FTS3100-A	V 256	V 2.2.2
00A0456820F9	phoenix-smcs	FL SWITCH SMCS 8TX-PN	V 1280	V 3.80.0
0080636654B0	octopus-8m	Hirschmann OCTOPUS	V 33280	V 4.2.3

Ordering details	Art. No.
<b>PROscan® Active</b> 1er License	<b>117000014</b>
<b>PROscan Actie</b> 5er License	<b>117000018</b>
<b>PROscan® Active</b> 25er License	<b>117000019</b>

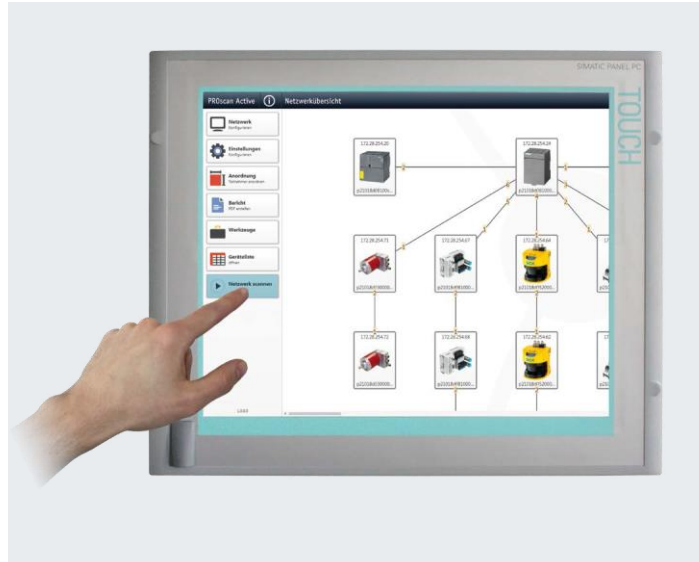

#### Topology display

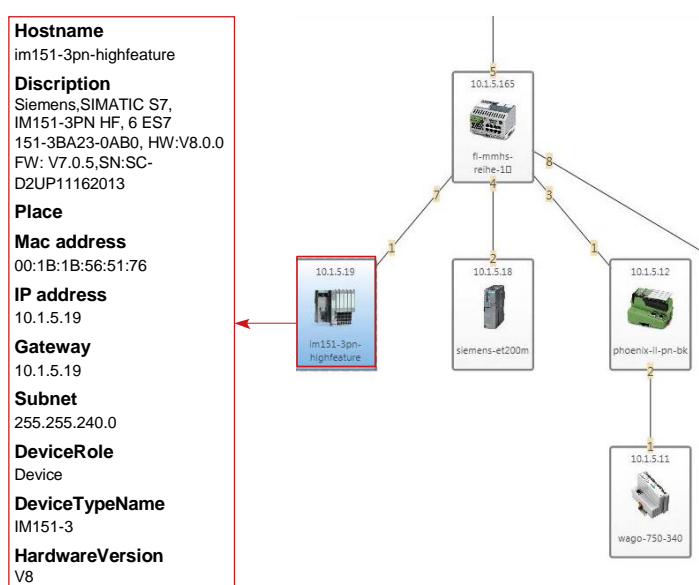

#### Direct device information

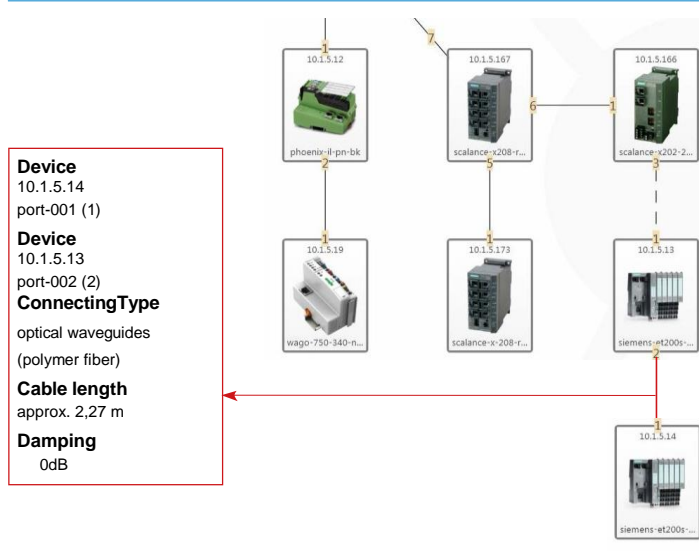

**Device**  
10.1.5.14  
port-001 (1)

**Device**  
10.1.5.13  
port-002 (2)

**ConnectingType**  
optical waveguides  
(polymer fiber)

**Cable length**  
approx. 2,27 m

**Damping**  
0dB

#### Direct line information

### Logic tester PROInet-INSpektor®

#### Function

Besides its function as a passive data collector for PROFINET networks the **PROInet-INSpektor®** is also a fully adequate measuring device. An integrated TAP converts the PN-INSpektor® to a smart measuring point for online analysis. It connected with the bus by looping it in the connection from the control system to the first downstream device. With the help of an isolated contact is an automatic alarm possible. The PN-INSpektor® provides information about:

- Utilization rate
- Speed
- Data throughput
- Telegramm gabs
- Telegramm jitter

This information reflects the current condition of the communication quality in the network concerned.

#### Technical data

- Voltage supply: 24 VDC +/-20 %, typ. < 1 A
- PROFINET:
  - Protocols: RT, CBA
  - Connection: RJ45
  - Baud rate: 10 / 100 Mbps
- Ethernet
  - Baud rate: 10 / 100 Mbps
  - Connection: RJ45
  - MDI/MDIX
- Mirror Port
  - Baud rate: 10 / 100 / 1000 Mbps
  - Connection: RJ45
  - MDI/MDIX

#### General data

- Installation: 35 mm DIN top-hat rail
- Dimensions (H x W x D): 131 x 110 x 111 mm
- Protective system: IP20
- Ambient temperature: +5 °C to +70 °C
- Storage temperature: -20 °C to +70 °C

Ordering details	Art. No.
<b>PROInet-INSpektor® Basic Line - basic device</b>	<b>124030000</b>
<b>Extension Comfort-Line</b>	<b>124030002</b>
<b>Accessories</b>	
<b>Ethernet Patchkabel</b>	<b>124080003</b>
<b>Power pack 2,5 A</b>	<b>130010004</b>



#### PROInet-INSpektor®

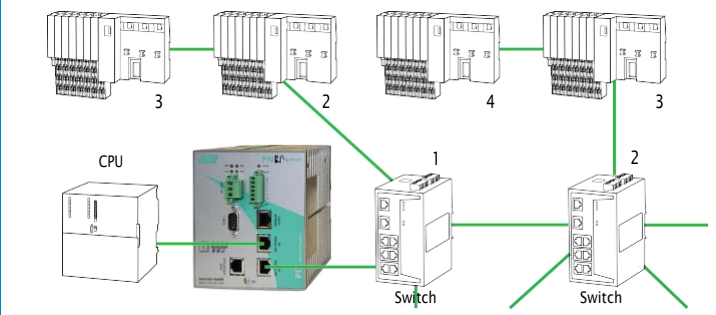

#### PROInet-INSpektor® „His place in the network“

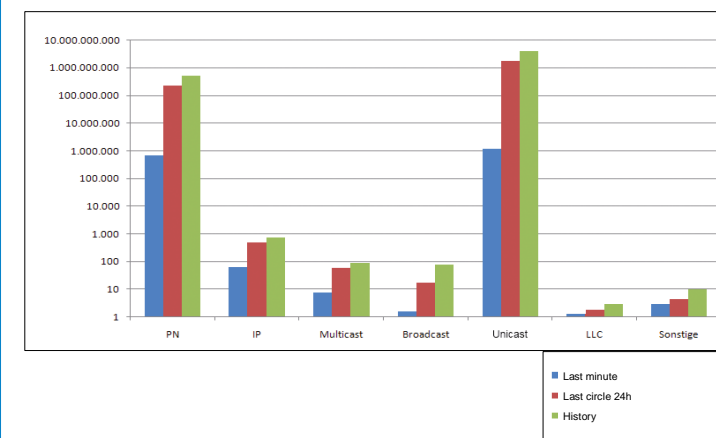

#### Network statistics

### Line tester ETHERtest V4

#### General

The line tester ETHERtest V4 is an indispensable measuring device to check, document and certify the network infrastructure for Ethernet, PROFINET, EtherCAT or InterBus\*. It is easy to use and menu-navigated (13 languages available).

\* continuity test only

#### Function

The measuring device is capable of evaluating all necessary measurements for the certification of copper networks up to Category 7 (900 MHz), such as line length, attenuation, crosstalk, resistance, delay, shield, wiring diagrams. The Cat 6 measurement commonly used in practice is carried out within 9 seconds. It is also possible to test optical fibre lines by using an additional adapter. Both multimode (850nm/1300nm) and single mode (1,310nm/1,550nm) can be measured. All measurements are displayed graphically. Type and place of errors can be identified by the locator exactly to the decimeter. A certification protocol is issued for certification. To carry out the line test, it is necessary to have a remote station.

#### Device Interfaces

- Line test RJ45 port (optical fiber or M12 available as accessory equipment)
- USB interface to transmit the measuring results to the PC
- SD card to extend the number of measuring results
- 3,5 mm stereo interface for Talkset
- Battery charger interface

#### Memory

- Internal flash memory for 250 graphic Cat 6 test results
- External SD card (not included in the scope of supply) for up to 2,000 graphic Cat 6 test results per 128 MB

#### Power supply

- Removable Li-Ion battery
- approx. 12 hours of battery life

#### Scope of delivery

- Main unit (RJ45)
- Remote device (RJ45)
- Carrying case
- Permanent link adapters (2x)
- Channel adapter (2x)

Ordering details	Art. No.
ETHERtest V4 standard	112010003
ETHERtest V4 350 MHz (extendable for optical fibre)	112010001
ETHERtest V4 900 MHz (extendable for optical fibre)	112010002
<b>Accessories</b>	
Optical fibre single mode adapter	112020000
LWL-Multimode Adapter	112020001
M12 Adapter	112020004



Line tester ETHERtest V4

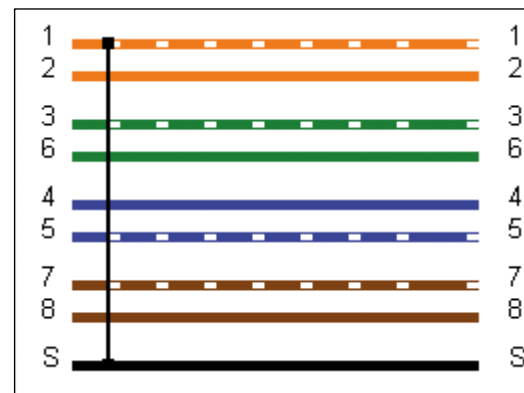

#### Wiring plan

The wiring plan shows whether the individual cores were correctly connected, so that the specific lay of the pairs in the cable is maintained.

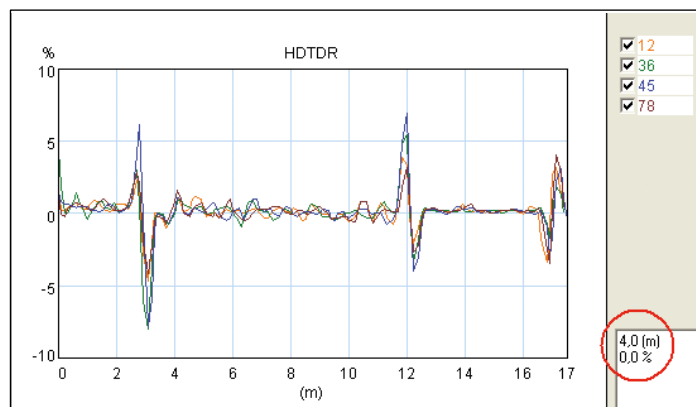

#### Fault order

This figure shows at which distance one core or a pair gets too high an attenuation.

### Line tester ETHERtest Light

#### Function

The ETHERtest Light is an indispensable tool for all installing Ethernet or dealing with troubleshooting. Unlike a standard continuity testers it measures additionally the total length of the cable and locates installation problems exactly to the meter thus making troubleshooting much easier. A certification according to Class or CAT and a report printout are not possible.

#### Technical data

- Area: 150m (500 ft)
- Accuracy: +-5%
- Cable types: UTP, STP, FTP, SSTP
- Service location: Telephon, 10BaseT, 100BaseTX, Token Ring
- Storage temperatur: -20 to +70°C
- Operating temperature: 5 to 95% r. F. non-condensing

#### Main Unit

- Weight: 350 g
- Dimensions (H x W x D): 165 x 90 x 37 mm

#### Remote-Gerät

- Weight: 40 g
- Dimensions (H x W x D): 65 x 52 x 25 mm
- Wiring types: TIA 568A/B, UNSOC & ISDN, ISO11801, EN50137
- Display of the main unit: 128 x 64 Pixel LCD-Grafikdisplay
- Battery life: standby operation > 4,000 h, permanent testing > 7.5 h

#### Features / information

- Indicated errors: short circuit pair, open circuit wire, short between pairs, split/cross pairs, pair reversals, shield continuity
- Error location: near end, remote end or distance (if mid way)
- Measurement of total line length
- Test inhibit: inhibits testing in the presence of live voltages
- Tone generator: oscillating tone 810 Hz - 1110 Hz
- Battery indicator: 0 to 100% bar graph
- Error display: all faults and settings displayed as text and graphically
- Display backlight: electroluminescent
- Remote display: green/red LED
- Languages: Englisch (USA and UK), German, French, Spanish, Italian
- Auto-Off: after 3 minutes

#### Norms / Directives

- Protection: IEC61010-1
- EMC: EN61326-1
- CE: Compliance with EU Directives
- ESE: EN61000-4-2
- EM: EN61000-4-3
- Burst: EN61000-4-4
- Conducted RF: EN61000-4-6

Ordering details	Art. No.
ETHERtest Light	112010000



Line tester ETHERtest Light

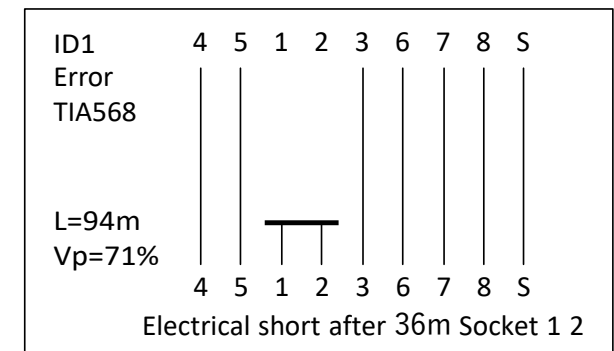

#### Error diagnosis with „short circuit“ used an example

Pr.	4-5	64m
Pr.	1-2	64m
Pr.	3-6	—
Pr.	7-8	64m

TIA568 UTP Vp=71%

#### Example Cable length measurement

**PROFINET Diagnostic-Set**

**PROFINET Diagnostic-Set III**

- PROFInet-INspektor Basic-Line
- PROscan® Active
- ETHERtest Light
- leakage current clamp EmCheck® LSMZ I
- Power pack
- 2x Patch cable
- USB Gigabit network card adapter
- Incl. case

**PROFINET Diagnostic-Set IV**

- PROFInet-INspektor Basic-Line
- PROscan® Active
- ETHERtest V4
- leakage current clamp EmCheck® LSMZ I
- Power pack
- 2x Patch cable
- USB Gigabit network card adapter
- Incl. case

Ordering details	Art. No.
PROFINET Diagnostic-Set III	114010005

Ordering details	Art. No.
PROFINET Diagnostic-Set IV	114010006



Instruction in the device and further Diagnostic-Sets on request

PROFINET Diagnostic-Set III

**Active measuring point ETMA**

**Function**

The **ETMA measuring point** serves for feedback-free telegram recording in Ethernet / PROFINET networks under production conditions. A permanent installation of the measuring point in the network connection between the automation equipment (SPC) and the first switch is recommended because typically the greater part of the communication converges in this connection. Two RJ45 sockets are available at the unit. The ETMA should be connected to the analysis tool (PN-INspektor®) with two network cables (patch cable). By using the PN-INspektor® it is possible to read out and record in parallel the full duplex data traffic without telegram loss. To analyse and evaluate the measuring results, the telegrams from both communication directions can be superimposed in terms of time. Error telegrams are not rejected by the ETMA but forwarded.

**Task: Telegram recording while the system is running**

**Normal recording by port mirroring**

- Advantages:
- no additional hardware required (no ETMA)
- Disadvantages:
- time-consuming creation of mirror port at switch
  - high load of switch by mirror port
  - package losses at high data rates
  - bidirectional mirror port urgently required
  - defective telegrams are not mirrored

**Recording through ETMA**

- Advantages:
- no costly provision of measuring point
- Disadvantages:
- unconditionally bidirectional up to 100 Mbps
  - additional hardware
  - expert analyzer required

**Technical data**

- Installation: 35 mm DIN top-hat rail
- Dimensions (H x W x D): 110 x 30 x 85 mm
- Power supply: external 24 VDC
- Connector: RJ45
- Delay time: less than 1 Bps at 100 Mbps
- Cable: Cat 5 / Cat 5E, max. 100 m
- Operating temperature: -15 °C to 75 °C
- Storage temperature: 0 °C to 50 °C
- Air humidity: 10 to 90 %, non-condensing
- Approvals: CE, FCC class B

**Information to connecting**

For the connection of the PROFInet-INspektor® via an ETMA (TAP) it must be made sure that one of the two lines between the ETMA and the INspektor® is a cable.

Ordering details	Art. No.
ETMA (for top-hat rail)	112040001



Active measuring point ETMA

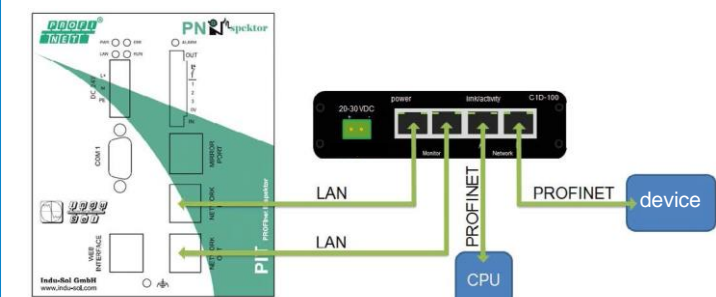

Example of connection for PROFInet-INspektor®

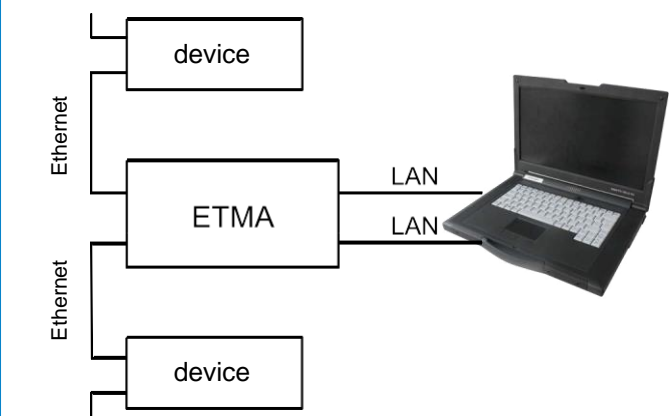

Analysis with Laptop

### Quality tester ASi View

#### Function

The **ASi view** is a tool for determining the physical and logic communication quality of the data exchange in ASi networks. The measurement is performed online while the system is running. The measuring and test results are displayed through a software on your PC. An USB interface is used for the connection to the PC.

#### Automatic mode

The Automatic mode measures the communication parameters and gives general assessment of the quality at site. All that is needed is to connect the adapter cable to the network to be tested and connect a laptop via an USB cable, start the control program and store the data after a certain collection time. If problems are signalled, the information issued by the program in plain text should be followed. No special knowledge of AS interface is required for the automatic mode.

#### Expert mode

The „Expert“ mode as a second mode is designed for a detailed analysis of any problem that may arise in the AS interface network. This mode requires specific knowledge of the AS interface and the communication principles applied. It may be used both at site by qualified service personnel and at the lab by product developers and enables an in-depth analysis of the communication events in the network.

#### Technical data

- DC voltage supply via USB interface from the PC
- max. Power: 420 mA
- Voltage: max. 40 Vss
- Frequency: AS-Interface frequency spectrum
- Sampling rate: 2,5MHz
- Measuring time for a data block: 50ms

#### Ambient conditions

- Protective system: IP20
- Temperature range: 0 to 45 °C
- Relative humidity: max. 80%, non-condensing

#### Scope of delivery

- ASi View
- Oszi M12 adapter
- USB cable (2 m)
- CD containing software and user manual
- ASiMA

#### Ordering details

ASi View

#### Art. No.

120010001



ASi View



Evaluation of the signal quality for all devices



Evaluation of the signal quality for one device „eye pattern“

Standard- and A-Slaves:			B-Slaves:		
Total	Master	Slave	Total	Master	Slave
1: 1000	0	0	17: 0	0	0
2: 1000	0	0	18: 0	0	0
3: 1000	0	0	19: 0	0	0
4: 1000	0	0	20: 0	0	0
5: 1000	0	0	21: 0	0	0
6: 1000	0	0	22: 0	0	0
7: 0	0	0	23: 0	0	0
8: 0	0	0	24: 0	0	0
9: 0	0	0	25: 0	0	0
10: 0	0	0	26: 0	0	0

Telegram analysis including error statistics per device

### Decentralized data logger ASi-INspektor®

#### Function

The **ASi-INspektor®** is a passive data logger that analyses the telegram traffic of ASi networks for events, such as

- error telegrams,
- repeat telegrams,
- package error
- device diagnosis and
- device failures.

This information reflects the current status of the communication quality in ASi networks. All collected network data can be retrieved via Ethernet using an integrated web interface.

#### Technical data

- Voltage supply: 24 VDC
- ASi-Bus - Connection: terminal
- Ethernet - Baud rate: 100BASETX / 10 Mbps
- Ethernet - Connection: RJ45

#### General data

- Installation: 35 mm DIN top-hat rail
- Dimensions (H x B x T): 105 x 23 x 111 mm ASi-INspektor®
- Dimensions (H x B x T): 105 x 23 x 111 mm ASi-INspektor with Switch and Pure-box
- Industrial protection: IP20
- Ambient temperature: 0 °C to 55 °C
- Storage temperature: -25 °C to 85 °C

#### Scope of delivery StarterKIT

- ASi-INspektor®
- M12 cable to ASi-BUS
- ASiMA (ASi-Messadapter M12)
- Patch cable
- Switch for ASi-INspektor®
- Pure-box to provide the ASi-INspektor® web interface
- User manual

#### Ordering details

ASi-INspektor® 124040000

#### Accessories

Active measuring point ASiMA IP67 120040000

M12 cable 120010003

Ethernet patch cable 124080003

Ethernet patch cable cross over 124080002

#### StarterKIT

StarterKIT ASi-INspektor® 124040001



ASi-INspektor®

possible conditions						
3	4	5	6	7	8	9
Device 3 Location 3	Device 4 Location 4	Device 5 Location 5	Device 6 Location 6	Device 7 Location 7	Device 8 Location 8	Device 9 Location 9
Device 13 Location 13	Device 14 Location 14	Device 15 Location 15	Device 16 Location 16	Device 17 Location 17	Device 18 Location 18	Device 19 Location 19
Device 23 Location 23	Device 24 Location 24	Device 25 Location 25	Device 26 Location 26	Device 27 Location 27	Device 28 Location 28	Device 29 Location 29

Device list ASi in PROmanage®

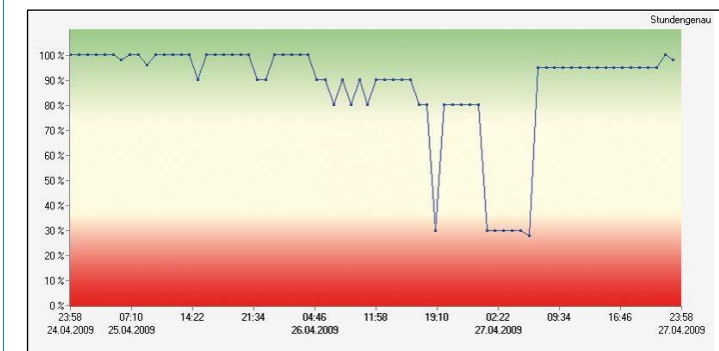

Network status ASI in PROmanage®

## Quality tester CANBUSview XL III

### Function

The **CANBUSview XL** is a tool for determining the physical and logic communication quality of the data exchange in CAN networks. The measurement is performed online while the system is running. By means of an adapter the hardware is plugged feedback-free onto the CAN. The measuring and test results are displayed through a software on your PC. A standardized USB interface is used for the connection to the PC. We recommend to use the two ends of each segment/master system as measuring location in the CAN network. For this purpose suitable measuring points have to be provided.

### The measuring principle

### CAN protocols

With the CANBUSview XL various CAN protocols can be analysed and evaluated in terms of quality, such as CAN, CANopen, SafetyBUS p and DeviceNet. Prior to the measurement the user is requested to select the relevant CAN protocol.

### Physical quality determination

#### Signal quality

The CAN bus works with a differential voltage signal transmitting the logic telegram content to the lines CAN-H and CAN-L. The amount of the voltage differential and the form of these signals are a measure of the physical transmission quality and signal quality. Every bit undergoes a 64-fold scan. Major parameters used for the analysis are edge steepness, signal-to-noise voltage ratio and ripple of the CAN signal. The measuring result is recorded over the time and as Q-value in the form of a bar chart. This measuring technique allows an easy and quick determination of the actual quality of the data communication.

#### Wiring test

To ensure a correct bus wiring, the CANBUSview XL has an integrated wiring test. Any line short-circuits, line break, missing or additional terminating resistor can be detected and eliminated. In addition the loop resistances of the CAN line and the CAN current supply line and the total line length are determined.

### Logic quality determination

Parallel to the physical transfer quality determination the CANBUSview XL checks the telegram traffic for defective telegrams, missing acknowledgements and overload of bus devices as well as the general bus capacity utilization. The online trigger is used to analyse the communication quality over several days / weeks. This helps to detect sporadic communication faults and allocate the same to a certain period of time. The online trigger is capable of analysing physical and logic faults.

Ordering details	Art. No.
CANBUSview XL III für CAN	119010001
Extension CANopen / SafetyBUS p	119010002
Extension DeviceNet	119010003
Extension SAE J1939	119010004
Extension CANopen Monitor	119010005



CANBUSview XL III



Bar chart

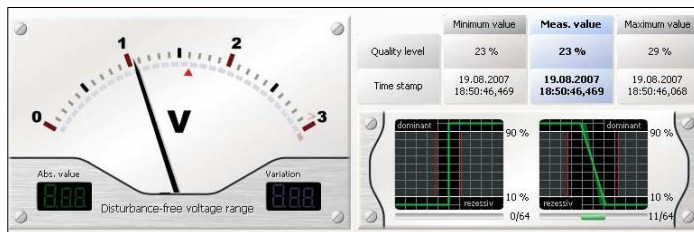

Individual measurement

Connector	Pin	Signal	Error	Designation
 Male	7	CAN_H		Line-break test: An interrupt at CAN_H was found.
	2	CAN_L		
	5	CAN_SHLD	Please solve the problem.	
	9	CAN_V+		
	6	CAN_V-		

Wiring test

## Decentralized data logger CB-INspektor®

### Function

The **CB-INspektor®** is a passive data logger for the CAN fieldbus. The traffic light colours (green, yellow, red) highlight the status of the device and provide detailed information on faults, such as

- error telegrams,
- device diagnoses,
- network utilization and
- device failures.

All network data logged are totalled per device and stored and can be retrieved either via the web-based user interface of the CB-INspektor® or the Ethernet using the standardized SNMP query protocol and the management software PROmanage®. Because of the large variety of implemented CAN protocols three different CB-INspektors® are available to the user.

### Technical data

- Voltage supply: 24 VDC +/-20 %, typ. 0.3 A
- CAN:
  - Protocols: CAN, CANopen, DeviceNet, SafetyBUS p
  - Connection: 9-pole sub-D
  - Baud rate: 9.6 kbps - 1 Mbps
- Ethernet
  - Baud rate: 100 Mbps / 10 Mbps
  - Connection: RJ45

### General data

- Montage: 35 mm DIN top-hat rail
- Dimensions (H x W x D): 131 x 110 x 111 mm
- Protective system: IP20
- Ambient temperature: 5 °C to 70 °C
- Storage temperature: -20 °C to 70 °C



CB-INspektor®

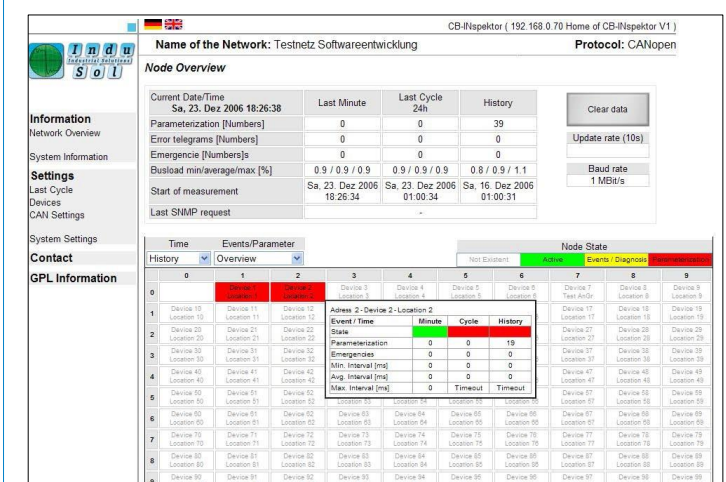

### Live List

Graphic display of logic quality parameters in network, early warning alarm when thresholds are exceeded.

Ordering details	Art. No.
CB-INspektor® CAN / CANopen	124050004
CB-INspektor® DeviceNet	124050005
CB-INspektor® SafetyBUS p	124050006
<b>Accessories</b>	
Ethernet patch cable cross over	124080002
Power pack 2,5 A	130010004

## Leakage current clamp EmCheck® LSMZ I

### Function

The **leakage current clamp EmCheck LSMZ I** is specially designed to measure leakage and shield currents in the frequency ranges of 50/60 Hz and 5 Hz to 1 kHz. It is characterized by a large opening (2.8 cm) for cable to lead through, so that a comfortable measurement is also possible in unfavorable installation situations. The measuring tool features a broad measuring range from 30 µA to 100 A with the lower range being of particular interest. Through the holding-function it is possible to perform permanent measurements, such as maximum current. Shield currents are a problem for high frequent field bus cables to originate from a frequently missing or bad potential equalisation as well as a magnetic interference by a power supply cable.

### Advantages

- Illuminated display
- Shield current measurement
- Measuring range up to 100 A
- Wide opening of shield current clamp (up to 2.8 cm)
- Holding functions allow a permanent measurement at maximum current
- Frequency changeover (50/60 Hz - 5 Hz ... 1 kHz)
- Shielded sensor

### Tool information

- Manual selection of measuring range
- Integrated data storage
- Auto power-off (Battery life indicator)

### Measuring range

- AC current: 30 µA to 100 A  
Tolerance: 1.2 % ± 5 Digit (50 to 60 Hz)  
2.5 % ± 5 Digit (60 to 500 Hz)  
3.5 % ± 10 Digit (500 Hz to 3 kHz)
- Voltage AC: 0,1 to 600 V  
Tolerance: 1 % ± 5 Digit (50 to 60 Hz)  
1.2 % ± 1 Digit (60 to 500 Hz)  
2.5 % ± 5 Digit (500 Hz to 3 kHz)
- Input impedance: 1 MOhm
- Resistance: 0.1 Ohm to 1 kOhm  
Tolerance: 1 % ± 3 Digit
- Continuity: < 35 Ohm

### Frequency range

- Current / voltage AC: 5 Hz to 1 kHz; 50/60 Hz
- Frequency measurement: 50 Hz to 3 kHz

### Technical Data

- Safety in accordance with: IEC61010-1 release 95  
IEC61010-2-032 release 93
- Isolation class: Class III
- Overvoltage category: CAT III 600 V
- Pollution degree: 2
- Display: 4 digit LCD; 9999 Digits
- Clamp opening: ø 28 mm
- Power supply: 2 x 1.5 V; AAA or LR3
- Strong immunity to spurious currents: 70 dB
- Dimensions (L x H x W): 218 x 64 x 30 mm
- Weight: 280 g incl batteries



Leakage current clamp EmCheck® LSMZ I

Ordering details	Art. No.
EmCheck® LSMZ I	122010005
Set of measuring clamps (MWMZ I and LSMZ I)	122010006

## Mesh resistance measuring clamp EmCheck® MWMZ I

### Applications

The **EmCheck® MWMZ I** is an essential measuring instrument for anybody for whom intuitive statements on the quality of the installed shield and earth measures are not enough.

The measuring clamp can be used for the following:

Measuring shield loop resistances of bus cables or measuring system cables, for example. Normal good shield loop resistances should be in a range up to approx. 0.6 Ohm. An adequately low shield loop resistance is a basic requirement for a good shield effect.

Measuring the PE cables routed pursuant to DIN EN 50310 to achieved good equipotential bonding. Normal good PE loop resistances should be in a range up to approx. 0.3 Ohm. An adequately low PE loop resistance is a basic requirement for ensuring good signal reference potential.

Measuring the quality of the shield on the motor cable of frequency-controlled motors and the resistances in the reverse current path.

### Measurement results

The probe consists of two coils. The first coil induces a voltage of a defined level and with a defined frequency of 2.2 kHz. The second coil measures the current induced by coil one in a frequency range of 2.2 kHz. The ration of these two values can then be used to find and display the alternating current resistance (impedance). The measurement is made without interruption and can also be carried out on conductors which already carry current during normal operation. If the operating currents are in the frequency range of the probe and thus falsify the measurement result, the probe will indicate a "noise" warning.

### Technical data

- Interference emitter: LF EN 61326-1: 2006
- Interference immunity: LF EN 61326-1: 2006
- Max. overload capacity: Maximum continuous current  
100 A (50/60 Hz), briefly (< 5 s)  
200 A (50/60 Hz)
- Housing: Polycarbonate
- Dimensions: 55 x 100 x 240 mm
- Max. ø of the loop: 32 mm
- Weight: 1 kg
- Seal: IP30, Group III device pursuant to EN 60529, 1992 IK04, pursuant to EN 50102, 1995
- Category: 300 V CAT II/soiling level 2 and 600 V CAT II
- Power supply: 9 V alkali battery  
Type IEC 6F22 or equivalent
- Current consumption: Around 40 mA
- Measuring frequency: 2.2 kHz

### Measuring characteristics

- Room temperature: 23°C
- Relative humidity: 50% r.h. ± 10%
- Battery voltage: 8 V ± 0.2 V
- External magnetic field: < 40 A/m
- External electrical field: < 1 V/m
- Measured current/sinusoidal frequency: 50 Hz
- Distortion level: < 0.5 %



EmCheck® MWMZ I

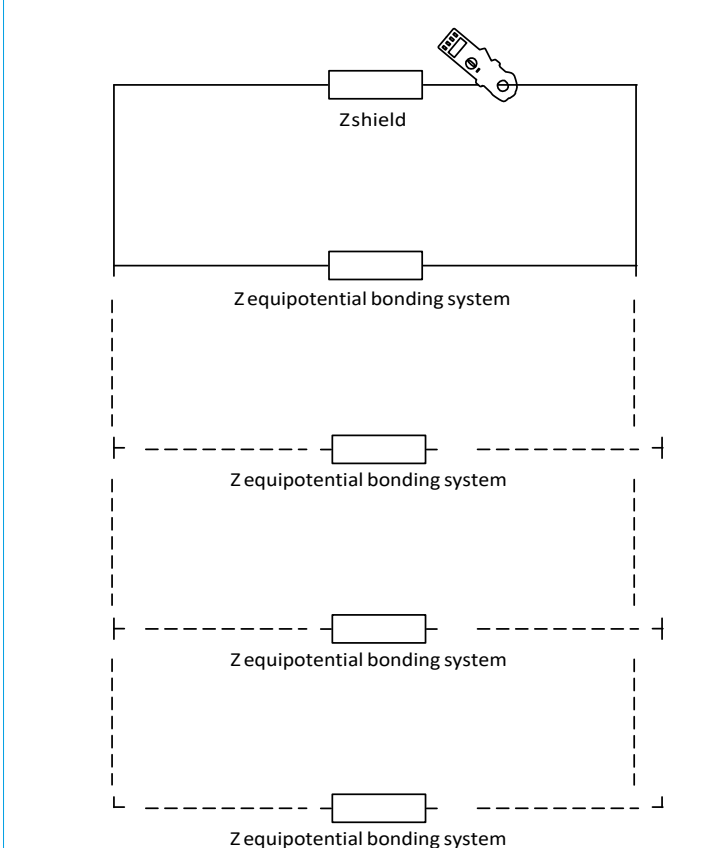

Specimen shield resistance measurement

Ordering details	Art. No.
EmCheck® MWMZ I	122010003
Set of measuring clamps (MWMZ I and LSMZ I)	122010006



### Special-purpose measuring and programming adapter

#### Function

The M12 measuring and programming adapter is used for the connection of an active programming cable to a M M12 interface, e.g. PBMX.

The M12 Y measuring adapter is used to connect the measuring devices PROFtest II and PROFI-TM Professional. The measuring adapter PB-DSUB-1 is only used for online measurement with PROFI-TM Professional. It is not suitable for master simulator or topology scan.

#### Electrical parameters

- Baud rate: 9.6 kbps to 12 Mbps
- Rated voltage: 24 VDC

#### Ambient conditions

- Temperature range: -20 °C to +40 °C
- Protective system: IP20

#### Pin assignment

##### M12 Y measuring adapter

- Pin 1: not assigned
- Pin 2: A-Line
- Pin 3: not assigned
- Pin 4: B-Line
- Pin 5: shield

##### M12 measuring and programming adapter

- Pin 1: 5 V
- Pin 2: A-line
- Pin 3: GND
- Pin 4: B-line
- Pin 5: Shield

##### Measuring adapter B-DSUB-1 (for critical plant)

- Pin 1: not assigned
- Pin 2: not assigned
- Pin 3: B-Line (red)
- Pin 4: RTS direction control
- Pin 5: GND
- Pin 6: 5 V
- Pin 7: not assigned
- Pin 8: A-Line (green)
- Pin 9: not assigned



M12 Y-measuring adapter



Measuring and programming adapter straight



Measuring and programming adapter angled



Measuring adapter for critical plant

#### Ordering details

Y-Measuring adapter M12	110020018
Measuring- and programming adapter straight	110020019
Measuring- and programming adapter angled	110020020
Measuring adapter PB-DSUB-1	110020013

#### Ordering details

PROFtest II measuring adapter K348 Y-cable	110020006
PROFtest II measuring adapter K349 cable	110020005
PROFtest II connecting cable K415	110020008
PROFtest II measuring adapter K486 spur line	110020007

#### Art. No.

110020006
110020005
110020008
110020007

### PROFtest II XL measuring adapter / connecting cable

#### Function

The PROFtest II measuring adapter K348 / K349 / K415 and K486 is used for the connection of the measuring devices PROFtest II and PROFview XL to the PROFIBUS.

With the measuring adapter the 5 V come from a device.

#### Electrical parameters

- Baud rate: 9,6 kbps to 12 MBps
- Rated voltage: 24 VDC

#### Ambient conditions

- Temperature range: -20 °C to +40 °C
- Protective system: IP20

#### Pin assignment

- Pin 1: not assigned
- Pin 2: not assigned
- Pin 3: B-Line (red)
- Pin 4: not assigned
- Pin 5: GND
- Pin 6: 5V
- Pin 7: not assigned
- Pin 8: A-Line (green)
- Pin 9: not assigned



PROFtest II measuring adapter K348



PROFtest II measuring adapter K349



PROFtest II connecting cable K415



PROFtest II measuring adapter K486

### Mobile power supply unit MoSt

#### Function

The **mobile power supply unit MoSt** is a very practical accessories for measuring and test equipment, such as PROFview XL®. In a rough industrial environment the necessity of a 230 V supply may create a problem since not every application is arranged in a cubicle or in the vicinity of the same. Extension cords and cable drums are a way out but finally become an obstacle. The mobile 24 VDC battery power supply MoSt is extremely versatile and its high degree of protection, IP64, makes it ideal for industrial uses. A purpose-tailored adaptor foot station with electronic internal switch and a commercially available NiCd battery with charger form the entire MoSt package. Depending on the need either the whole package or individual components may be supplied. On request the 24 VDC plug connector is also available in different types.

#### Electrical parameters

- Capacity: 2 Ah
- Determined operating time at 0.2 A load: approx. 10 h
- Visual operation display

green -  $U_b = 24\text{ V} - 20\text{ V}$   
 yellow -  $U_b = 20\text{ V} - 18\text{ V}$   
 red -  $U_a < 18\text{ V}$

#### Design

- Dimensions (H x W x D): battery: 135 x 130 x 80 mm  
 battery charger: 80 x 130 x 75 mm  
 adaptor station: 85 x 155 x 10 mm
- Weight: battery: 1100 g  
 battery charger: 1300 g  
 adaptor station: 300 g
- Case: plastic material



Mobile power supply MoSt



Battery charger

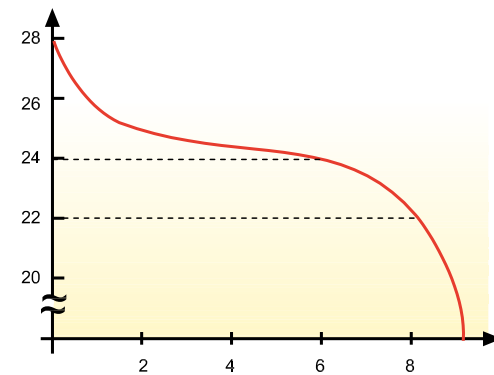

Performance diagram

Ordering details	Art. No.
MoSt - Set	110020023
comprising:	
Battery 24 V to 2 Ah	110020024
Bag	110020026
Adapter station	110020027
Battery charger	110020025

### Fast Connect Stripping Tool

#### Function

The **Fast Connect Stripping Tool** is used for PROFIBUS / Ethernet cable stripping. The line end is prepared in one go ready for connection according to the Fast Connect standard.

#### Instructions of use

1. Adjust the knives at the side of the stripping tool using a hexagon key.
2. Place the PROFIBUS or Ethernet cable into the stripping tool. Note: Leave the stripped line a bit longer. If need be, it can cut off later.
3. Hold the line tight and rotate the stripping tool around the line. Depending on the line type and the adjustment of the knives 2 to 4 rotations are necessary. Note: Make sure that the line ends to be stripped for assembly are not wrenched.
4. If properly used, the PROFIBUS or Ethernet cable is almost ready for connection so that only the data line needs to be stripped still. Infinitely variable steel blades provide for accurate stripping. Stripping of the cable sheath, braided screen and filler in one go.



Stripping Tools (PROFIBUS and Ethernet)



PROFIBUS Fast Connect Stripping Tool



Ethernet Fast Connect Stripping Tool

Ordering details	Art. No.
PROFIBUS Fast Connect Stripping Tool	110020032
Ethernet Fast Connect Stripping Tool	112020005

Topology plan software TOPOCAD

Function

CAD - software for documentation of automated systems.

TOPOCAD is used to create topology plans on the computer. A comprehensive macrolibrary, for PROFIBUS components for example, allows fast working.

Even unexperienced users will be able to create topology plans after a short period of familiarization. On a clearly arranged user interface the required components are put on the circuit diagram by Drag & Drop. Thanks to a freely definable grid the individual elements can be easily placed and wired. Components can be combined to form groups.

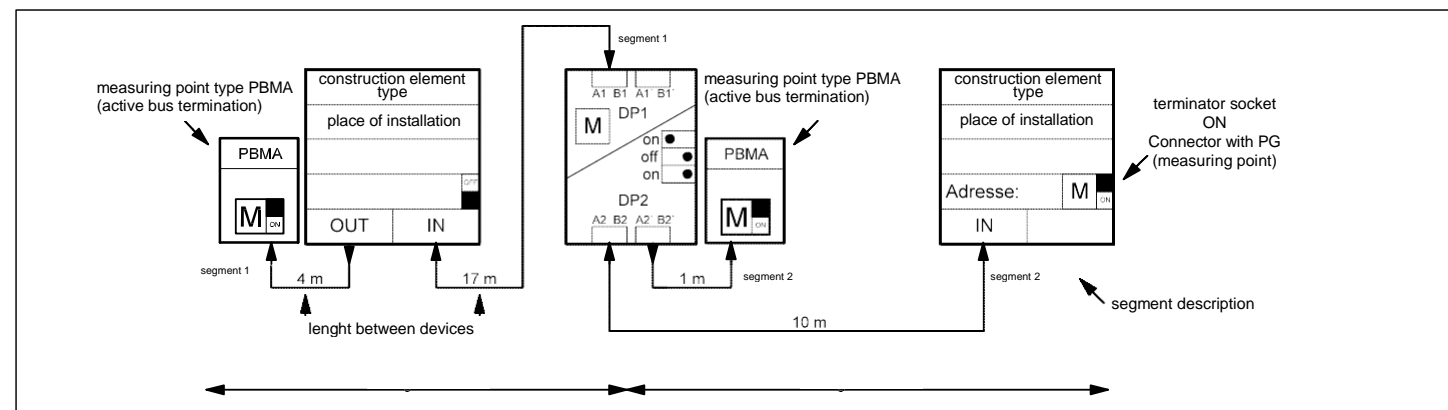
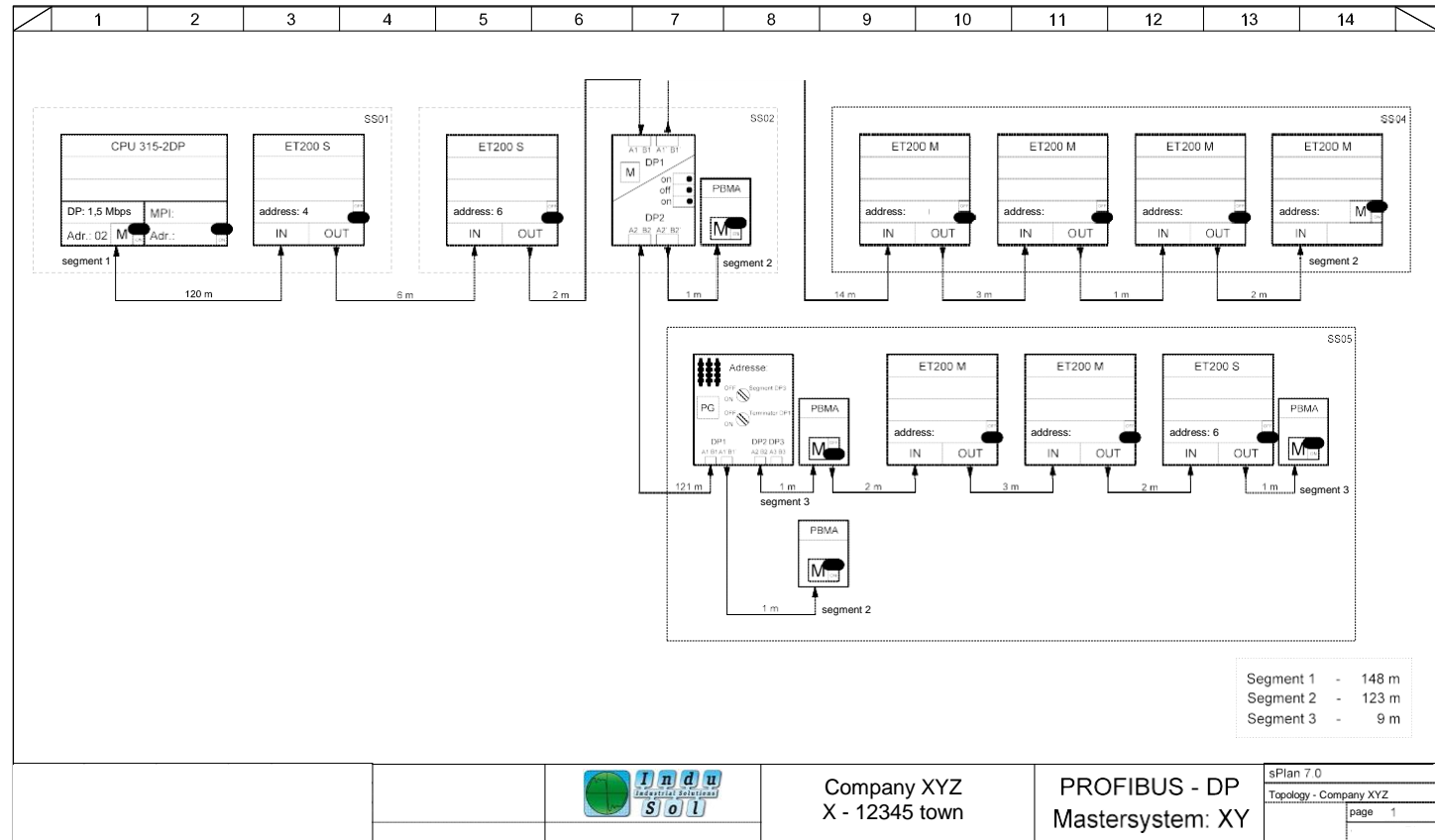

Operating systems

- Windows 98, Windows ME, Windows NT, Windows 2000, Windows XP, Windows Vista, Windows 7, Windows 8

Ordering details	Art. No.
TOPOCAD	110010012

2. Permanent network monitoring (PNM)

Sheet

Introduction permanent network monitoring	38
Decentralized data logger PROFIBUS-INspektor®	40
StarterKIT PROFIBUS-INspektor®	42
INBLOX® Modularer INspektor®	43
Decentralized data logger PROFinet-INspektor®	51
StarterKIT PROFinet-INspektor®	53
Decentralized data logger ASi-INspektor®	54
Decentralized data logger CB-INspektor®	55
Network monitoring software PROmanage®	57
Sample configuration permanent network monitoring	58
OPC Server	60
Topology software PROscan® Active	61

### Permanente fieldbus monitoring enhances availability

„Status-oriented maintenance - condition monitoring - asset management“  
are buzz words in automation technology.

These concepts have something similar in mind: To be able to guarantee smooth production, it is essential to permanently monitor critical components. If their current status is known, the plant operator can take suitable action, before a component fails and production comes to a halt. But what is status-oriented maintenance of individual components good for if the element linking these components, the field bus, is left out of this monitoring process?

#### Network status graphic ~ Condition Monitoring (status-oriented maintenance)

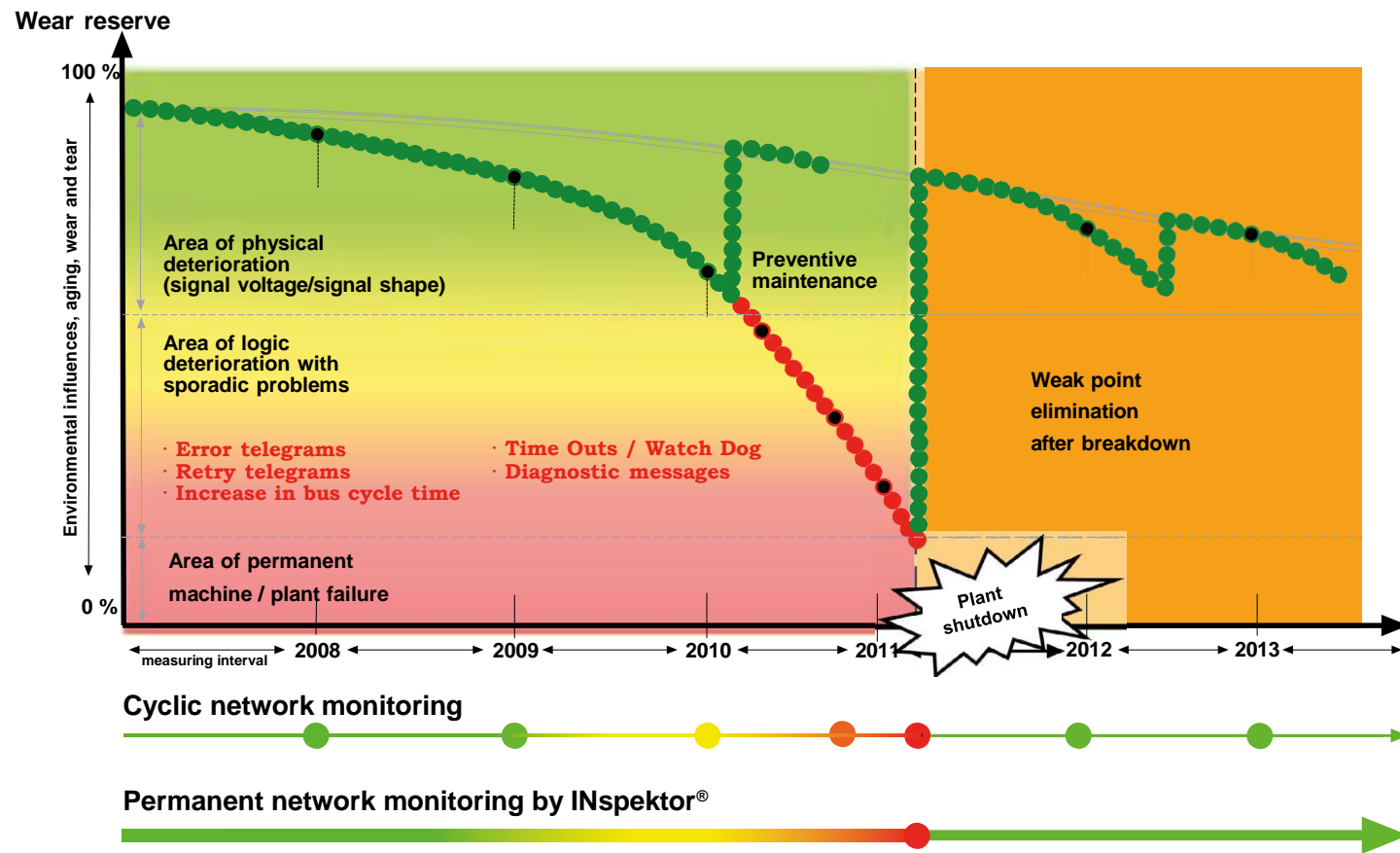

Continuous production can only be ensured and out of the blue failures avoided if beside the individual components the bus is considered a wear part and its status known. In many a case the regular maintenance of the field bus would make sense. But this is not easy to achieve because the number of maintenance staff is decreased for economic reasons. So, the „INspektor“ of Indu-Sol comes in as the ideal partner. It is integrated in the respective network on a permanent basis and monitors constantly the logical data traffic. As a first step Indu-Sol offers inspectors for PROFIBUS, PROFINET, CAN bus and ASI-

nets as well as analyzers for Industrial Ethernet. A central software informs the plant operator both on the current and historical network status. As soon as the communication has exceeded or fallen short of certain quality parameters, the maintenance personnel gets a warning. It is done by a visual display in the software and transfer to the process control system via OPC or SNMP, email or switching of an alarm contact. Thus, it is possible to eliminate causes of fault before a trouble arises and becomes apparent by a plant shutdown.

### INspektor® assesses quality of the industrial communication

The INspektor® has been designed for temporary and permanent network monitoring. It can be integrated into the network under production conditions. For acceptance and test (temporary monitoring) it is monitored for 2 weeks and the quality then assessed in form of a detailed record. After the communication quality has been checked completely the threshold values can be set individually for the network concerned. Criteria used to assess the bus quality are events like faulty telegram, repeats, collisions as well as module failures and diagnostic data. The permanent network monitoring can be carried out on different networks parallel to stationary operation. The determined quality criteria are saved as events in

„INspektor®“ and the Ethernet is used to graphically display the same in the electrical workshop or control station over the entire life cycle of a plant with help of an SNMP query on a central web-based software. The database can be used to create various graphical reports showing current and historical data. To assess the network status typical values for the different field buses or networks have turned out to be useful. Longterm statistics put us in the position for the first time to answer questions on aging, wear and wear reserves, and it is thus possible to determine maintenance intervals that are well-founded in terms of metrology.

#### INspektor® family »Premium-Line«

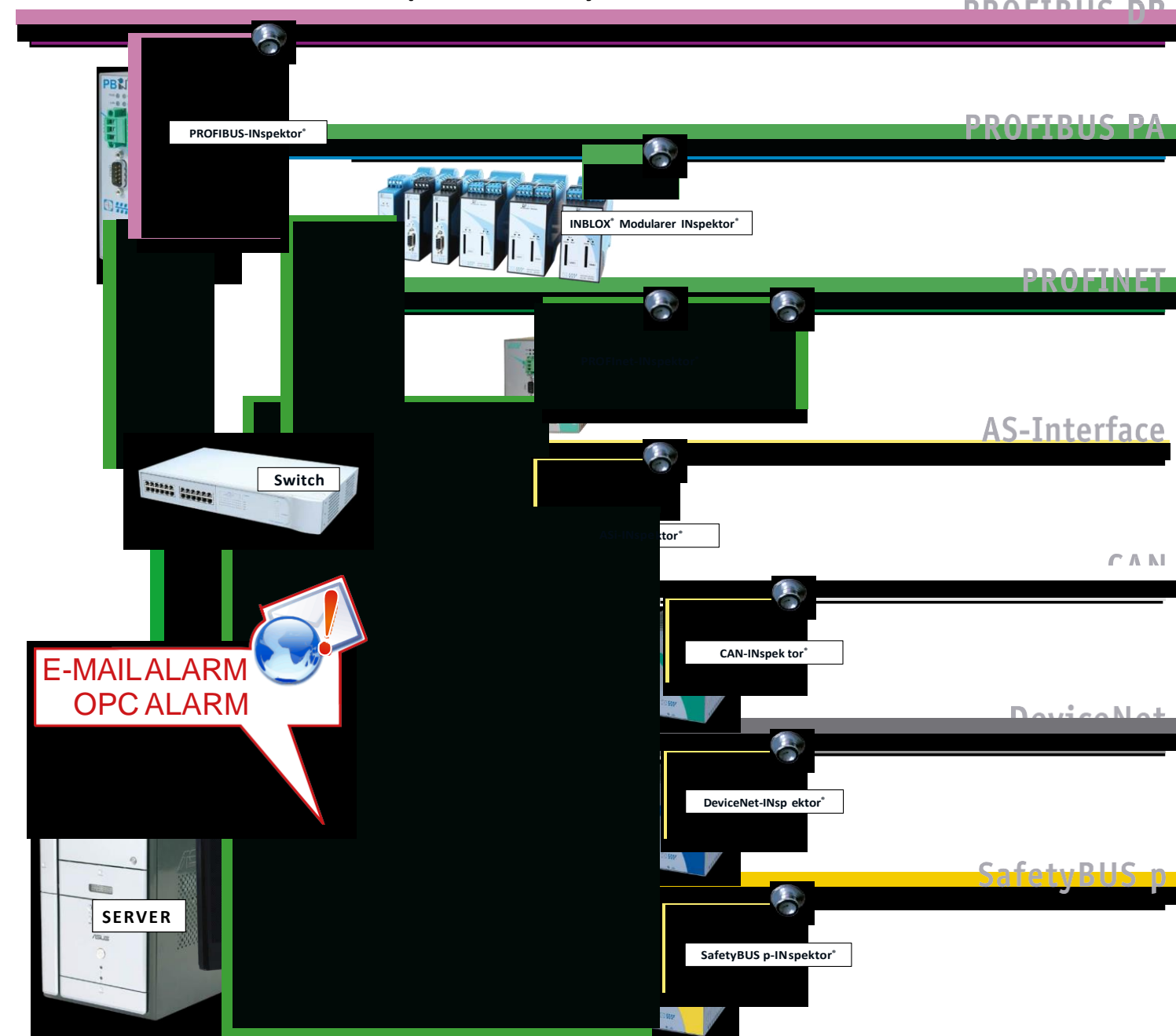

Decentralized data logger PROFIBUS-INspektor®

Function

The PROFIBUS-INspektor® is a passive data logger, analyzing the telegram traffic in the PROFIBUS regarding

- error telegrams
- telegram repeats
- device diagnosis and
- device failures.

This information reflects the current status of the communication quality in the PROFIBUS and is the basis for status-oriented maintenance. For this purpose the user may choose one of the three stages of PB-INspektors®.

Basic Line

The Basic Line is the basic version of the INspektor® family. Depending on the pre-defined trigger functions the events are registered in the PB-INspektor® and summed up and stored per device. The collected network data can be displayed via the Ethernet interface on a local PC. For this purpose the INspektor® has an integrated web server with a graphic web interface. The traffic light colours (green, yellow, red) mark the status of the device and give detailed information on faults. Such faults are indicated via a potential-free contact, e.g. a signal lamp or by visualization.

Comfort Line

For the purpose of an in-depth fault analysis the Comfort Line provides an integrated, fully functional telegram analyzer. The necessary hardware is included in the PB-INspektor® and the external PC is only used for visualization and operation respectively. The telegram analyzer is connected locally via the integrated USB interface.

Premium Line

Based on the Basic Line the Premium Line provides in connection with the PROmanage® software a central control and analysis function. The communication takes place via Ethernet. The central PROmanage® software incl. database can communicate with up to 80 INspektors®. All events are available up-to-date on the database server and are provided for an alarm management „Warning of failure“.

Comfort-Line Plus

Combines Comfort-Line with Premium-Line.

Technical data

- Voltage supply: 24 VDC +/-20 %, typ. 0.3 A
- PROFIBUS
  - Protocols: DP, DPV1, FMS, MPI
  - Connection: 9-pole sub-D
  - Baud rate: 9.6 kbps to 12 Mbps
- Ethernet
  - Baud rate: 100 Mbps / 10 Mbps
  - Connection: RJ45

General data

- Installation: 35 mm DIN top-hat rail
- Dimensions (H x W x D): 131 x 47 x 111 mm
- Industrial protection: IP20
- Ambient temperature: 5 °C to 70 °C
- Storage temperature: -20 °C to 70 °C



PROFIBUS-INspektor®

Functions	Product family PB-INspektor®			
	Basic Line	Comfort Line	Premium Line	Comfort Line Plus
PROFIBUS analysis	X	X	X	X
Web interface	X	X	X	X
Message via potential-free contacts	X	X	X	X
Snapshot incl. viewer	X	X	X	X
Integrated telegram monitor PROFI-TM		X	-	X
SNMP query by PROmanage®	-	-	X	X

INspektoren®-functions

Ordering details	Art. No.
PROFIBUS-INspektor® Basic-Line	124010000
Extension Comfort-Line	124010002
Extension Premium-Line	124010001
Extension Comfort-Line Plus	124010003
Manual (included in delivery)	160000000
<b>Accessories</b>	
PROmanage®	117000003
Aktive programming cable APKA II	110040001
Ethernet patch cable	124080003
Ethernet patch cable cross over power pack 2,5 A	124080003 130010004

Actions to analyse event information in PB-INspektor®

**1. Events in fieldbus e.g. „external device diagnosis“**

**2. Generating an alarm**

**3. View of defective device**

**4. Time stamp of alarm**

**5. Telegram recording of fault (snapshot)**

**6. Evaluating the telegram recording in diagnosis mode (plain text display)**

**7. Evaluating the telegram recording in telegram mode**

**8. Measures to eliminate sources of error prior to Failure !!!**

**StarterKIT PROFIBUS-INspektor®**

**Scope of delivery**

- PROFIBUS-INspektor®
- Power pack
- Aktive programming cable APKA II
- Patch cable cross over (5 m)
- Patch cable
- Line set 24 V / 230 V
- carrying case
- Manual



StarterKIT

**Ordering details**

**Art. No.**

<b>StarterKIT I</b> (incl. Basic-Line)	<b>124010006</b>
<b>StarterKIT II</b> (incl. Premium-Line)	<b>124010007</b>
<b>StarterKIT III</b> (incl. Comfort-Line)	<b>124010008</b>
<b>StarterKIT IV</b> (incl. Comfort-Line Plus)	<b>124010009</b>

**First-time user set PROFIBUS-INspektor®**

**Scope of delivery**

- 4 x PROFIBUS-INspektor® Premium-Line
- 1 x PROmanage® (40 Ports / 5 INspektoren®)



First-time user set

**Ordering details**

**Art. No.**

<b>First-time user set</b>	<b>124010010</b>
----------------------------	------------------

**Permanent network monitoring (2 weeks)**

**Scope of delivery**

- 3 x PROFIBUS-INspektor® Premium-Line
- 1 x PROmanage®
- 1 x laptop
- incl. instructions and evaluation
- detailed record



State graph (PROmanage®)

**Ordering details**

**Art. No.**

<b>Permanent network monitoring (2 weeks)</b>	<b>210070000</b>
---	------------------

**INBLOX® Modularer INspektor®**

**Function**

The **Modular INspektor®** of the **INBLOX®** series is a passive data collector analysing and evaluating logic and physical parameters both in PROFIBUS DP and PROFIBUS PA. Depending on the configuration it is also possible to evaluate a PROFIBUS master by which parameterization can be done via FDT/DTM. You have thus a means to monitor the field bus and the field devices in one single application. Events that can be evaluated in the analysis are

- quality characteristics through bar chart
- error telegrams
- repeat telegrams
- diagnostic messages of individual devices
- device failures
- oscilloscope function – assessment of bit form

An integrated web server displays the network condition on every PC in form of a device-related matrix. It is also possible to store telegram recordings of events on a memory card and display the same separately.

The Modular INspektor® consists of a head module used for connection to the existing Ethernet. It can be extended by up to five modules. By combining diagnosis and parameterization saves cost and time for commissioning and maintenance.



The Modular INspektor® with head module and extension modules

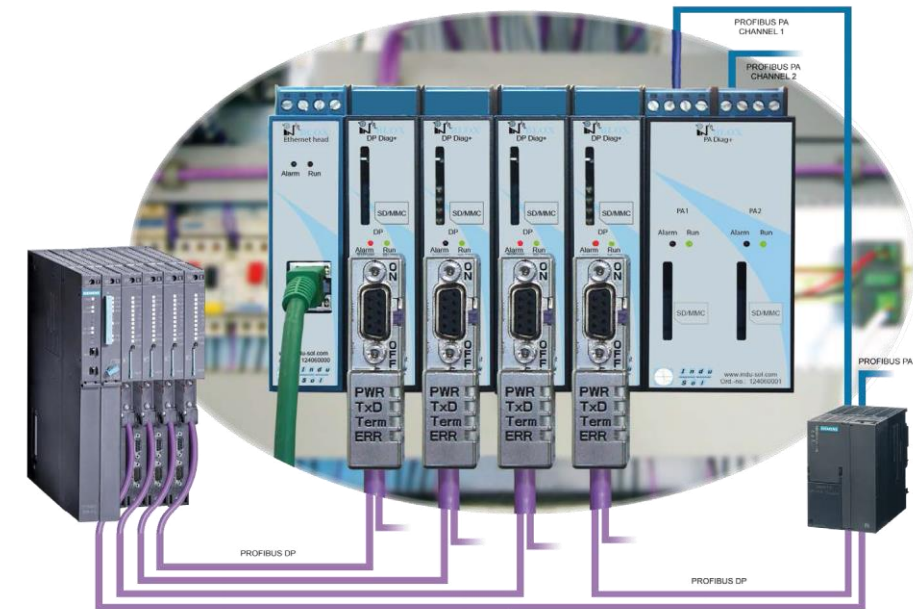

Device matrix terminal assignment

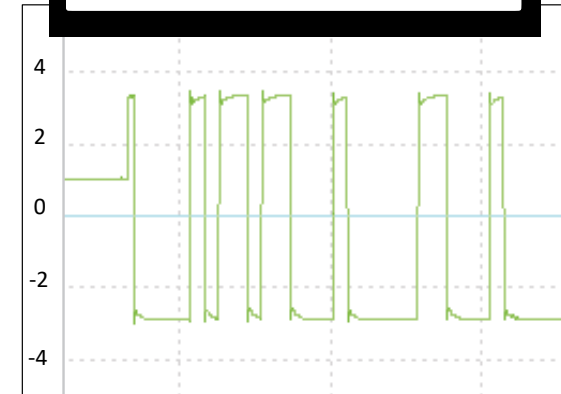

Transfer quality

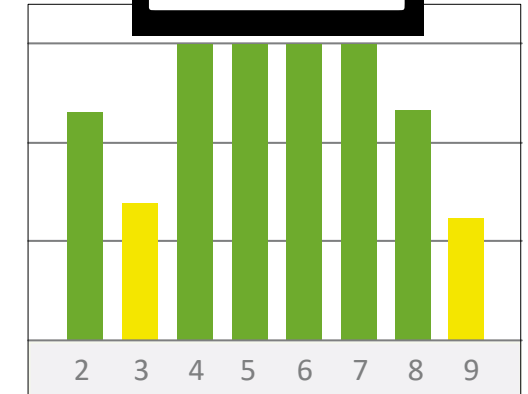

## INBLOX® Ethernet head module

### Function

The **Ethernet head module** is the basis of the premium and comfort version of the INBLOX® series. In addition to its 24 V supply voltage connection it has got a LAN connection for the integrated web server. The head is the core of the smart INBLOX® series and can be extended to max. 20 segments and fi segments resp. by Diag Rep modules and Diag+ Rep modules. An alarm module can be connected in place of a fi extension module. Event alarms are then given by switching contacts.

The E-head is provided with an extended logic and alarms are shown on the web screen as known from the INspektor®. For every extension module a device matrix with certain colours for relevant events can be displayed and the alarms stored as snapshots (up to 100 per extension module).

The head has different options to alert the user in case of network deterioration. It is possible to send an e-mail, an SNMP trap or the INBLOX® can be integrated in a network monitoring software, such as PROmanage®.

### Technical data

- Voltage supply: 24 VDC
- Power supply: 0,3 A
- Connection: screw terminal for 24 V voltage supply
- Baud rate: LAN-Connection for Web interface 9,6 kbps to 12 Mbps
- Ethernet:
  - Baud rate: 100 Mbps / 10 Mbps
  - Connection: RJ45
  - Protocols: IPv4 via DHCP or manual
  - Time server: NTP-time synchronizing

### General data

- Installation: 35 mm DIN top-hat rail
- Dimensions (H x W x D): 114,5 x 22,5 x 99 mm
- Protective system: IP20
- Operating temperature: 5 °C to 55 °C
- Storage temperature: -20 °C to 70 °C
- PROFIBUS-Typen: DP, DP-V1, FMS, MPI
- Extension: DP Diag Rep, DP Diag+ Rep, alarm module
- Automatic alarm: PA Diag+, DP-Master
- E-Mail
- SNMP-Trap
- SNMP-request with PROmanage®

### LED assignment



**Power:** lights up green, if 24 V is connected. **Run:** blinks green at 1 Hz ,rate if everything is o.k.

Ordering details	Art. No.
Ethernet head module (E-head)	124060000

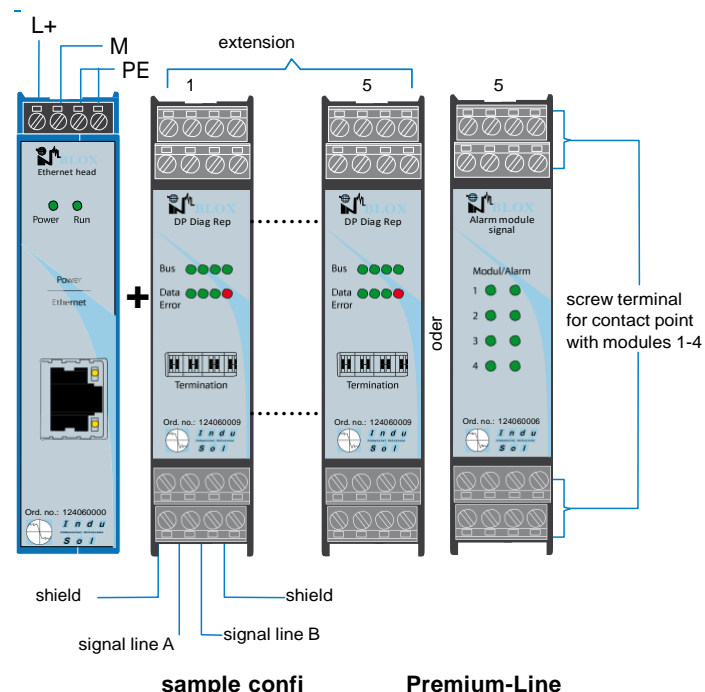
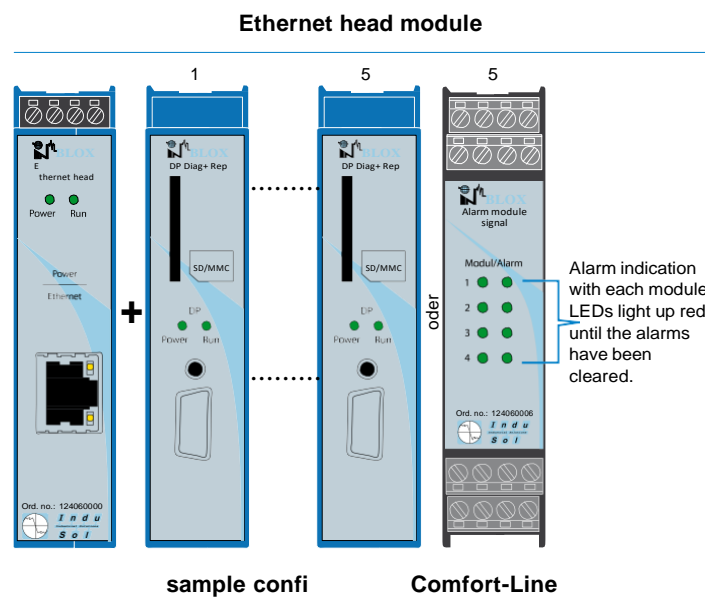

## INBLOX® Ethernet head module

### Web interface

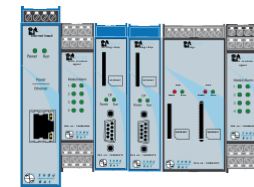

Main page: The module to be viewed can be selected, display of all modules installed

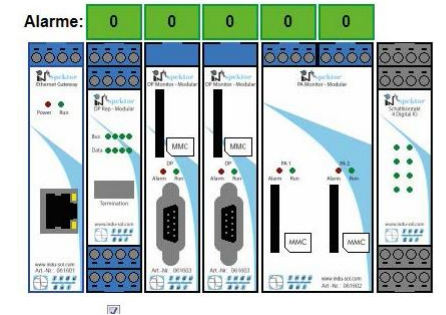

### Main module

- Network
- Email
- SNMP
- Date/Time
- Password
- Firmware
- Restart
- System information

### Main module

### Module 1- DP-Rep

- Snapshots
- Settings
- PB-Devices
- State Calculation

### Node Overview

PB INspektor date/time	Current State	Last Cycle 1 h	History	0 Alarms
06/27/2013 10:11:27 AM	0	0	0	Clear data
Lost Nodes	0	0	0	Data protocol
Restart Nodes	0	0	0	Update rate (10s):
Internal Node Diagnosis	0	0	0	Baud rate:
External Node Diagnosis	0	0	0	6 MB/s
Error telegrams	0	0	0	Device temperature:
Telegram retries per bus cycle	0	0	0	42 C
Total telegram retries	0	0	0	
Network Condition in %	100	100	100	
Start of measurement	06/27/2013 10:11:25 AM	06/27/2013 09:17:25 AM	06/17/2013 03:17:25 PM	
Last SNMP request	(never requested)			

### Overview Nodes

Node Overview	Events/Parameter	Node state							
History	Overview	not existant	Master ok	Master warning	Slave ok	Slave warning	Slave error	present, not projected	not present
0	Device 0 Location 0	Device 1 Location 1	Device 2 Location 2	Device 3 Location 3	Device 4 Location 4	Device 5 Location 5	Device 6 Location 6	Device 7 Location 7	Device 8 Location 8
1	Device 10 Location 10	Device 11 Location 11	Device 12 Location 12	Device 13 Location 13	Device 14 Location 14	Device 15 Location 15	Device 16 Location 16	Device 17 Location 17	Device 18 Location 18
2	Device 20 Location 20	Device 21 Location 21	Device 22 Location 22	Device 23 Location 23	Device 24 Location 24	Device 25 Location 25	Device 26 Location 26	Device 27 Location 27	Device 28 Location 28
3	Device 30 Location 30	Device 31 Location 31	Device 32 Location 32	Device 33 Location 33	Device 34 Location 34	Device 35 Location 35	Device 36 Location 36	Device 37 Location 37	Device 38 Location 38
4	Device 40 Location 40	Device 41 Location 41	Device 42 Location 42	Device 43 Location 43	Device 44 Location 44	Device 45 Location 45	Device 46 Location 46	Device 47 Location 47	Device 48 Location 48
5	Device 50 Location 50	Device 51 Location 51	Device 52 Location 52	Device 53 Location 53	Device 54 Location 54	Device 55 Location 55	Device 56 Location 56	Device 57 Location 57	Device 58 Location 58
6	Device 60 Location 60	Device 61 Location 61	Device 62 Location 62	Device 63 Location 63	Device 64 Location 64	Device 65 Location 65	Device 66 Location 66	Device 67 Location 67	Device 68 Location 68

### Snapshots

Create manual snapshot Delete all snapshots Download all as .zip Display of a snapshot in the PROFIBUS diagnosis Suite

#	Name	Date/Time
100	IS_17934_rpb	07/08/2013 10:39:08 AM
99	IS_17932_rpb	07/08/2013 10:37:40 AM
98	IS_17930_rpb	07/08/2013 03:39:56 AM
97	IS_17929_rpb	07/08/2013 12:50:42 AM
96	IS_17928_rpb	07/07/2013 09:06:18 PM
95	IS_17927_rpb	07/07/2013 07:27:08 PM
94	IS_17926_rpb	07/07/2013 06:35:24 PM
93	IS_17925_rpb	07/07/2013 06:17:30 AM

Time Stamp	Address	Protocol	Primitive	Service	Data
11:15:44.338080	2 -> 2	FDL	Request	FDL STATUS	
11:15:44.338118	2 -> 3	DP	Request	DATA EXCHANGE	01 00
11:15:44.338163	2 <- 3	FDL	Response	SC	
11:15:44.338183	2 -> 4	DP	Request	DATA EXCHANGE	00
11:15:44.338224	2 <- 4	FDL	Response	SC	
11:15:44.338244	2 -> 10	DP	Request	DATA EXCHANGE	00 00 00 00
11:15:44.338316	2 <- 10	DP	Response	DATA EXCHANGE	00 FC E4 FC
11:15:44.338399	2 -> 14	DP	Request	DATA EXCHANGE	
11:15:44.338425	2 <- 14	DP	Response	DATA EXCHANGE	00
11:15:44.338751	2 -> 2	FDL	Request	FDL STATUS	
11:15:44.338790	2 -> 2	FDL	Request	FDL STATUS	

### INBLOX® DP Diag+ Rep

#### Function

The DP Diag+ Rep extension is provided with a D-subminiature connector and can thus open a segment. It is simply connected to the head and is coupled with the backplane bus directly. It obviates the need of a separate voltage supply. Not only peripheral participant and devices can be connected to the segments but also other master systems. Up to five extension modules can be connected to every head. It is thus possible to create up to five segments per head module. The PROFIBUS can be converted from its original line topology to a star topology and spur lines designed without reservation. Each individual segment is monitored by the integrated diagnosis. The alarm LED displays errors diagnosed during monitoring. These DP Diag+ Rep modules require the E-head for design. Via the web interface the device matrix can be displayed and the relevant diagnoses (error telegrams repeat telegrams etc.) read out. The bus physics, too, is permanently monitored for the first time and can be displayed by a bar chart for the quality characteristics or an oscilloscope recording.

#### Technical data

- Voltage supply: 24 VDC with a backplane bus
- Power supply: 0,3 A with a backplane bus
- Connection: 9-pole sub-D PROFIBUS-connection
- Baud rate: 9,6 kbps to 12 Mbps

#### General data

- Installation: 35 mm DIN top-hat rail
- Dimensions (H x W x D): 114,5 x 22,5 x 99 mm
- Protective system: IP20
- Operating temperature: 5 °C to 55 °C
- Storage temperature: -20 °C to 70 °C
- PROFIBUS-types: DP, DP-V1, FMS, MPI
- Characteristics: card slot for SD/MMC memory cards

#### LED assignment



**Alarm:** signal lights red, when alarm is lying ahead



**Run:** lights up green, if everything is o.k.



DP Diag+ Rep

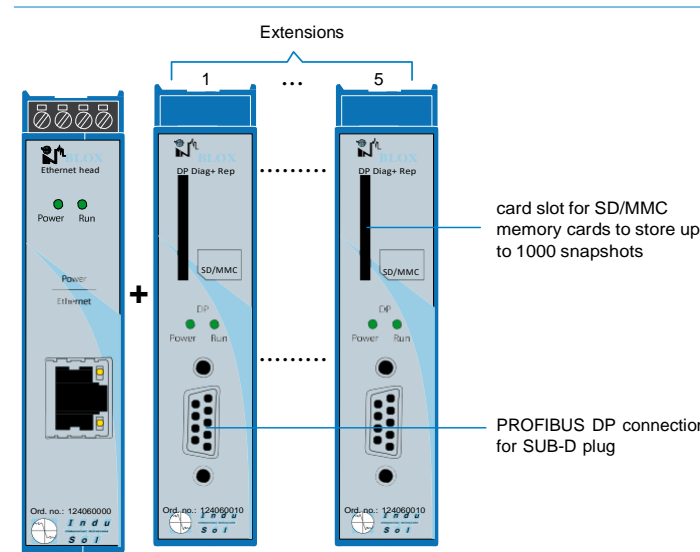

sample confi

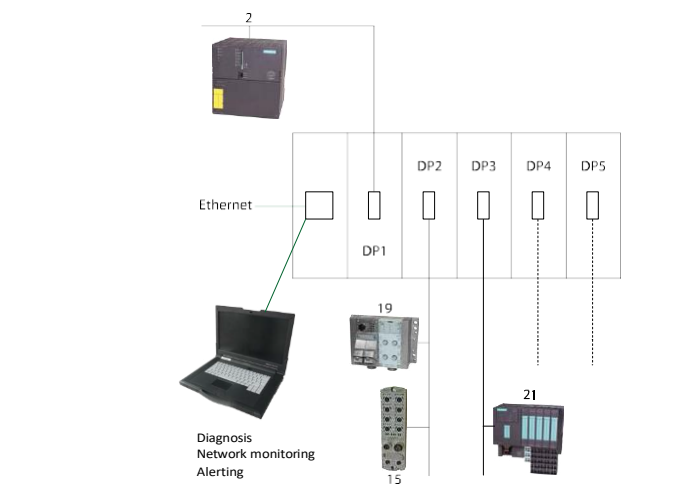

practical example

Ordering details	Art. No.
Extension DP Diag+ Rep	124060010

### INBLOX® DP Diag+ Rep

#### Web interface

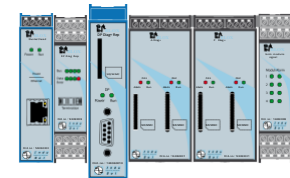

Oscilloscope data 14.03.2013

14.03.2013 13:01:42	🔍	📄
14.03.2013 13:01:44	🔍	📄
14.03.2013 13:01:46	🔍	📄
14.03.2013 13:01:48	🔍	📄
14.03.2013 13:01:51	🔍	📄

Choices of INBLOX® user interface, every module (except I/O module) can be selected with displays showing up. View of quality characteristics of transmission: measurement of bus physics

#### Main module

#### Module - DP-Rep

- Event list
- Snapshots
- Settings
- PB-Devices
- State Calculation
- Firmware

#### Module 3 - DP

#### Module 4 - PA

- Event list
- Snapshots
- Settings
- PB-Devices
- Sate Calculation
- Firmware

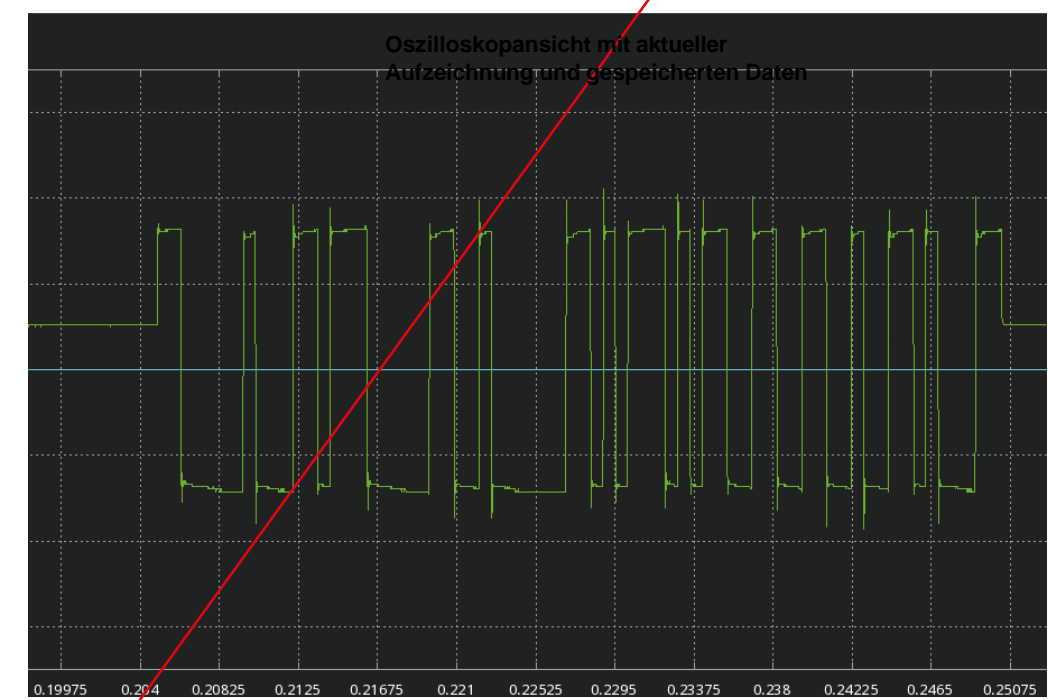

#### Quality rate

Display shows quality figures of the data transfer: measurement of the physical bus characteristics

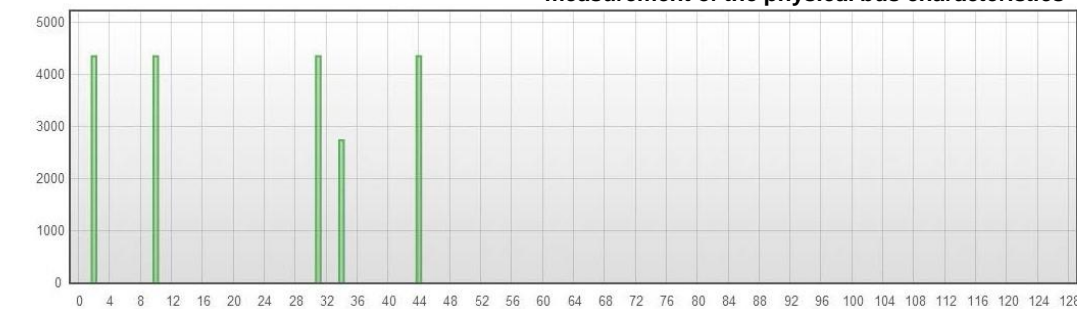

Device	Date	Value	Glitch Flaw Counter	Edge Flaw Counter	Level Flaw Counter	Rising Edge	Falling Edge
2	06/27/2013 10:59:29 AM	2356	0	0	0	1	1
40	06/27/2013 10:59:30 AM	2480	1	0	0	1	1



### INBLOX® DP Diag Master / DP Diag Twin-Master

**Function**

The use of a **DP Diag Master / DP Diag Twin-Master module** for the PROFIBUS DP makes it possible to do FDT/DTM parameterization parallel to all analyses. The parameterization needs not more than a framework application, e.g. PACTware, the logic diagnosis can be retrieved via the web interface of the E-head. It is thus possible to parameterize and confi devices and modules via Ethernet as master class 2. This module combines parameter setting and logical monitoring in one module.

The analysis of the telegram traffi provides information on the number and type of device-related error telegrams. In addition to that it is possible to trigger specifi certain events in order to localize and analyse sporadic errors. Diagnosis telegrams are shown in plain text and make evaluation easier which takes place via the web interface of the Ethernet head.

**Technical data**

- Voltage supply: via head module
- Connection: RS-485 socket
- Baud rate: 9,6 kbps to 12 Mbps

**General data**

- Installation: 35 mm DIN top-hat rail
- Dimensions (H x W xD): DP Diag Master 86 x 22 x 110 mm
- Dimensions (H x W xD): DP Diag Twin-Master 86 x 45 x 110 mm
- Protective system: IP20
- Protocols: DP, DPV1



DP Diag Master / DP Diag Twin-Master

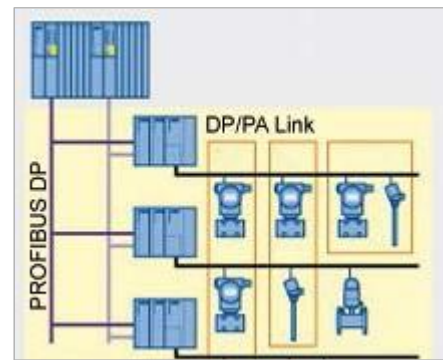

Example of a plant

	0	1	2	3	4
0	00	01	02	03	04
1	10	11	12	13	14
2	20	21	22	23	24

Okay
  Attention
  Failure

Device matrix

### INBLOX® PA Diag+

**Funktion**

The PROFIBUS **PA Diag+ module** is capable of monitoring, analysing and displaying two PA segments at the same time. Like the PROFIBUS DP the PROFIBUS PA analyses and evaluates logic parameters. Besides the error telegrams and repeat telegrams it comprises diagnostic messages of the individual devices and device failures.

**Technical data**

- Voltage supply: via head module
- Power supply: 0,3 A
- Connection: 2 screw terminal
- Baud rate: 31,25 kbps

**General data**

- Installation: 35 mm DIN top-hat rail
- Dimensions (H x W xD): 86 x 45 x 110 mm
- Protective system: IP20
- Protocols: PROFIBUS PA

**Device matrix**

	0	1	2	3	4
0	00	01	02	03	04
1	10	11	12	13	14
2	20	21	22	23	24

Okay
  Attention
  Failure

**Terminal assignment**

**PA Diag+**

Terminal connection

<b>Channel 1</b>	<b>Channel 2</b>
2 PA+	6 PA+
3 PA-	7 PA-
1+4 Shield	5+8 Shield

- Alarm:** signal lights red, when alarm is lying ahead
- Run:** lights up green, if everthing is o.k.

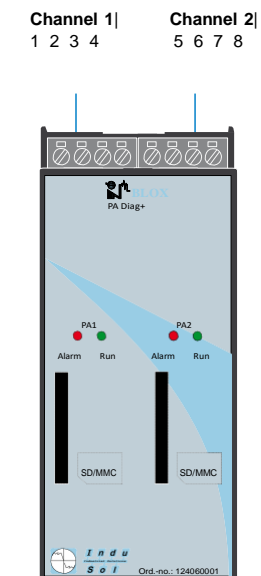

PA Diag+

**PROFIBUS PA diagnosis with PA Diag+**

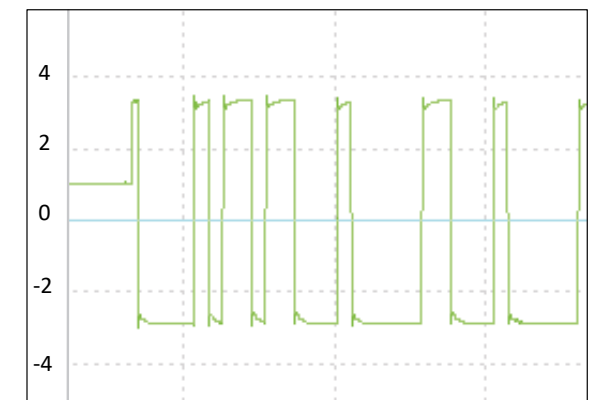

Device matrix terminal assignment

## INBLOX® alarm module

### Function

The **alarm module** comes with four terminals and is capable of monitoring one INBLOX® module per terminal. If available, it is always the last module to be connected and is coupled directly via a backplane bus. Therefore no separate voltage supply is needed. Every terminal/channel has got a switching output for alarms and a reset input. The alarm module can be installed in connection with the E-head only. In case of alarm the alarm LED lights up until it is cleared manually via the web interface or the reset input is actuated. The different alarm LEDs show which INBLOX® module is affected. The web interface of the E-head is used to select the relevant module to show the relevant device and detailed information.

### Technical Data

- Connection: 4 screw terminals
- Voltage supply: 24 V with a backplane bus
- Power supply: 0,3 A with a backplane bus

### General Data

- Installation: 35 mm DIN top-hat rail
- Dimensions (H x W x D): 114,5 x 22,5 x 99 mm
- Protective system: IP20
- Operating temperature: 5 °C to 55 °C
- Storage temperature: -20 °C to 70 °C

### Terminal configuration

#### Alarm module

#### Terminal connection

Alarm for module 1	Alarm for module 2	1   1 2 3 4
1 IN+	5 IN+	
2 IN-	6 IN-	
3+4 OUT	7+8 OUT	

Alarm for module 3	Alarm for module 4	9   9 10 11 12
9 IN+	13 IN+	
10 IN-	14 IN-	
11+12 OUT	15+16 OUT	

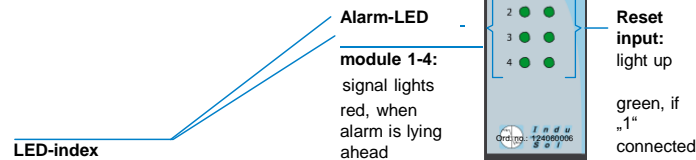

#### LED-index

- Module 1
- Module 2
- Module 3
- Module 4



Alarm module

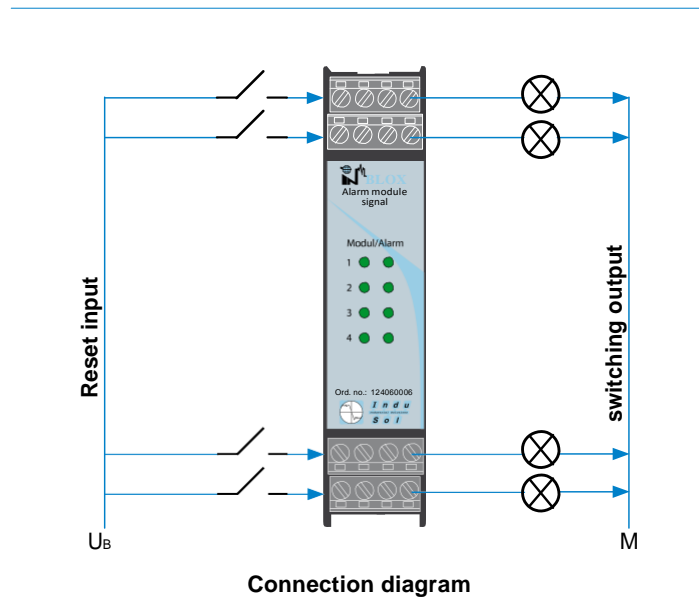

Connection diagram

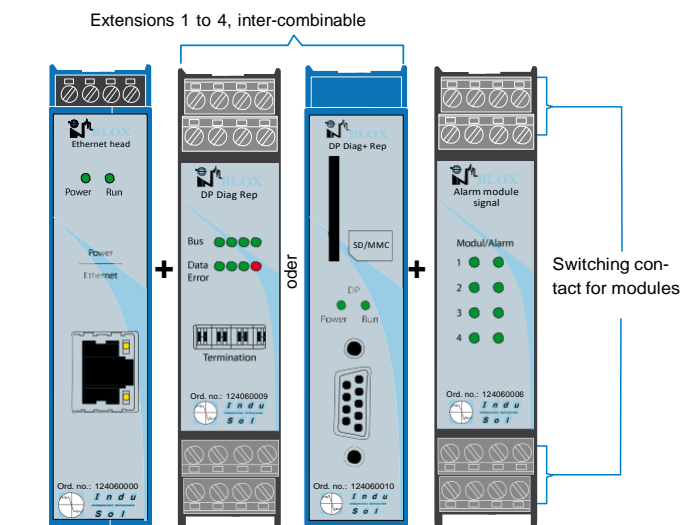

Connection to web interface via LAN

sample confi

Ordering details	Art. No.
Extension alarm module	124060006

## Decentralized data logger PROFINet-INSpektor®

### Function

**PROFINet-INSpektor®** is a passive data collector analysing the telegram traffic in PROFINET but also Ethernet networks for events such as

- utilization rate
- speed
- data throughput,
- telegram jitter,
- repeat telegrams
- error telegrams
- device diagnosis, and
- device failures.

This information reflects the current communication quality on the PROFINET and is the basis for a state-oriented maintenance. To this end the user can use 4 configuration levels of the PN-INSpektor®.

Besides the function as a data collector it serves for reactionless telegram recording in the Ethernet / PROFINET networks under production conditions.

It is recommend to install the PN-INSpektor® permanently within the network connection between the automation device (SPC) and the first IO device or switch resp., because typically most of the communication runs together there.

### Technical data

- Voltage supply: 24 VDC +/-20 %, typ. < 1 A
- PROFINET:
  - Protocols: RT, CBA, Ethernet (IEEE 802.3)
  - Connection: RJ45
  - Baud rate: 10 / 100 Mbps
- Ethernet
  - Baud rate: 10 / 100 Mbps
  - Connection: RJ45
  - MDI/MDIX
- Mirror port
  - Baud rate: 10 / 100 / 1000 Mbps
  - Connection: RJ45
  - MDI/MDIX

### General data

- Installation: 35 mm DIN top-hat rail
- Dimensions (H x W x D): 131 x 110 x 111 mm
- Protective system: IP20
- Ambient temperature: +5 °C to +70 °C
- Storage temperature: -20 °C to +70 °C



PROFINet-INSpektor®

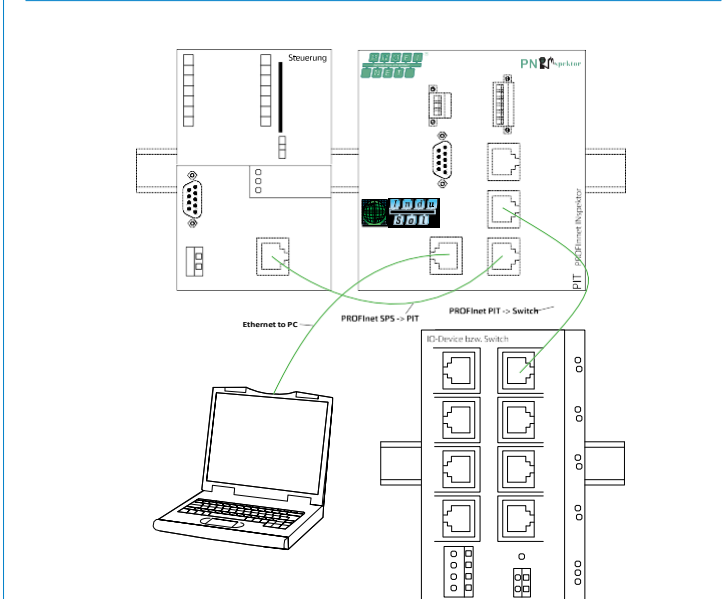

Installation drawing

Decentralized data logger PROInet-INSpektor®

Basic-Line

The Basic Line is the basic version of the INSpektor® family. Depending on the pre-defined trigger functions the events are registered in the PN-INSpektor® and summed up and stored per device. The collected network data can be displayed via the Ethernet interface on a local PC. For this purpose the INSpektor® has an integrated web server with a graphic web interface. The traffic light colours (green, yellow, red) mark the status of the device and give detailed information on faults. Such faults are indicated via a potential-free contact, e.g. a signal lamp or by visualization.

Comfort-Line

For an in-depth error analysis the Comfort-Line provides an integrated fully operative mirror port. The necessary functionalities are already integrated in the PN-INSpektor® and the external PC just serves for visualization and operation respectively. The telegram analyzer is connected locally via the integrated LAN interface. A freeware tool, such as Wireshark, can be used to record all telegrams.

Premium-Line

Based on the Basic Line the Premium Line provides in connection with the PROmanage® software a central control and analysis function. The communication takes place via Ethernet. The central PROmanage® software incl. database can communicate with up to 80 INSpektors®. All events are available up-to-date on the database server and are provided for an alarm management „Warning of failure“.

Comfort-Line Plus

For a comprehensive analysis using snapshots, the mirror port and retrieval of the data via SNMP by PROmanage® the Comfort-Line Plus is the ideal tool for network diagnosis.

Functions	Product family PN-INSpektor® - PIT			
	Basic-Line	Comfort-Line	Premium-Line	Comfort-Line Plus
PROFINET/Ethernet Analysis	X	X	X	X
Web interface	X	X	X	X
Alarms via potentialfreie Kontakte	X	X	X	X
Snapshot	X	X	X	X
unlocked mirror port	-	X	-	X
SNMP-Request with PROmanage®	-	-	X	X

Funktionen der INSpektoren®

Network Overview

Current Time/Data	Last Minute	Last Cycle 24h	History
7/8/2013 12:22:50			
Lost Nodes	0	12	12
High Priority Alarm	0	0	0
Low Priority Alarm	0	0	0
Packetjitter [%]	1	> 500	> 500
Missing RTC Packets	0	0	0
Loading Ratio	369.1	2.1	2.1
Update Rate min/max [ms]	2 / 4	2 / 4	2 / 4
Network Status	100	100	100
Network Loading min/average/max [%]	2.64 / 2.67 / 2.75	2.19 / 2.67 / 3.36	2.19 / 2.67 / 3.36
Throughput maximal [Bytes/ms]	171	171	171
Error Telegrams	0	0	0
Connection Retries maximal	0	12	12
Start of Measurement	7/8/2013 12:22:10	7/8/2013 12:11:02	7/8/2013 12:11:02
Last SNMP Request			

Time	Event	Order	Possible Status
History	IP Adresse	IP-Adresse	
			IO-Device
			Event / Diagnosis
			Last / Restart
			Not responding
			Not monitored
			Asyclic Node
			Duplicate Name / IP-Adresse

Web interface

Ordering details	Art. No.
PROInet-INSpektor® Basic-Line	124030000
Extension Comfort-Line	124030002
Extension Premium-Line	124030001
Extension Comfort-Line Plus	124030003
<b>Accessories</b>	
PROscan® Active	117000014
Ethernet patch cable	124080003
Power pack 2,5 A	130010004

StarterKIT PROInet-INSpektor®

Scope of delivery

- 1 x INSpektor®
- 1 x PROscan® Active
- 1 x Power pack
- 1 x Cross over (5 m)
- 1 x Patch cable
- 1 x Line set 24 V / 230 V
- 1 x carrying case



Ordering details	Art. No.
StarterKIT I (incl. Premium-Line)	124030004
StarterKIT II (incl. Comfort-Line)	124030005
StarterKIT III (incl. Comfort-Line Plus)	124030006



StarterKIT PROInet-INSpektor®

Permanent network monitoring (2 weeks)

Scope of delivery

- 3 x INSpektor® Premium-Line
- 1 x PROmanage®
- 1 x PROscan® Active
- 1 x Laptop
- incl. instructions and evaluation
- detailed record



Ordering details	Art. No.
Permanent network monitoring (2 weeks)	210070001

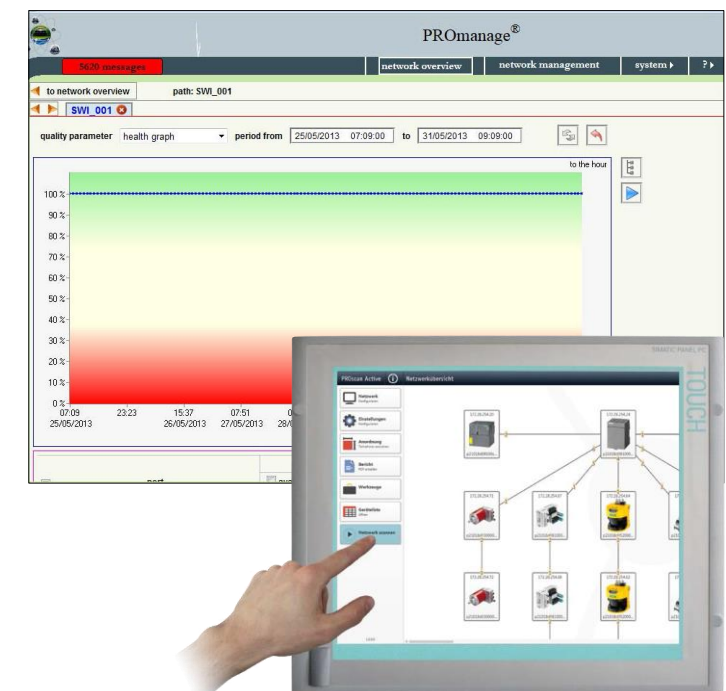

State graph PROmanage® and PROscan® Active

### Decentralized data logger ASi-INSpektor®

**Function**

The **ASi-INSpektor®** is a passive data logger that analyses the telegram traffic of ASi networks for events, such as

- error telegrams,
- repeat telegrams,
- package error
- device diagnosis and
- device failures.

This information reflects the current status of the communication quality in ASi networks. All collected network data can be retrieved via Ethernet using an integrated web interface.

**Technical Data**

- Voltage supply: via ASi network (ASI + / ASI -)
- ASi-Bus
  - Connection: screw terminal
- Ethernet
  - Baud rate: 10 / 100 Mbps
  - Connection: RJ45

**General Data**

- Installation: 35 mm DIN top-hat rail
- Dimensions (H x W x D): 105 x 23 x 111 mm ASi-INSpektor®
- Dimensions (H x W x D): 105 x 23 x 111 mm ASi-INSpektor® with Switch and Pure-box
- Protective system: IP20
- Ambient temperature: 0 °C to +55 °C
- Storage temperature: -25 °C to +85 °C

**Scope of delivery StarterKIT**

- ASi-INSpektor®
- M12 cable to ASi-BUS
- ASiMA (ASi-Messadapter M12)
- Patch cable
- Switch for ASi-INSpektor®
- Pure-box to provide the ASi-INSpektor® web interface
- User manual

Ordering details	Art. No.
<b>ASi-INSpektor®</b>	<b>124040000</b>

**Accessories**

Active measuring point ASiMA IP67	120040000
M12 cable	120010003
Ethernet patch cable	124080003
Ethernet patch cable cross over	124080002

**StarterKIT**

StarterKIT ASi-INSpektor	124040001
--------------------------	-----------



ASi-INSpektor®

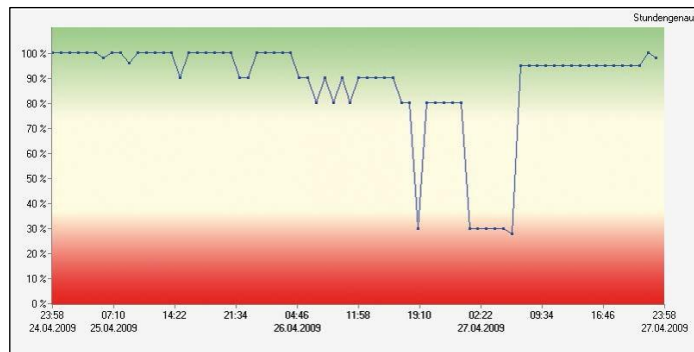

Device list ASi in PROmanage®

possible conditions						
Inaktiv	OK	Event / Diagnostic	Drop out / Restart	present / unprojected		
3	4	5	6	7	8	9
Device 3 Location 3	Device 4 Location 4	Device 5 Location 5	Device 6 Location 6	Device 7 Location 7	Device 8 Location 8	Device 9 Location 9
Device 13 Location 13	Device 14 Location 14	Device 15 Location 15	Device 16 Location 16	Device 17 Location 17	Device 18 Location 18	Device 19 Location 19
Device 23 Location 23	Device 24 Location 24	Device 25 Location 25	Device 26 Location 26	Device 27 Location 27	Device 28 Location 28	Device 29 Location 29

Network status ASi in PROmanage®

### Decentralized data logger CB-INSpektor®

**Function**

The **CB-INSpektor®** is a passive data logger for the CAN fieldbus. The traffic light colours (green, yellow, red) highlight the status of the device and provide detailed information on faults, such as

- error telegrams,
- device diagnoses,
- network utilization and
- device failures.

All network data logged are totalled per device and stored and can be retrieved either via the web-based user interface of the CB-INSpektor® or the Ethernet using the standardized SNMP query protocol and the management software PROmanage®.

Because of the large variety of implemented CAN protocols three different CB-INSpektors® are available to the user.

**Technical data**

- Voltage supply: 24 VDC +/-20 %, typ. 0.3 A
- CAN:
  - Protocols: CAN, CANopen, DeviceNet, SafetyBUS p
  - Connection: 9-pole sub-D
  - Baud rate: 9.6 kbps to 1 Mbps
- Ethernet
  - Baud rate: 10 / 100 Mbps
  - Connection: RJ45

**General data**

- Installation: 35 mm DIN top-hat rail
- Dimensions (H x W x D): 131 x 110 x 111 mm
- Industrial protection: IP20
- Ambient temperature: 5 °C to 70 °C
- Storage temperature: -20 °C to 70 °C

**Scope of delivery StarterKIT**

- |   |  |
|---|--|
| <p><b>CB-INSpektor® CAN / CANopen</b></p> <ul style="list-style-type: none"> <li>• INSpektor® CAN / CANopen</li> <li>• PROmanage®</li> <li>• Patch cable cross over 5m</li> <li>• Carrying case</li> <li>• User manual</li> </ul> | <p><b>CB-INSpektor® DeviceNet</b></p> <ul style="list-style-type: none"> <li>• INSpektor® DeviceNet</li> <li>• PROmanage®</li> <li>• Patch cable</li> <li>• Patch cable cross over 5m</li> <li>• Carrying case</li> <li>• User manual</li> </ul> |
|---|--|

**CB-INSpektor® SafetyBUS p**

- INSpektor® SafetyBUS p
- PROmanage®
- Patch cable
- Patch cable cross over 5m
- Carrying case
- User manual

Ordering details	Art. No.
<b>CB-INSpektor® CAN / CANopen</b>	<b>124050004</b>
<b>CB-INSpektor® DeviceNet</b>	<b>124050005</b>
<b>CB-INSpektor® SafetyBUS p</b>	<b>124050006</b>



CB-INSpektor®

	0	1	2	3	4	5	6	7	8	9
0	Slave 0	Slave 1	Slave 2	Slave 3	Slave 4	Slave 5	Slave 6	Slave 7	Slave 8	Slave 9
1	Slave 10	Slave 11	Slave 12	Slave 13	Slave 14	Slave 15	Slave 16	Slave 17	Slave 18	Slave 19
2	Slave 20	Slave 21	Slave 22	Slave 23	Slave 24	Slave 25	Slave 26	Slave 27	Slave 28	Slave 29
3	Slave 30	Slave 31	Slave 32	Slave 33	Slave 34	Slave 35	Slave 36	Slave 37	Slave 38	Slave 39
4	Slave 40	Slave 41	Slave 42	Slave 43	Slave 44	Slave 45	Slave 46	Slave 47	Slave 48	Slave 49
5	Slave 50	Slave 51	Slave 52	Slave 53	Slave 54	Slave 55	Slave 56	Slave 57	Slave 58	Slave 59
6	Slave 60	Slave 61	Slave 62	Slave 63	Slave 64	Slave 65	Slave 66	Slave 67	Slave 68	Slave 69
7	Slave 70	Slave 71	Slave 72	Slave 73	Slave 74	Slave 75	Slave 76	Slave 77	Slave 78	Slave 79
8	Slave 80	Slave 81	Slave 82	Slave 83	Slave 84	Slave 85	Slave 86	Slave 87	Slave 88	Slave 89
9	Slave 90	Slave 91	Slave 92	Slave 93	Slave 94	Slave 95	Slave 96	Slave 97	Slave 98	Slave 99
10	Slave 100	Slave 101	Slave 102	Slave 103	Slave 104	Slave 105	Slave 106	Slave 107	Slave 108	Slave 109
11	Slave 110	Slave 111	Slave 112	Slave 113	Slave 114	Slave 115	Slave 116	Slave 117	Slave 118	Slave 119
12	Slave 120	Slave 121	Slave 122	Slave 123	Slave 124	Slave 125				

Live List

Graphic display of logic quality parameters in network, early warning alarm when thresholds are exceeded.

**Accessories**

<b>PROmanage®</b>	<b>117000003</b>
<b>Ethernet Patchkabel</b>	<b>124080003</b>
<b>Ethernet Patchkabel Cross over</b>	<b>124080002</b>
<b>Netzteil 2,5 A</b>	<b>130010004</b>

**StarterKIT**

<b>StarterKIT CB-INSpektor® CAN / CANopen</b>	<b>124050007</b>
<b>StarterKIT CB-INSpektor® DeviceNet</b>	<b>124050008</b>
<b>StarterKIT CB-INSpektor® SafetyBUS p</b>	<b>124050009</b>

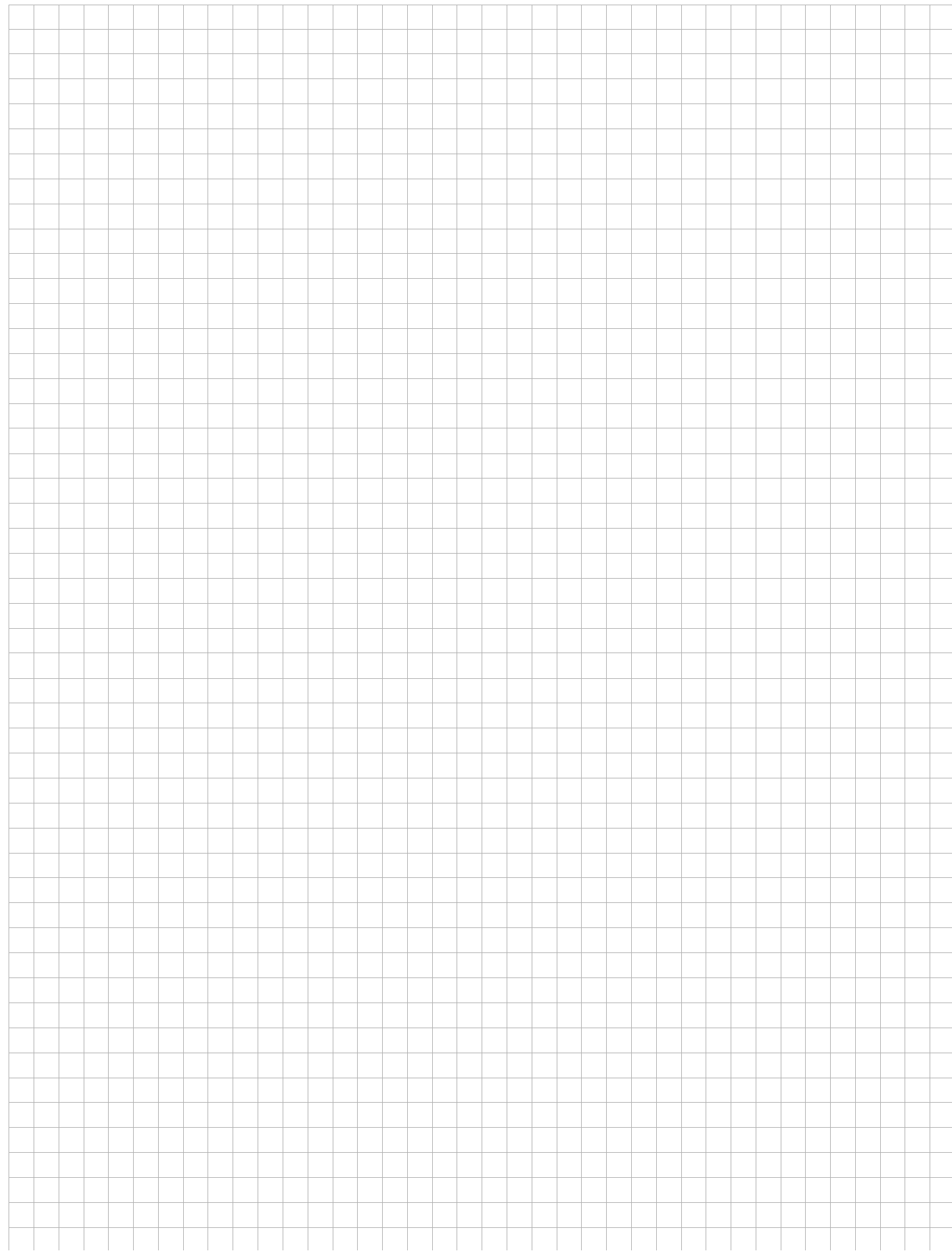

## Network management software PROmanage®

### Function

**PROmanage®** is a central software (incl. database) to analyze, manage and store data of the communication quality in industrial networks. By using the standard SNMP queries all port statistics of the manageable switches can be queried at minute intervals and stored with a time stamp, for example. With this sophisticated analytical technique irregularities can be detected immediately and adjustable thresholds trigger an alarm. Through this statistics function the data are available to the minute up to one year. Thus historic events, such as sporadic failures, can be tracked at any time and used for cause study. For the fieldbus, e.g. PROFIBUS, CAN, ASi, fieldbus controllers, **INspektors®**, have to be installed locally, which are then interrogated centrally by PROmanage®. Thus it is possible to get from this central software at any time information on the condition of the controlled fieldbus, incl. Ethernet. Bottlenecks, gradual deterioration due to component ageing or wear as a result of the production environment can be monitored and displayed in a clearly laid out manner and remedial action taken before failures occur.

### Logging of network data (SNMP)

The network data are logged by the standardized Ethernet protocol „SNMP“ (Simple Network Management Protocol). At a pre-defined interval all INspektors® and switches are queried cyclically by the management software PROmanage® (standard: 1 minute) and the data stored in a MySQL database.

### Display of network data

All collected network data can be displayed on every PC in the network via a web-based interface. The existing Internet browser (Microsoft Internet Explorer or Mozilla Firefox) is used for this purpose. No other software needs to be installed to display the network data. These data are available to the user as statistics (reports) and event messages (event lists).

### Statistics (reports)

Based on PROmanage® a large number of graphic reports with current and historic data can be produced. Depending on the application chronological sequences of the network performance and device-related fault rate can be shown.

### Event messages

With the integrated threshold management limits can be defined for every network parameter. When these limits are reached the event is entered in the event list together with a time and description. Network faults can thus be retrieved by fast click.

### Alarms

An implemented alarm management forwards event messages automatically. By selecting a modern information medium (e-mail, news service) all messages can be transferred to the responsible unit in a timely manner. Transmitting routes can thus be shortened and undesired plant shutdowns avoided.

### Note

The scope of the software depends on the number of Devices to be monitored. In the Ethernet one Device is equal to eight switch ports. *Example Ethernet:* For one manageable switch of 32 ports the resources of 4 Devices have to be reserved in the PROmanage® software. *Example fieldbus:* In the fieldbus one Device is to be reserved in PROmanage® for one INspektor® (distributed data logger).



Network management software PROmanage®

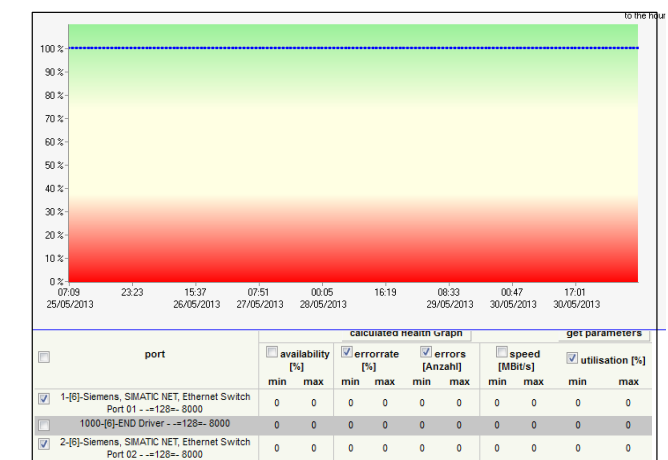

State graph

Ordering details	Art. No.
<b>PROmanage®</b> max. 40 ports / 5 INspektors®	<b>117000001</b>
<b>PROmanage®</b> max. 80 ports / 10 INspektors®	<b>117000002</b>
<b>PROmanage®</b> max. 160 ports / 20 INspektors®	<b>117000003</b>
<b>PROmanage®</b> max. 320 ports / 40 INspektors®	<b>117000004</b>
<b>PROmanage®</b> max. 480 ports / 60 INspektors®	<b>117000005</b>
<b>PROmanage®</b> max. 640 ports / 80 INspektors®	<b>117000006</b>
<b>OPC Server</b>	<b>112010006</b>

Others on request!

Sample configuration permanent network monitoring

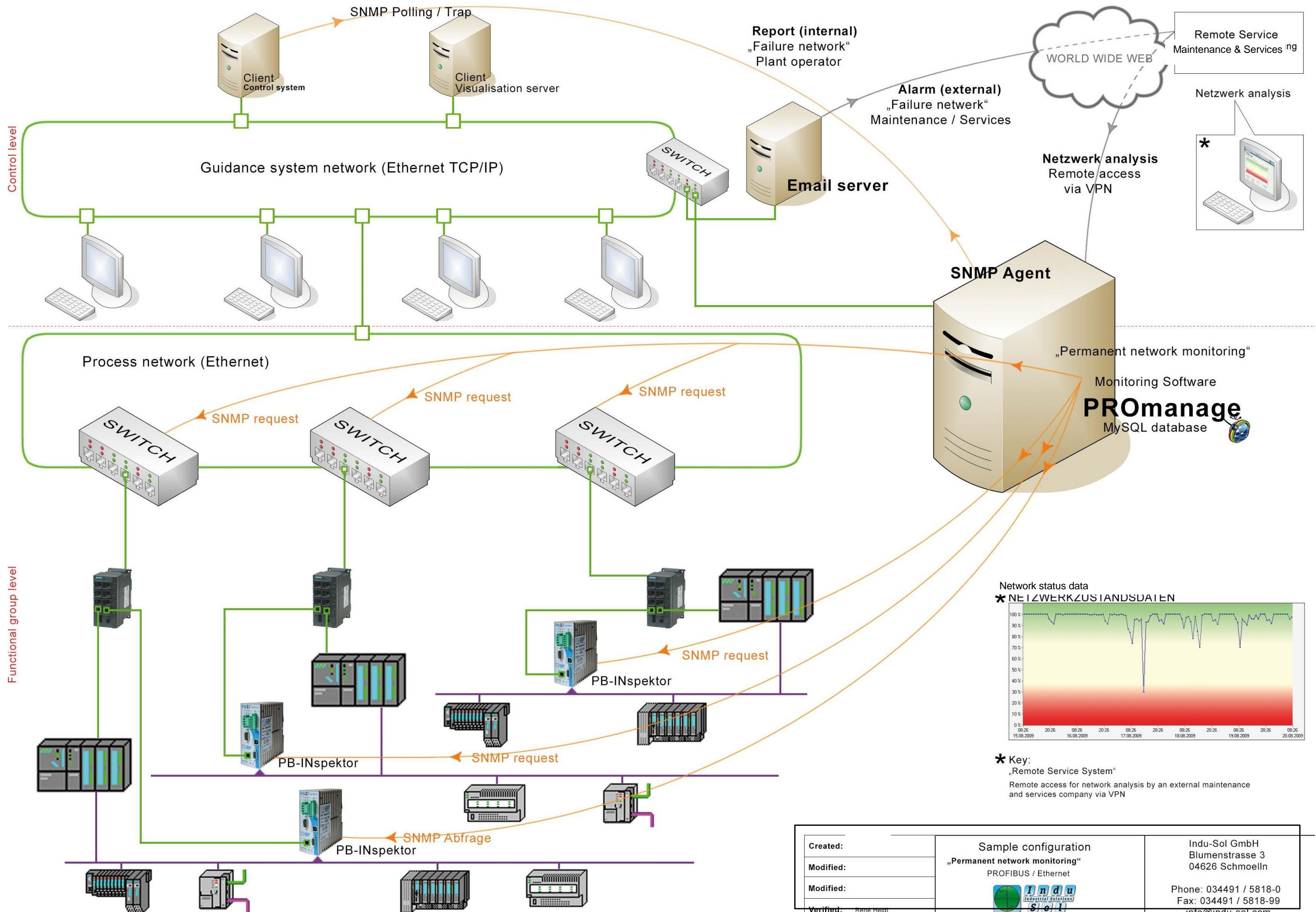

## OPC Server - Field bus warning in the control system

### Function

In connection with the PROmanage® network monitoring software the **OPC server** makes it possible to automatically integrate field bus warnings into a higher-level control system and thus fits the last link in the alarm chain up to the highest control level. Communication errors of field bus systems (PROFIBUS, CAN, ASI, Ethernet) are displayed on the control level in a timely manner thus warning the operator of imminent plant shutdowns. Information on the kind of fault can be gathered from the message received and web-based from PROmanage®.

### Application

Through decentralized data collectors (INspektor® and switches) PROmanage® analyses the field bus systems permanently for communication errors, such as error telegrams, repeat telegrams, device diagnoses and device failures. The collected data are analyzed by a threshold and alarm management and as soon a set trigger has been activated an entry is made in the signal/alarm list. The OPC server gets permanent access to the signal/alarm list and transmits the content of this list after a preceding inquiry by the control system, the OPC client. The messages are then further processed by the control system which can be freely configured by the end user depending on its needs.

### General data

- High-performance OPC server
- Can be configured as Windows service
- Configuration can be changed to running time
- OPC DataAccess 1.0a, 2.0, 2.05a, 3.0, DDE
- Communication via Ethernet and serial interfaces (modem)
- Detailed logging, configurable
- Operation system: Windows 2000, Server2003, XP, Vista, Server 2008

### Scope of delivery

- Software
- Manual

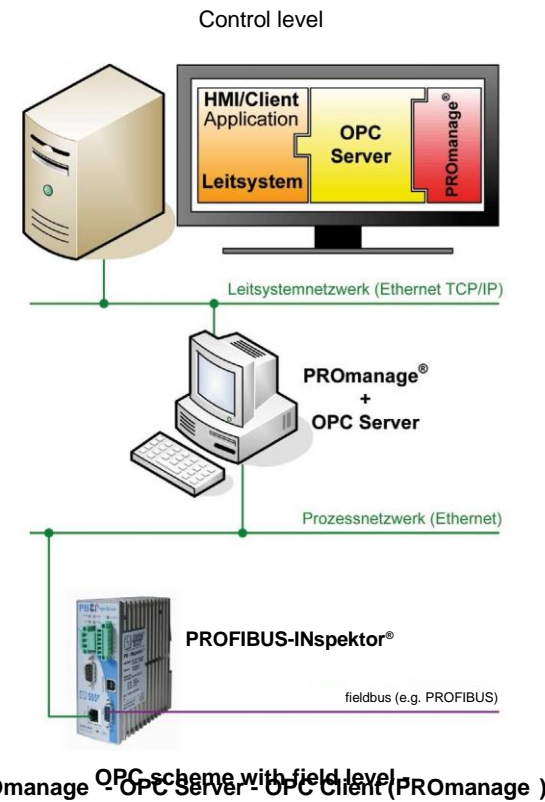

PROmanage OPC schema with field level (PROmanage)

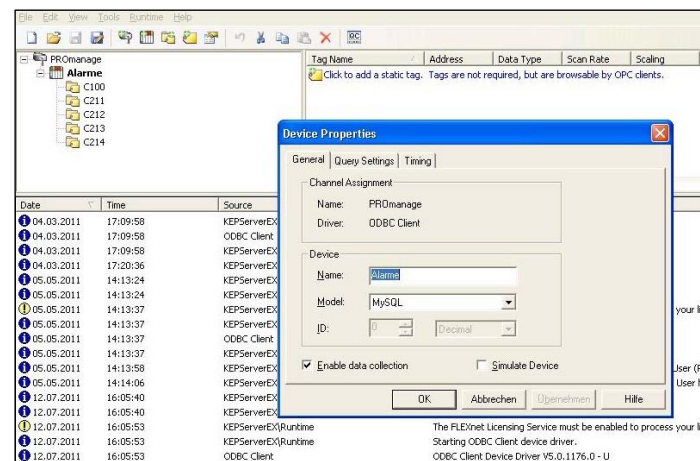

Configuration interface OPC Server

## Topology software PROscan® Active

### Function

**PROscan® Active** is a topology software which provides the user the opportunity to display the actual topology map on a Touch Panel and to print it out directly or to store it as a PDF file. Topology changes from scan to scan are displayed in the colors green and red. The PROscan® Active is optimized for Touch Panel usage and has big buttons available for ensuring a simple and quick operation. To display several network structures multi licences are being offered to allow the user to install the software at different installations. Therewith it is ensured that the actual topology and actual network data can be captured and displayed at all installations. PROscan® Active provides the user the following information which is of a high importance at network care and troubleshooting:

- Display of network devices in there real wiring sequence
- Extended information (for example system code, location, ...) for each SNMP network component
- Portgranular (on a port-by-port basis) location of connected terminal devices
- Line information
  - Line length
  - Power budget (POF)
- Device and topology information
  - PROFINET name
  - IP-address
  - Subnet mask
  - MAC-address
  - Gateway
- Hardware-/ software version
- Device type
- Order number

The topology can be displayed in different forms of expression (hierarchy, symmetrical, circular) after users desire. Already detected network nodes are editable also afterwards.

### Device list

MAC-address	Name	Device type	HW version	SW version
001B1B1CCA44	siemens-391f-3pndp	S7-300	V 5	V 3.2.6
0030DE0384AD	wago-750-340	WAGO-I/O-SYSTEM 75x	V 7	V 1.2.8
00A04536EDC3	phoenix-il-pn-bk	IL PN BK D18 DO4 2TX	V 3	V 2.3.2
001B1B1E1B21	siemens-et200s-links	IM151-3	V 2	V 7.0.1
001B1B1E217A	siemens-et200s-rechts	IM151-3	V 2	V 7.0.1
000F9E053047	murr-mvk-links	MVK ProfiNet	V 1	V 3.1.0
000F9E052FCF	murr-mvk-rechts	MVK ProfiNet	V 1	V 3.1.0
001677008FA1	pn-asi-gw	AS-I	V 2	V 2.0.0
001B1B24DA80	siemens-et200m	IM153-4	V 2	V 4.0.0
001B1B565176	im151-3pn-highfeature	IM151-3	V 8	V 7.0.5
00A045012615	fl-mmhs-reihe-1	FL SWITCH SMCS 8TX-PN	V 1280	V 3.80.0
001B1B3483A6	scalance-x202-2p-irt	SCALANCE X-200	V 5	V 5.0.22
001B1B3AEC7E	scalance-x208-reihe5	SCALANCE X-200	V 6	V 4.4.3
0011FC063700	harting-fts3100-a-links	FTS3100-A	V 256	V 2.2.2
0011FC063460	harting-fts3100-a-rechts	FTS3100-A	V 256	V 2.2.2
00A0456820F9	phoenix-smcs	FL SWITCH SMCS 8TX-PN	V 1280	V 3.80.0
0080636654B0	octopus-8m	Hirschmann OCTOPUS	V 33280	V 4.2.3



Topology display

The diagram shows a network topology with a callout box for a specific device:

- Hostname:** im151-3pn-highfeature
- Description:** Siemens,SIMATIC S7, IM151-3PN HF, 6 ES7 151-3BA23-0A0B, HW:V8.0.0 FW: V7.0.5,SN:SC-D2UP11162013
- Place:**
- Mac address:** 00:1B:1B:56:51:76
- IP address:** 10.1.5.19
- Gateway:** 10.1.5.19
- Subnet:** 255.255.240.0
- DeviceRole:** Device
- DeviceTypeName:** IM151-3
- HardwareVersion:** V8

### Direct device information

The diagram shows a network topology with a callout box for a specific device:

- Device:** 10.1.5.14 port-001 (1)
- Device:** 10.1.5.13 port-002 (2)
- ConnectingType:** optical waveguides (polymer fiber)
- Cable length:** approx. 2.27 m
- Damping:** 0dB

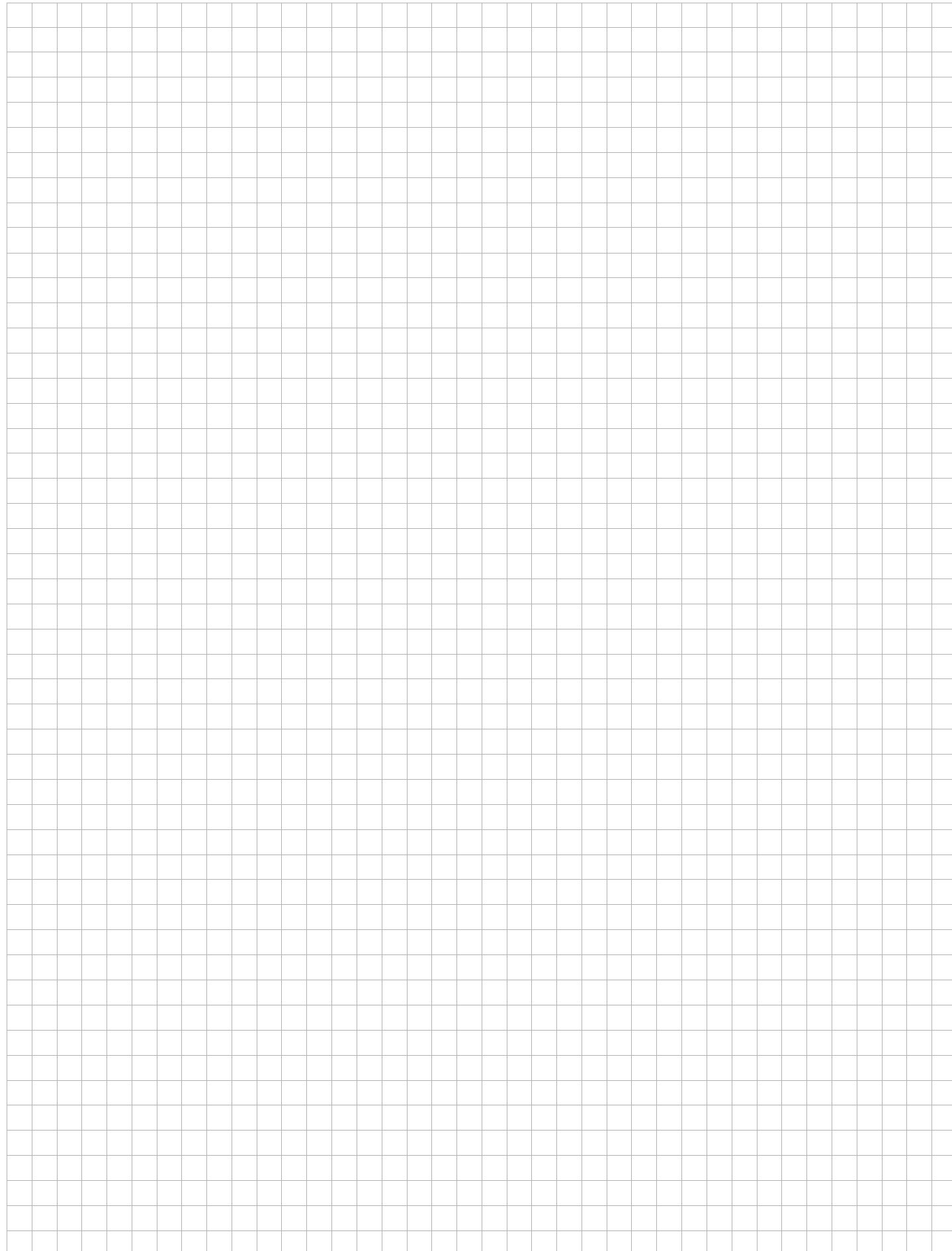

**3. Infrastructure components**

sheet

sheet

**PROFIBUS DP / PA**

**Measuring point**

Active measuring point PBMA IP20

Active adapter PBMB IP20

Active measuring point PBMX IP67

Active measuring point PBMS IP64

Retrofit kit PBMF PB interface electronic

Measuring point PAMA IP67

**Active lines**

Active programming cable APKA

Active programming cable APKA II

Active stub line ASTL

**Connectors**

Diagnostic connector PG/90° screw terminal

Diagnostic connector PG/90° Fast Connect

Diagnostic connector PG/45° Fast Connect

Diagnostic connector axial Fast Connect

Connector PG/90° Fast Connect

Connector PG/90° screw terminal

Connector PG/35° screw terminal

Connector axial screw terminal

Connector M12 with PG 90° compact and standard

Connector M12 with PG 35° spezial

Connector M12 without PG 180° axial

M12 round plug connector FC Plug PRO (B-coded)

M12 round plug connector cord set (B-coded)

M12 terminator socket (B-coded)

64

64

65

66

67

68

69

70

70

71

72

73

73

74

75

76

77

78

79

80

81

82

83

84

85

86

**Repeater**

Built-in repeater DLP30

INBLOX® modularer diagnostic repeater

Standard repeater IP20

Diagnostic repeater IP20

Compact repeater

Repeater IP67 MR (rough conditions)

**Cables & Accessories**

Line standard

Line flexible

Line extrem

M12 Terminator (B-coded) IP67

Control cabinet bushing M12 (B-coded)

T piece M12

T piece M12 compact

T piece M12 (PROFIBUS PA)

Power line M12 (socket, A-coded)

87

87

88

96

97

98

99

100

100

101

102

103

104

105

106

107

108



### Active measuring point PBMA IP20

#### Function

For the purpose of physical determination of the signal-to-noise ratio of the PROFIBUS communication feedback-free measuring points are required in every segment of a master system. To get optimal information on the physical transfer quality, the measuring points have to be provided at the two ends of a segment.

The **PBMA** type meets not only the requirements of a feedback-free measuring point but also fulfils the requirements and the function respectively of an active bus termination.

The Power-LED signals the 24V connection and ensures the 5 V voltage supply for the terminating resistor via an internal DC/DC transformer. The diagnostic tool is connected via the PG / diagnosis interface at the connector.

For a feedback-free connection of a programming device (laptop / field PG) the use of an active programming cable APKA is basically recommended.

#### Bus connection

- Screw terminal technique Fast Connect (needs Fast Connect lines)
- may also be used for highly flexible bus cables
- connection by screw terminals possible on request
- 90° cable outlet

#### Electrical parameters

- Integrated terminating resistance, externally switchable via the sliding switch of the plug
- Baud rate: 9,6 kbps to 12 Mbps
- Input voltage: 24 VDC (20-28 V, pole-proof)
- Output voltage: 5 VDC / 100 mA short-circuit proof Pin 5 (GND) 6 (+)
- Voltage supply through screw terminals

**PE connection (functional earthing) is absolutely necessary!**

#### Ambient conditions

- Operation temperature: 0 °C to +70 °C
- Protective system: IP20

#### Design

- Dimension (H x W x D): PBMA approx. 66 x 16 x 41 mm  
PBMB approx. 77 x 22 x 41 mm
- Weight: approx. 112 g
- Casing: active adapter of plastic material
- Diagnostic plug: plastic material metallized
- Plug w. PG: zinc die cast
- Fastening: snapped on the DIN rail according to EN 50022

Ordering details	Art. No.
<b>PBMA</b> (PBMB + diagnostic plug Fast Connect)	<b>110080001</b>
<b>PBMA</b> (PBMB + diagnostic plug screw terminal)	<b>110080003</b>
<b>Diagnostic plug PG/90° Fast Connect</b>	<b>110050006</b>
<b>Diagnostic plug PG/90° screw terminal</b>	<b>110050009</b>

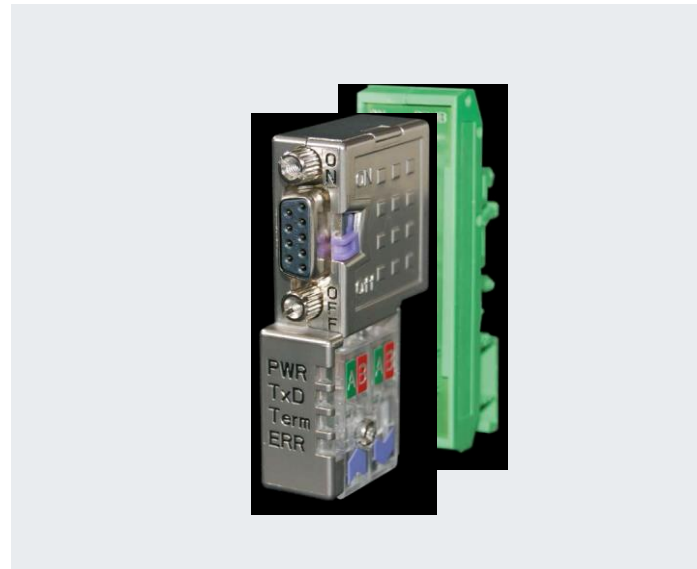

PBMA (incl. active adapter PBMB)



Example of use

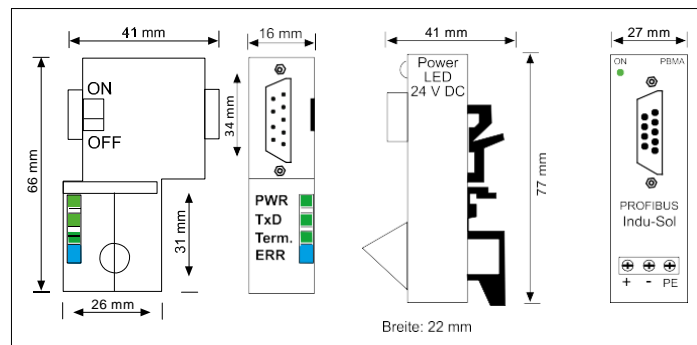

Engineering drawing

### Active adapter PBMB IP20

#### Function

A physical determination of the signal-to-interference ratio of the PROFIBUS communication requires for each segment of a master system non-reactive measuring points. To fully know the physical transmission performance, it is necessary to provide the measuring points at the two ends of a segment.

The **PBMB** can be complemented by a PB plug with a 9-pin D-sub-miniature connector on the back and thus becomes a PBMA. The diagnostic tool is connected via a PG/diagnosis interface at the plug.

For a non-reactive connection of a programming device (Laptop / FieldPG) we basically recommend using an active programming cable, type APKA or APKA II.

#### Elektrische Werte

- Baud rate: 9,6 kbps to 12 Mbps
- Input voltage: 24 VDC (20-28 V, pole-proof)
- Output voltage: 5 VDC / 100 mA short-circuit proof Pin 5 (GND) 6 (+)
- Voltage supply through screw terminals

A PE connection (functional earth) is imperative Cables lead to the field.

#### Ambient conditions

- Operation temperature: 0 °C to +70 °C
- Protective system: IP20

#### Design

- Dimensions (H x W x D): approx. 77 x 22 x 41 mm
- Weight: approx. 36 g
- Casing: active adapter of plastic material
- Fastening: snapped on the DIN rail according to EN 50022
- UL-No.: E218520

Ordering details	Art. No.
<b>PBMB</b> (active adapter)	<b>110080000</b>

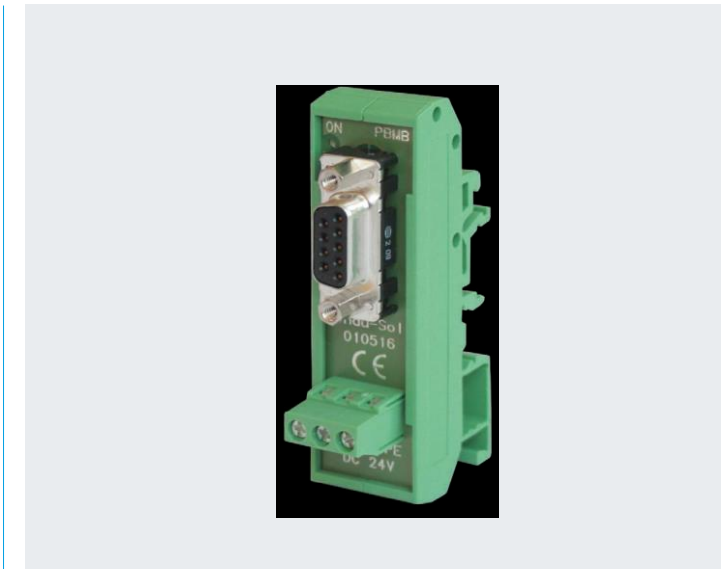

PBMB



Example of use

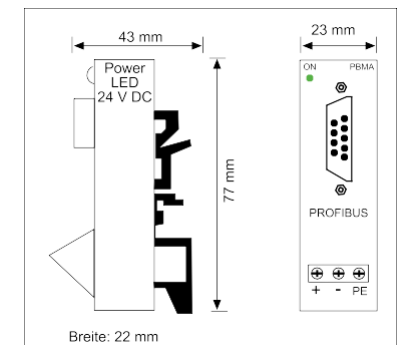

Engineering drawing

### Active measuring point PBMX IP67

#### Function

For the purpose of physical determination of the signal-to-noise ratio of the PROFIBUS communication feedback-free measuring points are required in every segment of a master system. To get optimal information on the physical transfer quality, the measuring points have to be provided at the two ends of a segment

As **PBMX** type with the protective system IP 67 it can be used without protective casing in a rough production environment. The PBMX meets not only the requirements of a feedback-free measuring point but also fulfills the requirements and the function respectively of an active bus termination.

The 24V connection ensures the 5 V voltage supply for the terminating resistor via an internal DC/DC transformer.

The diagnostic tools are connected via the free M 12 measuring socket.

#### Bus connection

- Power: M12 - Connection D (A-coded, dowel)
- Bus: M12 - Connection A (B-coded, dowel) - „incoming“  
M12 - Connection C (B-coded, socket) - „outgoing“
- PG / Diagnosis: M12 - Connection B (B-coded, socket)

#### Electrical parameters

- Baud rate: 9,6 kbps to 12 Mbps
- Rated voltage: 24 VDC
- Rated current: Pin 2 / 4 0,25 A  
Pin 1 / 3 / 5 2,00 A
- Input voltage: 24 VDC (18 to 30 VDC, pole-proof)
- Output voltage: 5 VDC (100 mA) Pin 1/3  
(5 V tapping at sockets B and C)

#### Ambient conditions

- Temperature range: -20 °C to +80 °C
- Industrial protection: IP67
- Degree of pollution: 3

#### Design

- Casing: nickel-plated zinc die cast
- Input / Output: EMV electromechanical screw-joint
- Outlet: M12 plug-and-socket connector
- Number of contacts: 5 gilt copper
- Weight: approx. 210 g
- Fastening: M5 x 1 bolt (thread at the back)

#### Ordering details

**PBMX - Set** **110080005**

The PBMX-Set comprises (ready-to-install items):

- 1 x active measuring adapter PBMX (bus termination)
- 1 x power cable M12 (female), standard length 3 m
- 1 x unilaterally converted PROFIBUS cable (female) 2 m
- 1 x M12 bus termination (male)
- 1 x M12 blind closure

**PBMX - single** **110080004**



PBMX

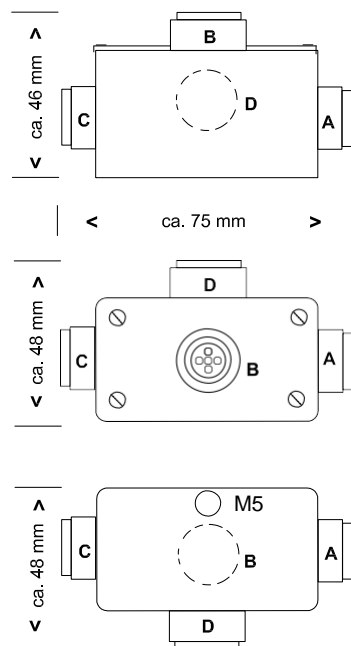

Engineering drawing

<b>A</b>	Bus "coming"		1: not used 2: A-Line (green) 3: not used 4: B-Line (red) 5: shield
<b>B</b>	diagnostic and programmer interface		1: 5 V 2: A-Line (green) 3: a V (blue) 4: B-Line (red) 5: shield
<b>C</b>	Bus "going"		1: 5 V 2: A-Line (green) 3: a V (blue) 4: B-Line (red) 5: shield
<b>D</b>	Power (24 V DC)		1: 24 V (brown) 2: not used 3: a V (blue) 4: not used 5: not used

Pin assignment

### Active measuring point PBMS IP64

#### Function

The measuring and programming interface **PBMS** for front mounting in the control cabinets and terminal boxes provides for a simple and optimal access to the internal MPI or PROFIBUS interface. The integrated electronic system allows a feedback-free plugging of PROFIBUS analyzers while the system is running. To get an optimal understanding of the physical transfer quality, it is necessary to arrange the measuring points at the two ends of a segment. The PROFIBUS connector located on the rear side (inside the cabinet) meets the requirements and fulfills the function of an active bus termination. The diagnostic tool is connected via the 9-pin sub-D PG / diagnosis interface at the front under the cover. Depending on requirements the USB or RJ 45 type can be requested, too. For a feedback-free connection of a programming device (laptop / field PG) to the sub-D socket an active programming cable APKA is basically recommended.

The type PBMS-D (double) has a mains socket-outlet next to the measuring socket. The socket is available in different versions depending on the local standard.

#### Bus connection

The connection to the PROFIBUS is executed through a commercially available PROFIBUS plug including a terminating resistor that can be switched on.

#### Electrical parameters

- Baud rate: 9,6 kbps to 12 Mbps
- Input voltage: 24 VDC (18 to 30 V, pole-proof)
- Output voltage: 5 VDC / 100 mA; short-circuit proof  
Pin 5 (GND); Pin 6 (+5V)
- Connections fed through screw-type terminals

#### Electrical parameters - Socket outlet

- |                         |          |          |          |
|-------------------------|----------|----------|----------|
| • Norm:                 | D VDE    | USA NEMA | F UTE    |
| • Rated voltage (max.): | 250 V AC | 125 V AC | 250 V AC |
| • Frequency:            | 50 Hz    | 60 Hz    | 50 Hz    |
| • Rated current (max.): | 16 A     | 15 A     | 16 A     |

#### • Further on request

#### Ambient conditions

- Industrial protection: IP64

#### Design

- Dimensions (H x W x D): PBMS-E 115 x 65 x 38 mm (single)  
PBMS-D 115 x 130 x 78 mm (double)
- Weight: PBMS-E = 340 g  
PBMS-D = 800 g
- Frame: metal
- Cap: metal, black coat

#### Ordering details

Ordering details	Art. No.
<b>PBMS-E schwarz</b> (single)	<b>110080008</b>
<b>PBMS-D schwarz</b> (double, with german socket)	<b>110080009</b>
<b>PBMS-B schwarz International</b> (double)	<b>110080010</b>
<b>PBMF PB-interface electronics</b> (retrofit kit)	<b>110080007</b>



PBMS

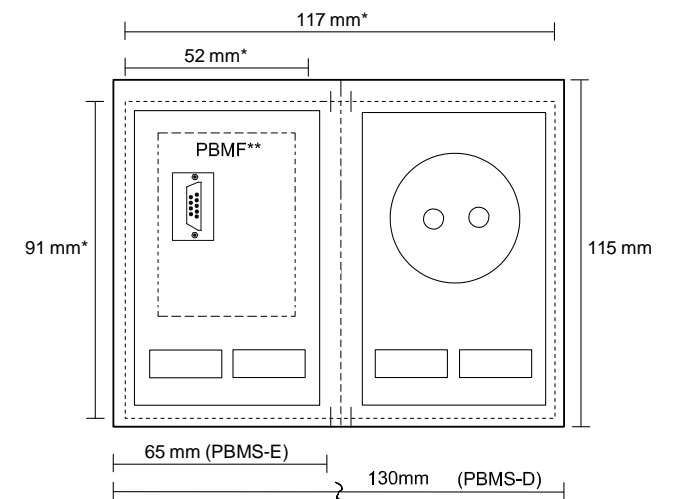

\*\* ) electronic PBMF connection back-mounted

Engineering drawing

The local type of socket must be indicated separately in the order (PBMS black „International“):

- e.g.
- USA
  - Great Britain
  - France

To avoid reflections, we recommend to connect PG / PC devices always via active programming cables APKA.

#### Accessories

<b>Active programming cable APKA</b>	<b>110040000</b>
<b>Active programming cable APKA II</b>	<b>110040001</b>

### Retrofit kit PBMF PB interface electronics

#### Function

The retrofit kit PBMF is the electronic unit of the measuring and programming interface PBMS IP64 - active termination. This kit must always be installed with a specially developed metal frame for use in control cabinets and terminal boxes.

By this electronic unit the requirements of a feedback-free measuring point and the requirements and function resp. concerning an active bus termination are met.

The connection to the PROFIBUS DP/MPI on the rear side is rendered by a commercially available PROFIBUS connector with a selectable terminating resistor. The diagnostic tools are connected via the 9-pole sub-D socket.

For the feedback-free connection of a programming cable (laptop / field PG) to the sub-D receptacle an active programming APKA is basically recommended.

#### Bus connection

The connection to the PROFIBUS is rendered through a commercially available PROFIBUS connector with selectable terminating resistor.

#### Electrical parameters

- Baud rate: 9,6 kbps to 12 Mbps
- Input voltage: 24 VDC (18 to 30 V, pole-proof)
- Output voltage: 5 VDC / 100 mA short-circuit proof  
Pin 5 (GND); Pin 6 (+5V)
- Connection: screw terminal

#### Design

- Dimensions (H x W x D): 89 x 50 x 27 mm
- Weight: 48 g



PBMF - front view



PBMF - back view

Ordering details	Art. No.
Retrofit kit PBMF PB interface electronics	110080007

To avoid reflections, we recommend to connect PG / PC devices always via active programming cables APKA.

#### Accessories

Active programming cable APKA	110040000
Active programming cable APKA II	110040001

Ordering details	Art. No.
Measuring point PAMA	110080011

### Measuring point PAMA IP67

#### Function

A physical determination of the signal-to-interference ratio of the PROFIBUS PA communication requires for each segment of a master system non-reactive measuring points. The PAMA variant meets the requirements of a non-reactive measuring point. The diagnostic tool is connected via the M12 connector of the measuring point.

#### Electrical parameters

- Baud rate: 31,25 kbps
- Connection: insulation displacement connector technology
- Shock stress: 30 g / 11 ms
- Vibration stress: 10 to 58 Hz, 0,075 mm Amplitude

#### Ambient conditions

- Temperature range: -40 °C to +85 °C
- Protective system: IP67 (Only if all outlets are correctly loaded)

#### Design

- Dimensions (H x W x D): 56,5 x 85 x 62 mm
- Weight: 169 g
- Casing: PBT with 10 % GF + 10 % CF
- Measuring point: M12 - socket as measuring point
- Fastening: by clip on DIN rail or on the wall



PAMA IP67

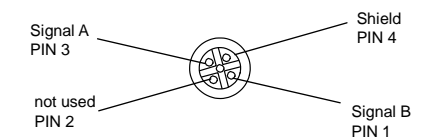
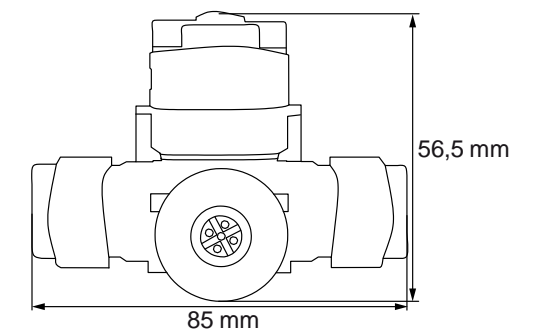

Pin 1: Signal B  
Pin 2: Not used  
Pin 3: Signal A  
Pin 4: Shield

Engineering drawing

## Active programming cable APKA

### Funktion

By the repeater integrated in the plug, the **active programming cable APKA** facilitates a reactionless plugging on the PROFIBUS to program and check the logic communication quality. The 5 V supply required for repeater operation shall be made available through the pin 5 (GND) and the pin 6 (+5 V) of the contacted 9-pin sub-D socket. It can be basically assumed that all slaves of the PROFIBUS norms support the relevant pin assignment.

### Application instruction

The connector X1 with repeater function has to be plugged on the PROFIBUS and MPI interface respectively.

Important:

The active programming cable can not be used for connecting a bus user through a stub line. For this purpose the active stub line ASTL is to be used.

### Connection

- 9-pin sub-D plug with integrated repeater (cable outlet 70°)
- 9-pin sub-D plug (axial cable outlet)

### Electrical parameters

- Baud rate: 9,6 kbps to 12 Mbps
- Supply voltage: 4.75 - 5.25 VDC has to be provided by each PROFIBUS user (Pin 5 GND, Pin 6 +5V)

### Design

- Weight: approx. 230 g
- Length: 3 m

### Pin assignment

Connector X1, connection measuring (repeater function)

Pin	Function	Note
1	not used	
2	M24	connects to X2 Pin 2
3	B	RS 485 data
4	RTS - AS	connects to X2 Pin 4
5	GND	connects to X2 Pin 5
6	VCC	supply voltage +5V
7	P24	connects to X2 Pin 7
8	A	RS 485 data reversed
9	not used	

Connector X2, connection slave

Pin	Function	Note
1	not used	
2	M24	connects to X1 Pin 2
3	B	RS 485 data
4	RTS - AS	connects to X1 Pin 4
5	GND	connects to X1 Pin 5
6	not used	
7	P24	connects to X1 Pin 7
8	A	RS 485 data reversed
9	RTS - RG	used for switching between send / receive

Ordering details	Art. No.
Active programming cable APKA	110040000



APKA

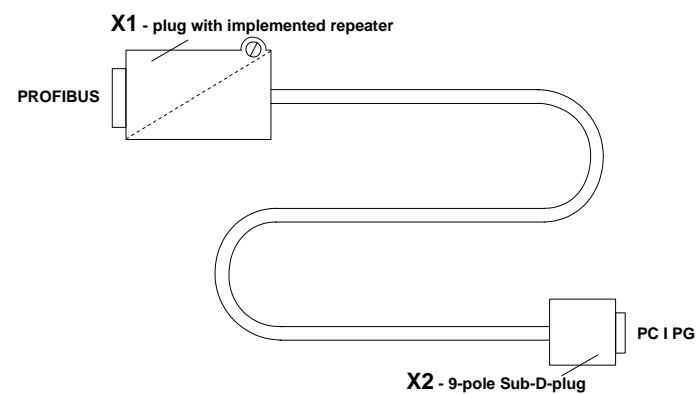

Engineering drawing

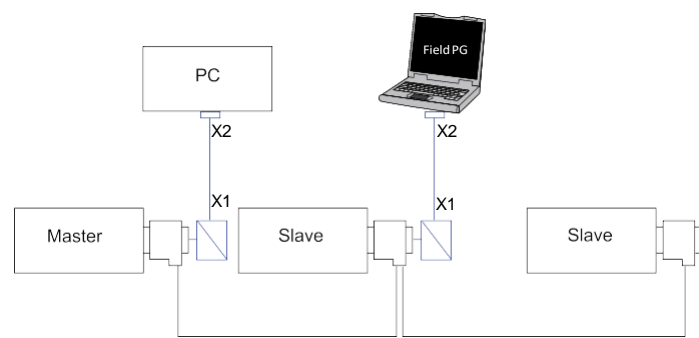

Example of use

## Active programming cable APKA II

### Funktion

By the repeater integrated in the plug, the **active programming cable APKA II** facilitates a reactionless plugging on the PROFIBUS to program and check the logic communication quality. The 5 V supply required for repeater operation shall be made available through the pin 5 (GND) and the pin 6 (+5 V) of the contacted 9-pin sub-D socket. It can be basically assumed that all the slaves of the PROFIBUS norms support the relevant pin assignment.

### Application instruction

The connector X1 with repeater function has to be plugged on the PROFIBUS and MPI interface respectively.

Important: The active programming cable cannot be used for connecting a bus user through a stub line. For this purpose the stub line ASTL is to be used.

### Connection

- 9-pin sub-D plug with implemented repeater (cable outlet 35°)
- 9-pin sub-D plug (axial cable outlet)

### Electrical parameters

- Baud rate: 9,6 kbps to 12 Mbps
- Supply voltage: 4,75 to 5,25 VDC has to be provided by each PROFIBUS user (Pin 5 GND, Pin 6 +5V)

### Design

- Weight: approx. 230 g
- Length: 3 m

### Pin assignment

Connector X1, connection measuring (repeater function)

Pin	Function	Note
1	not used	
2	M24	connects to X2 Pin 2
3	B	RS 485 data
4	RTS - AS	connects to X2 Pin 4
5	GND	connects to X2 Pin 5
6	not used	
7	P24	connects to X2 Pin 7
8	A	RS 485 data reversed
9	not used	

Connector X2, connection slave

Pin	Function	Note
1	not used	
2	M24	connects to X1 Pin 2
3	B	RS 485 data
4	RTS - AS	connects to X1 Pin 4
5	GND	connects to X1 Pin 5
6	VCC	supply voltage +5 V
7	P24	connects to X1 Pin 7
8	A	RS 485 data reversed
9	RTS - RG	used for switching between send/receive

Ordering details	Art. No.
Active programming cable APKA II	110040001



APKA II

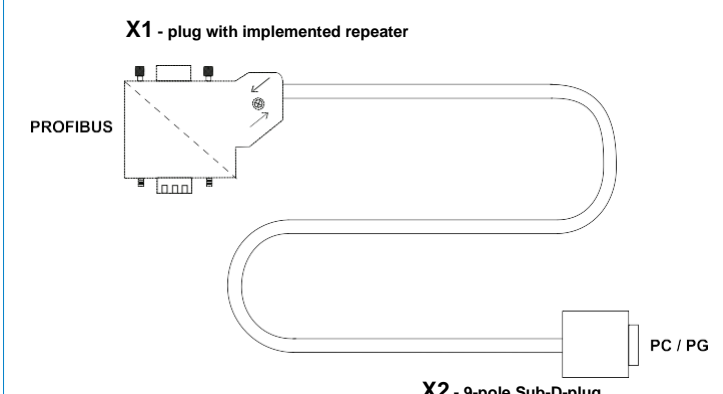

Engineering drawing

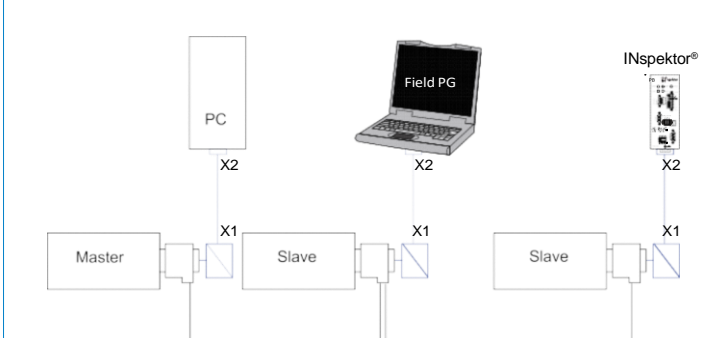

Example of use

### Active stub line ASTL

#### Function

The **ASTL** allows the feedback-free connection of a device as an active stub line. This is possible because of the integrated repeater function in the connector. The 5 V supply required for repeater operation shall be made available through the pin 5 (GND) and the pin 6 (+5 V) of the contacted 9-pin sub-D socket. It can be basically assumed that all slaves of the PROFIBUS norms support the relevant pin assignment. It can be basically assumed that all slaves of the PROFIBUS norms support the relevant pin assignment.

#### Connection

- 9-pin sub-D plug with integrated repeater (X1 cable outlet axial)
- 9-pin sub-D plug (X2 outlet axial 35°)

#### Electrical parameters

- Baud rate: 9,6 kbps to 12 Mbps
- Supply voltage: 4.75 to 5.25 VDC  
has to be provided by each PROFIBUS user (Pin 5 GND, Pin 6 +5V)

#### Design

- Weight: approx. 250 g
- Length: 3 m and 10 m

#### Ambient conditions

- Operating temperature: 0 °C to +60 °C
- Transport / storage temperature: -20 °C to +60 °C
- Industrial protection: P20
- Relative humidity: max. 75 % (non-condensing)

#### Pin assignment

Connector X1, connection measuring (repeater function)

Pin	Function	Note
1	not used	
2	M24	connects to X2 Pin 2
3	B	RS 485 data
4	not used	
5	GND	connects to X2 Pin 5
6	VCC	supply voltage +5V
7	P24	connects to X2 Pin 7
8	A	RS 485 data reversed
9	not used	

Connector X2, connection slave

Pin	Function	Note
1	not used	
2	M24	connects to X1 Pin 2
3	B	RS 485 data
4	R I S - AS	directional control from slave
5	GND	connects to X1 Pin 5
6	not used	
7	P24	connects to X1 Pin 7
8	A	RS 485 data reversed
9	not used	

Ordering details	Art. No.
Active stub line ASTL	110040005



ASTL

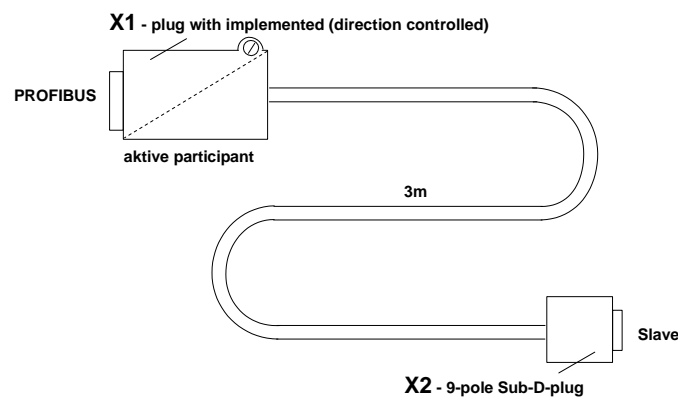

Engineering drawing

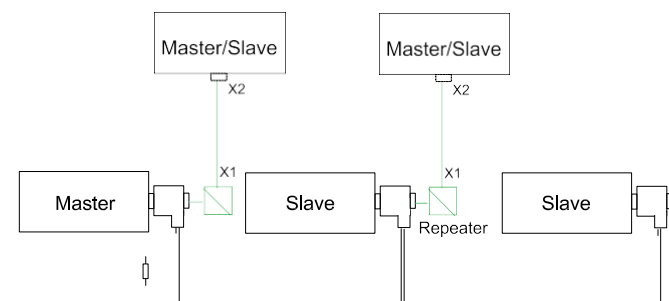

Example of use

### Diagnostic connector PG/90° screw terminal

#### Function

The PG / Service interface serves as feedback-free measuring point for measurements with PROFtest II / PROFI-TM Professional / PB-INSPEKTOR® and can also be used as programming interface. The plug is completely shielded by the metal-coated casing. The plug for the terminating resistor that is accessible from outside, disconnects the outgoing segment when being in ON position. The integrated three LEDs are used for the quick diagnosis of the bus status.

#### Bus connection

- 9-pin sub-D interface
- Screw terminal connection
- 90° cable outlet

#### Electrical parameters

- Terminating resistor: integrated, can be switched with a sliding switch from outside
- Baud rate: 9.6 kbps to 12 Mbps
- Supply voltage: 4.75 to 5.25 VDC  
has to be provided by each PROFIBUS user (Pin 5 GND, Pin 6 +5V)
- Current drain: 35 mA
- Diagnostic display through LED status

#### Ambient conditions

- Operating temperature: 0 °C to +60 °C
- Transport / storage temperature: -25 °C to +80 °C
- Relative humidity: max. 75 % at a temperature of +25 °C
- Industrial protection: IP20

#### Design

- Dimensions (H x W x D): 64 x 17 x 40 mm
- Interface: 9-pin sub-D
- Weight: approx. 40 g
- Casing: plastic material metallized

#### Status display for diagnostic function

- TxD-LED (blue - static) - Active device „OK“
- (green - flashing) - Communication „OK“
- „R“-LED (orange - flashing) - Terminating resistors active bus termination „OK“

#### CE mark

Plugs are passive components and are not subject to the CE mark system pursuant to EU Directives.

Ordering details	Art. No.
Diagnostic connector PG/90° screw terminal	110050009



Diagnostic connector PG/90° screw terminal

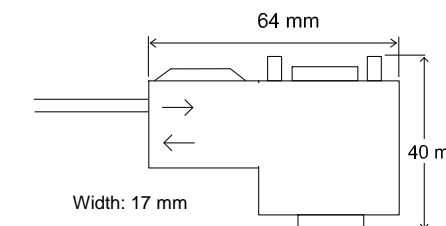

Engineering drawing

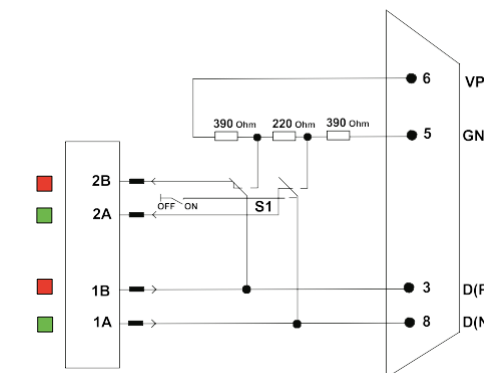

Functional diagram

### Diagnostic connector PG/90° Fast Connect

#### Function

The PG / Service interface serves as feedback-free measuring point for measurements with PROFtest II / PROFI-TM Professional / PB-INspektor® and can also be used as programming interface. The plug is completely shielded by the metal-coated casing. The plug for the terminating resistor that is accessible from outside, disconnects the outgoing segment when being in ON position. The design meets the Fast Connect requirement.

The integrated 4 LEDs (Power, TxD, Termination, Error) allow a quick diagnosis of the bus status. With the Error LED, for example reflections and missing terminating resistors are signalled.

#### Bus connection

- 9-pin sub-D interface
- Insulation piercing terminal (suitable for Fast Connect cable)
- 90° cable outlet

#### Electrical parameters

- Terminating resistor: integrated, can be switched with a sliding switch from outside
- Baud rate: 9.6 kbps to 12 Mbps
- Supply voltage: 4.75 to 5.25 VDC has to be provided by each PROFIBUS user (Pin 5 GND, Pin 6 +5V)
- Current drain: max. 30 mA
- Diagnostic display through LED status

#### Ambient conditions

- Operating temperature: -20 °C to +75 °C
- Industrial protection: IP20

#### Design

- Dimensions (H x W x D): 66 x 16 x 40 mm
- Interface: 9-pin sub-D
- Weight: approx. 80 g
- Casing: zinc die cast
- Max. fastening torque: 0,4 Nm

#### Status display for diagnostic function

- PWR-LED (green) - Voltage supply - 5 V „OK“
- TxD-LED (green) - Bus communication „OK“ (flashing)
- Term.-LED (green) - Terminating resistors active - bus termination „OK“  
terminating resistors defective (flashing)
- ERR-LED (yellow) - „OFF“ bus status „OK“  
„flashing“-fault!  
(reflection or no termination)



Diagnostic connector PG/90° Fast Connect

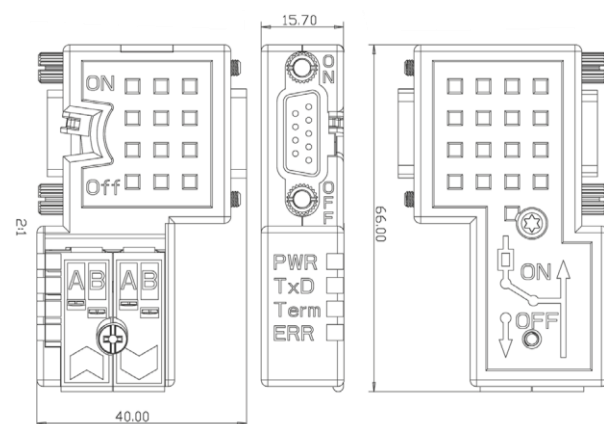

Engineering drawing

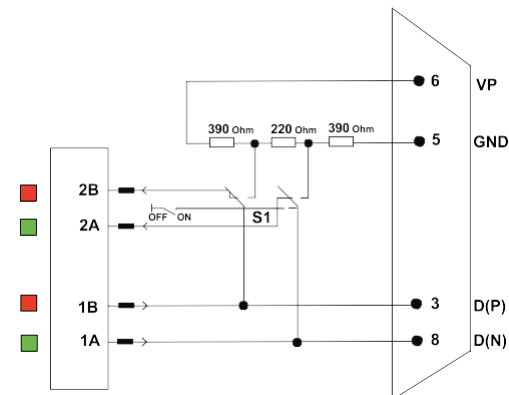

Functional diagram

Ordering details	Art. No.
Diagnostic connector PG/90° Fast Connect	110050006

#### CE mark

Plugs are passive components and are not subject to the CE mark system pursuant to EU Directives.

### Diagnosestecker PG/45° Fast Connect

#### Function

The PG / Service interface serves as feedback-free measuring point for measurements with PROFtest II / PROFI-TM Professional / PB-INspektor® and can also be used as programming interface. The plug is completely shielded by the metal-coated casing.

The plug for the terminating resistor that is accessible from outside, disconnects the outgoing segment when being in ON position. The design meets the Fast Connect requirement.

The integrated 4 LEDs (Power, TxD, Termination, Error) serve for a quick diagnosis of the bus status. With the Error LED, for example reflections and missing terminating resistors are signalled. Because of the very space-saving routing of the PROFIBUS line (45° cable outlet) this connector can also be used in densely structured control cabinets.

#### Bus connection

- 9-pin sub-D interface
- Insulation piercing terminal (suitable for Fast Connect cable)
- 45° cable outlet

#### Electrical parameters

- Terminating resistor: integrated, can be switched with a sliding switch from outside
- Baud rate: 9.6 kbps to 12 Mbps
- Supply voltage: 4.75 to 5.25 VDC has to be provided by each PROFIBUS user (Pin 5 GND, Pin 6 +5V)
- Current drain: max. 30 mA
- Diagnostic display through LED status

#### Ambient conditions

- Operating temperature: -20 °C to +75 °C
- Industrial protection: IP20

#### Design

- Dimensions (H x W x D): 61 x 16 x 52 mm
- Interface: 9-pin sub-D
- Weight: approx. 80 g
- Casing: zinc die cast
- Max. fastening torque: 0,4 Nm

#### Status display for diagnostic function

- PWR-LED (green) - Voltage supply - 5 V „OK“
- TxD-LED (green) - Bus communication „OK“ (flashing)
- Term.-LED (green) - Terminating resistors active - bus termination „OK“  
terminating resistors defective (flashing)
- ERR-LED (yellow) - „OFF“ bus status „OK“  
„flashing“-fault!  
(reflection or no termination)

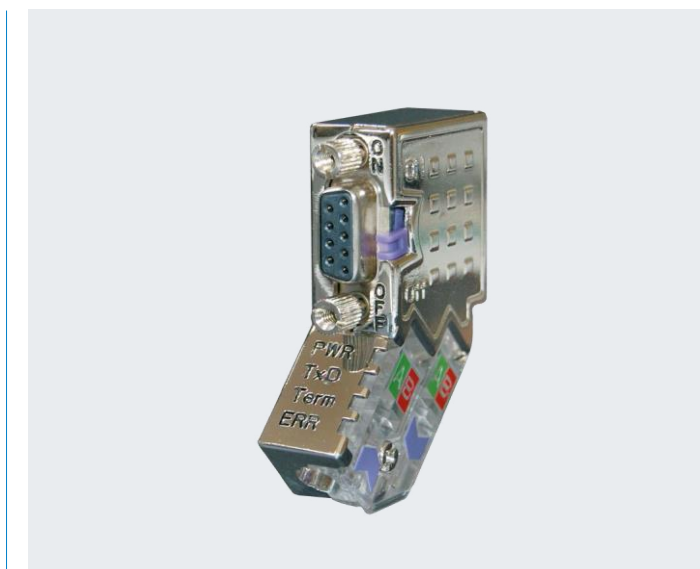

Diagnostic connector PG/45° Fast Connect

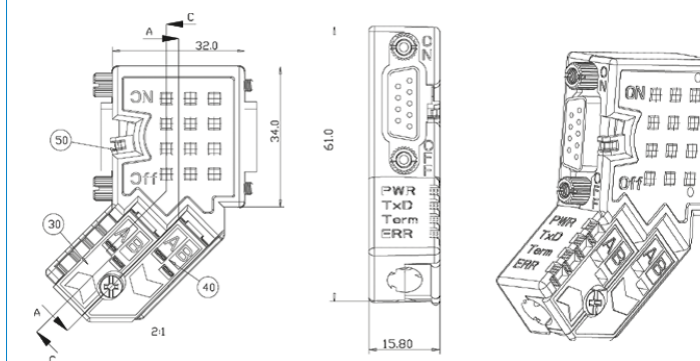

Engineering drawing

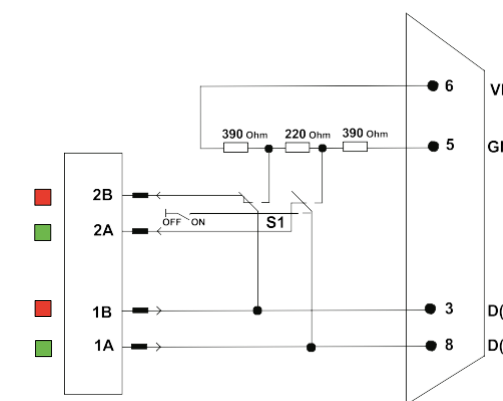

Functional diagram

Ordering details	Art. No.
Diagnostic connector PG/45° Fast Connect	110050007

#### CE mark

Plugs are passive components and are not subject to the CE mark system pursuant to EU Directives.

### Diagnostic connector axial Fast Connect

#### Function

The PG / Service interface serves as feedback-free measuring point for measurements with PROFtest II / PROFI-TM Professional / PB-INspektor® and can also be used as programming interface. The plug is completely shielded by the metal-coated casing. The plug for the terminating resistor that is accessible from outside, disconnects the outgoing segment when being in ON position. The design meets the Fast Connect requirement. The integrated 4 LEDs (Power, TxD, Termination, Error) serve for a quick diagnosis of the bus status. With the Error LED, for example reflections and missing terminating resistors are signalled.

#### Bus connection

- 9-pin sub-D interface
- Insulation piercing terminal (suitable for Fast Connect cable)
- Axial cable outlet

#### Electrical parameters

- Terminating resistor: integrated, can be switched with a sliding switch from outside
- Baud rate: 9.6 kbps to 12 Mbps
- Supply voltage: 4.75 to 5.25 VDC has to be provided by each PROFIBUS user (Pin 5 GND, Pin 6 +5V)
- Current drain: max. 30 mA
- Diagnostic display through LED status

#### Ambient conditions

- Operating temperature: -20 °C to +75 °C
- Industrial protection: IP20

#### Design

- Dimensions (H x W x D): 34 x 15,8 x 64 mm
- Interface: 9-pin sub-D
- Weight: approx. 80 g
- Casing: zinc die cast
- Max. fastening torque: 0,4 Nm

#### Status display for diagnostic function

- PWR-LED (green) - Voltage supply - 5 V „OK“
- TxD-LED (green) - Bus communication „OK“ (flashing)
- Term.-LED (green) - Terminating resistors active - bus termination „OK“  
terminating resistors defective (flashing)
- ERR-LED (yellow) - „OFF“ bus status „OK“  
„flashing“-fault!  
(reflection or no termination)

#### CE mark

Plugs are passive components and are not subject to the CE mark system pursuant to EU Directives.

Ordering details	Art. No.
Diagnosestecker axial Fast Connect	110050008



Diagnostic connector axial Fast Connect

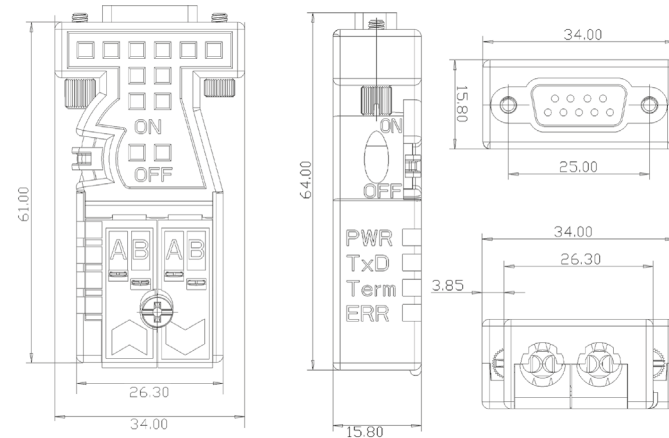

Engineering drawing

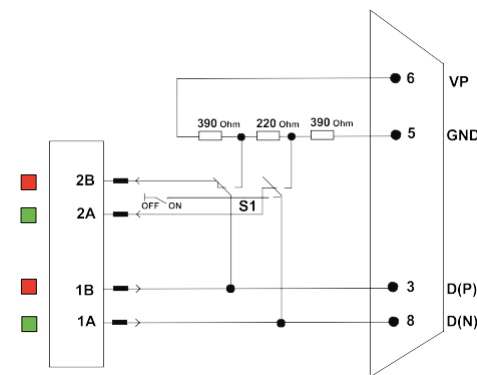

Functional diagram

### Connector PG/90° Fast Connect

#### Function

The PG / Service interface serves as feedback-free measuring point for measurements with PROFtest II / PROFI-TM Professional / PB-INspektor® and can also be used as programming interface. The plug is completely shielded by the metal-coated casing. The design meets the Fast Connect requirement. The plug for the terminating resistor that is accessible from outside, disconnects the outgoing segment when being in ON position. The design meets the Fast Connect requirement.

#### Bus connection

- 9-pin sub-D interface
- Insulation piercing terminal (suitable for „Fast Connect“ cable)
- 90° cable outlet

#### Electrical parameters

- Terminating resistor: integrated, can be switched with a sliding switch from outside
- Baud rate: 9.6 kbps to 12 Mbps
- Supply voltage: 4.75 to 5.25 VDC has to be provided by each PROFIBUS user (Pin 5 GND, Pin 6 +5V)
- Current drain: 12,5 mA

#### Ambient conditions

- Operating temperature: -20 °C to +75 °C
- Transport / storage temperature: -25 °C to +80 °C
- Industrial protection: IP20

#### Design

- Dimensions (H x W x D): 65 x 16 x 41 mm
- Interface: 9-pin sub-D
- Weight: approx. 80 g
- Casing: zinc die cast

#### CE mark

Plugs are passive components and are not subject to the CE mark system pursuant to EU Directives.

Ordering details	Art. No.
Connector PG/90° Fast Connect	110050010



Stecker PG/90° Fast Connect

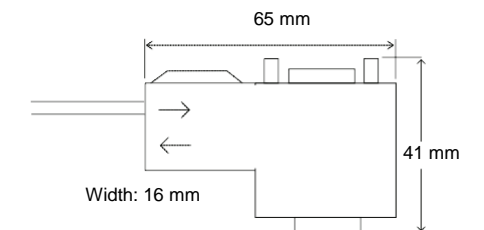

Engineering drawing

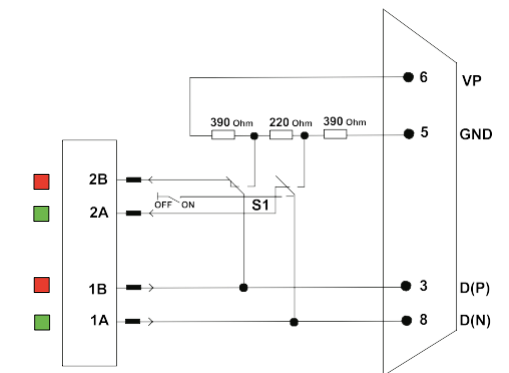

Functional diagram

### Connector PG/90° screw terminal

#### Function

The PG / Service interface serves as feedback-free measuring point for measurements with PROFtest II / PROFI-TM Professional / PB-INspektor® and can also be used as programming interface. The plug is completely shielded by the metal-coated casing.

The plug for the terminating resistor that is accessible from outside, disconnects the outgoing segment when being in ON position. When using the screw terminal all commercially available line types can be connected, so the plug can be used variously.

#### Bus connection

- 9-pin sub-D interface
- Screw terminal connection
- 90° cable outlet

#### Electrical parameters

- Terminating resistor: integrated, can be switched with a sliding switch from outside
- Baud rate: 9.6 kbps to 12 Mbps
- Supply voltage: 4.75 to 5.25 VDC  
has to be provided by each PROFIBUS user (Pin 5 GND, Pin 6 +5V)
- Current drain: 12,5 mA

#### Ambient conditions

- Operating temperature: 0 °C to +60 °C
- Transport / storage temperature: -25 °C to +80 °C
- Relative humidity: max. 75 % at a temperature of +25 °C
- Industrial protection: IP20

#### Design

- Dimensions (H x W x D): 64 x 17 x 40 mm
- Interface: 9-pin sub-D
- Weight: approx. 40 g
- Casing: plastic material metallized

#### CE mark

Plugs are passive components and are not subject to the CE mark system pursuant to EU Directives.



Connector PG/90° screw terminal

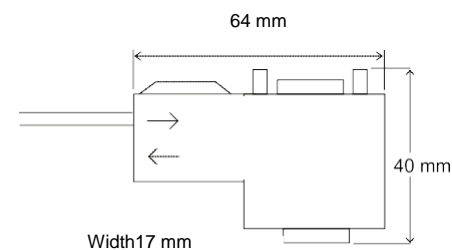

Engineering drawing

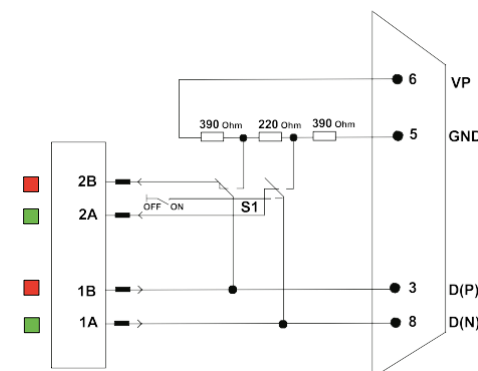

Functional diagram

Ordering details	Art. No.
Connector PG/90° screw terminal	110050002

### Connector PG/35° screw terminal

#### Function

The PG / Service interface serves as feedback-free measuring point for measurements with PROFtest II / PROFI-TM Professional / PB-INspektor® and can also be used as programming interface. The plug is completely shielded by the metal-coated casing.

The plug for the terminating resistor that is accessible from outside, disconnects the outgoing segment when being in ON position. When using the screw terminal all commercially available line types can be connected so the plug can be used variously.

#### Bus connection

- 9-pin sub-D interface
- Screw terminal connection
- 35° cable outlet

#### Electrical parameters

- Terminating resistor: integrated, can be switched with a sliding switch from outside
- Baud rate: 9.6 kbps to 12 Mbps
- Supply voltage: 4.75 to 5.25 VDC  
has to be provided by each PROFIBUS user (Pin 5 GND, Pin 6 +5V)

#### Ambient conditions

- Operating temperature: 0 °C to +60 °C
- Transport / storage temperature: -25 °C to +85 °C
- Relative humidity: max. 75 % at a temperature of +25 °C
- Industrial protection: IP20

#### Design

- Dimensions (H x W x D): 54 x 17 x 40 mm
- Interface: 9-pin sub-D
- Weight: approx. 35 g
- Casing: plastic material metallized

#### CE mark

Plugs are passive components and are not subject to the CE mark system pursuant to EU Directives.



Connector PG/35° screw terminal

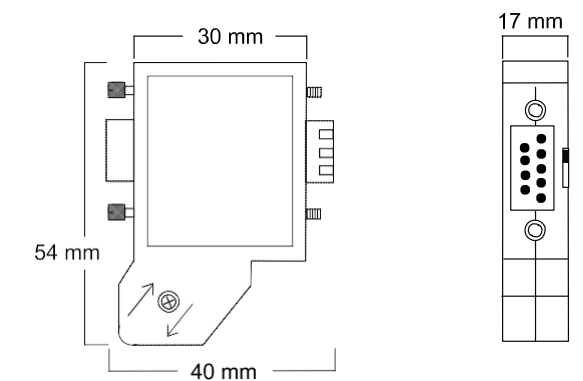

Engineering drawing

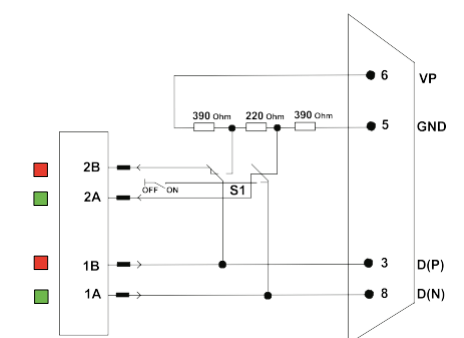

Functional diagram

Ordering details	Art. No.
Connector PG/35° screw terminal	110050004



### Connector axial screw terminal

**Function**

The axial fieldbus connector is used to connect a PROFIBUS device with a PROFIBUS line. The plug is shielded by a metal housing. The plug for the terminating resistor that is accessible from outside, disconnects the outgoing segment when being in ON position. When using the screw terminal all commercially available line types can be connected.

**Bus connection**

- 9-pin sub-D interface
- Screw terminal connection
- Axial cable outlet

**Electrical parameters**

- Terminating resistor: integrated, can be switched with a sliding switch from outside
- Baud rate: 9.6 kbps to 12 Mbps
- Supply voltage: 4.75 to 5.25 VDC has to be provided by each PROFIBUS user (Pin 5 GND, Pin 6 +5V)
- Current drain: 12,5 mA

**Ambient conditions**

- Operating temperature: 0 °C to +60 °C
- Transport / storage temperature: -25 °C to +75 °C
- Relative humidity: max. 75 % at a temperature of +25 °C
- Industrial protection: IP20

**Design**

- Dimensions (H x W x D): 41 x 17 x 67 mm
- Interface: 9-pin sub-D
- Weight: approx. 30 g
- Casing: plastic material metallized

**CE mark**

Plugs are passive components and are not subject to the CE mark system pursuant to EU Directives.



Connector axial screw terminal

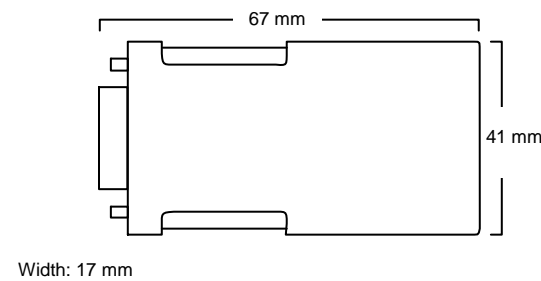

Engineering drawing

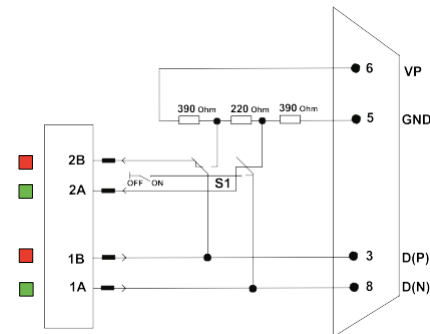

Functional diagram

Ordering details	Art. No.
Connector axial screw terminal	110050005

### Connector M12 with PG 90° compact and standard

**Function**

The bus connector is specifically designed for a simple, fast and safe plug & play connection of maximum 40 PROFIBUS devices in PROFIBUS systems up to 2 Mbit/s. The front-end standardized PROFIBUS sub-miniature connector is plugged to the PB device. The bus connector is connected with the bus network by precut M12 PROFIBUS cables. For shielding and safe use even under rougher conditions it has been provided with an all-metal housing. The influences of problematic bus components and the influences of measuring and test devices are largely compensated. For diagnostic or programming purposes the connector has a second sub-miniature interface. Its compact design allows an application under almost all conditions, in particular in narrow spaces.

**Bus connection**

- 9-pin sub-D interface
- M12 B-coded
- 90° cable outlet

**Electrical parameters**

- Bus termination: Bus termination resistors activated via external switch or via M12 terminating resistor
- Baud rate: 9,6 kbps to 12 Mbps

**Ambient conditions**

- Ambient temperature: -20 °C to +70 °C
- Permissible humidity: max. 75% at +25 °C, non-condensing
- Industrial protection: IP30

**Design**

- Dimensions (H x W x D)
  - compact: 58,8 x 16,8 x 45 mm
  - standard: 84,8 x 16,8 x 35,6 mm
- Interface: 9-pin sub-D
- Casing: Zinc alloy

**CE mark**

Plugs are passive components and are not subject to the CE mark system pursuant to EU Directives.



Connector M12 with PG 90° compact (left) and standard (right)

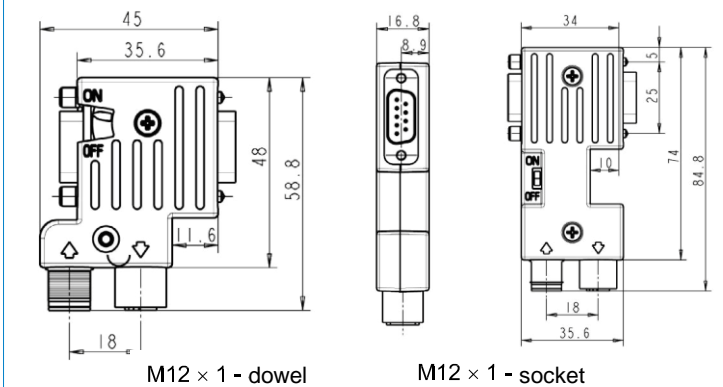

Fieldbus connection by M12 B-

Engineering drawing compact (left) and standard (right)

Ordering details	Art. No.
Connector M12 with PG 90° compact	110050016
Connector M12 with PG 90° standard	110050017

**Accessories**

M12 terminator socket	110050019
-----------------------	-----------

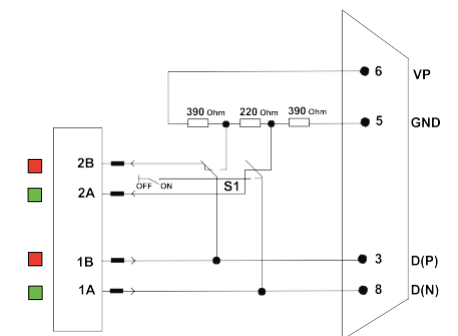

Functional diagram

### Connector M12 with PG 35° spezial

#### Function

The bus connector is specifically designed for a simple, fast and safe plug & play connection of maximum 40 PROFIBUS devices in PROFIBUS systems up to 2 Mbps. The front-end standardized PROFIBUS sub-miniature connector is plugged to the PB device. The special design with the 35° cable outlet makes it particularly suitable for installation in places where two interfaces are arranged on top of each other. The bus connector is connected with the bus network by pre-cut M12 PROFIBUS cables.

For shielding and safe use even under rougher conditions it has been provided with an all-metal housing. The influences of problematic bus components and the influences of measuring and test devices are largely compensated.

For diagnostic or programming purposes the connector has a second sub-miniature interface.

#### Bus connection

- 9-pin sub-D interface
- M12 B-coded
- 35° cable outlet

#### Electrical parameters

- Bus termination: Bus termination resistors activated via external switch or via M12 terminating resistor
- Baud rate: 9,6 kbps to 12 Mbps

#### Ambient conditions

- Ambient temperature: -20 °C to +70 °C
- Permissible humidity: max. 75% at +25 °C, non-condensing
- Industrial protection: IP30

#### Design

- Dimensions (H x W x D): 67,7 x 16,8 x 45 mm
- Interface: 9-pin sub-D
- Casing: Zinc alloy

#### CE mark

Plugs are passive components and are not subject to the CE mark system pursuant to EU Directives.

Ordering details	Art. No.
Connector M12 with PG 35° spezial	110050015

Accessories	Art. No.
M12 terminator socket	110050019



Connector M12 with PG 35° spezial

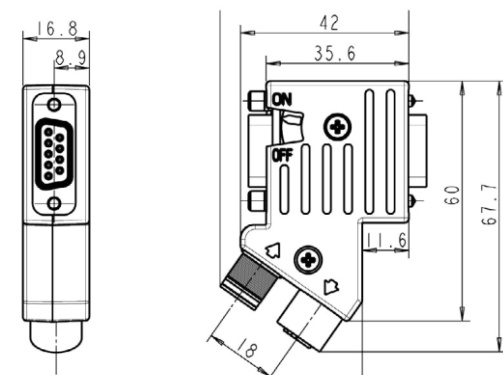

M12 x 1 - dowel M12 x 1 - socket



Fieldbus connection by M12 B-encoded

Engineering drawing

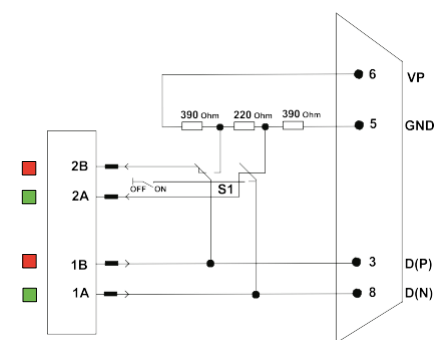

Functional diagram

### Connector M12 without PG 180° axial

#### Function

The bus connector is specifically designed for a simple, fast and safe plug & play connection of maximum 40 PROFIBUS devices in PROFIBUS systems up to 2 Mbit/s. The front-end standardized PROFIBUS sub-miniature connector is plugged to the PB device. The axial design with the 180° cable outlet makes it particularly suitable for installation in places where two interfaces are arranged on top of each other. The bus connector is connected with the bus network by pre-cut M12 PROFIBUS cables.

For shielding and safe use even under rougher conditions it has been provided with an all-metal housing. The influences of problematic bus components and the influences of measuring and test devices are largely compensated.

#### Bus connection

- 9-pin sub-D interface
- M12 B-coded
- Axial cable outlet

#### Electrical parameters

- Bus termination: Bus termination resistors activated via external switch or via M12 terminating resistor
- Baud rate: 9,6 kbps to 12 Mbps

#### Ambient conditions

- Ambient temperature: -20 °C to +70 °C
- Permissible humidity: max. 75% at +25 °C, non-condensing
- Industrial protection: IP30

#### Design

- Dimensions (H x W x D): 31 x 14,8 x 76,8 mm
- Interface: 9-pin sub-D
- Casing: Zinc alloy

#### CE mark

Plugs are passive components and are not subject to the CE mark system pursuant to EU Directives.

Ordering details	Art. No.
Connector M12 without PG 180° axial	110050018

Accessories	Art. No.
M12 terminator socket	110050019



Connector M12 without PG 180° axial

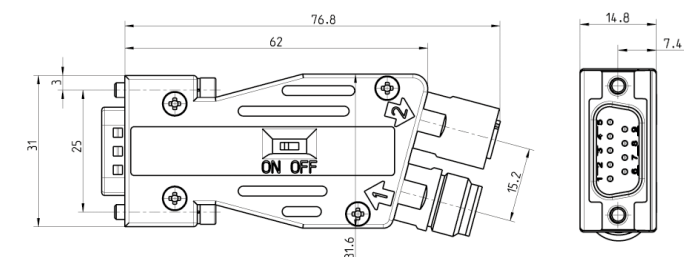

M12 x 1 - dowel M12 x 1 - socket



Fieldbus connection by M12 B-encoded

Engineering drawing

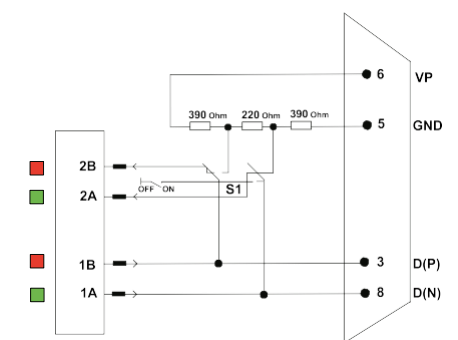

Functional diagram

### M12 round plug connector FC Plug PRO self-made-up (B-coded)

#### Application / Installation

PROFIBUS machine installation without control cabinets in protection type IP65/67 demand compact sturdy M12 plug connectors. The PROFIBUS Fast Connect M12 Plugs (B-coded) ensure simple, fast and reliable installation due to their integral insulation-piercing design. The 4-pole design with integral large surface area shield contacting via the metal housing means full compliance with the current specification of the PNO (PROFIBUS user organisation) installation guidelines.

The PROFIBUS Fast Connect Stripping Tool to prepare the end of the cable (strip the sheath and shield on the cable in one operation) ensures easy handling and fast, error-free contacting of the cable on the plug connectors. Since the plug connectors consist of just two housing parts, they can be assembled easily even in difficult conditions. The side handling surfaces allow the use of an open-ended spanner and make screwing the plug halves easy during the finishing operation.

#### Bus connection

- M12 (B-coded)
- Fast Connect
- Axial outgoing cable
- Transfer speed: 9.6 kbps to 12 Mbps

#### Electrical values

- Rated current / Contact: 4 A (IEC 60512- 3)
- Rated voltage / Contact: 30 VAC, 36 VDC (VDC 0110)

#### Ambient conditions

- Operating temperature: -40°C to +85°C
- Protection type: IP65/67 when connected and screwed (DIN VDE 0470)

#### Constructive design

- Weight: Straight: 40 g
- Housing: Metal
- Dimensions (WxHxD): 19 x 19 x 73 mm
- Contact surface: Brass alloy (CuSnZn)
- Connection cross-section: max. 0.75 mm<sup>2</sup>

#### CE mark / UL approval

Plugs are passive components and are not subject to the CE mark system pursuant to EU Directives.

The M12 round plug connector FC Plug PRO (B-coded) is a coordinated system of PROFIBUS Fast Connect plug connectors and an extensive range of Fast Connect cables with the appropriate UL approvals.

Ordering details	Art. No.
M12 round plug connector FC Plug PRO (B-coded) connector	110050024
M12 round plug connector FC Plug PRO (B-coded) socket	110050025



M12 round plug connector FC Plug PRO (B-coded)



Sample application (side view)



Sample application (view from above)

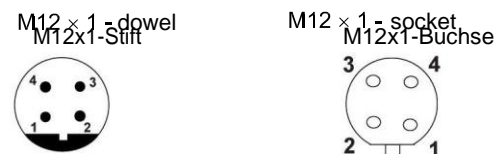

- Pin 1: Not used
- Pin 2: A cable (green)
- Pin 3: Not used
- Pin 4: B cable (red)

Pin assignment

### M12 round plug connector ready made-up (B-coded)

#### Function

Ready made-up fieldbus lines ensure easy and safe wiring of the fieldbus components. Time-consuming single wiring and possible bus problems due to distortions or a lack of allover screening are thus things of the past. The lines are available with sprayed-on plug connectors on one or either side. The preferential lengths of one-sided connections is 10 m and 0.3 m and 0.6 m for the double-sided types.

#### Electrical parameters

- Surge impedance: at 20 MHz: 150 Ohm ±15 Ohm
- Rated voltage: 4,0 A
- Line resistance: ≤ 93,3 Ohm / km

#### Ambient conditions

- Operating temperature: -40 °C to +70 °C
- Industrial Protection: IP67 and NEMA 1, 3, 4, 6, 13

#### Design

- Bus connection: M12x1, inversely encoded in accordance with PNO guidelines
- Casing: unpcast polyurethane, creepage and clearance in air acc. to VDE c110, size C (250 V 1c / 300 VDC) gold-plated brass nickel-plated brass
- Contact: gold-plated brass
- Cap nut: nickel-plated brass

Ordering details	Art. No.
<b>Cable M12 (B-coded), ready made-up on one end</b>	
10 meter (socket)	110070012
10 meter (connector)	110070013
<b>Cable M12 (B-coded), ready made-up on both ends</b>	
0,3 meter (socket, connector)	110070007
0,6 meter (socket, connector)	110070011

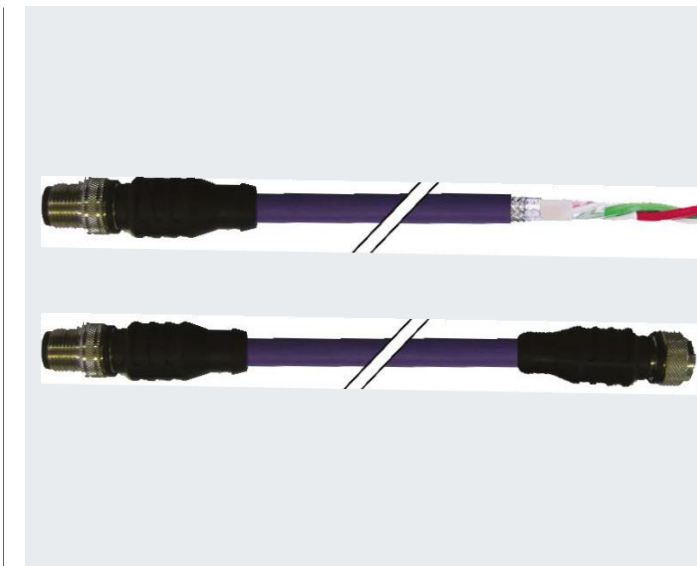

Cable ready made-up M12 (B-coded)

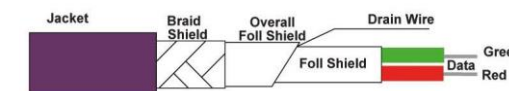

Engineering drawing

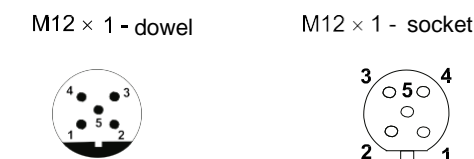

- Pin 1: Not used
- Pin 2: A cable (green)
- Pin 3: Not used
- Pin 4: B cable (red)
- Pin 5: Not used

Pin assignment

### M12 terminator socket (B-coded)

#### Function

In PROFIBUS networks require the bus termination with termination resistors according to the PROFIBUS specification for the first bus participant on the input side and for the last bus participant on the output side. One solution, even under harsh conditions, for PROFIBUS components with M12 interfaces is the socket-type **M12 terminator** for the cable outlet. Shielding and a safe use even under rough conditions are ensured by an impact- and shock-resistant all-metal housing.

#### Bus connection

- M12 (B-coded)

#### Electrical parameters

- Current rating: 4 A
- Operation voltage: 32 VDC

#### Ambient conditions

- Temperature range: -40 °C to +85 °C
- Industrial protection: IP67 (nur only screw-locked)

#### Design

- Dimensions (Length x cross-section): 53,2 mm x 16 mm<sup>2</sup>
- Case: metal
- Torque: 0,8-1 Nm (max.2Nm)
- Wrench size: SW 13

#### CE mark

Plugs are passive components and are not subject to the CE mark system pursuant to EU Directives.



M12 terminator socket

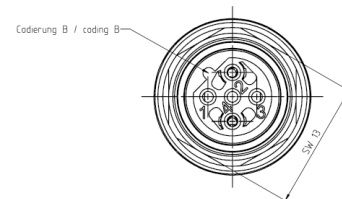
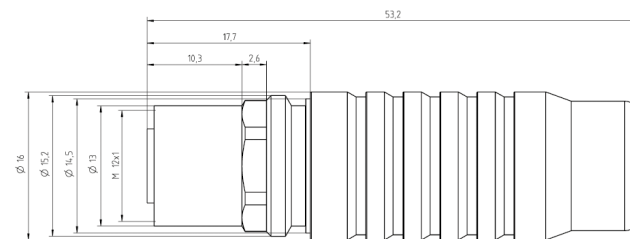

Engineering drawing

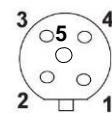

- Pin 1: Not used
- Pin 2: A cable (green)
- Pin 3: Not used
- Pin 4: B cable (red)
- Pin 5: Not used

Pin assignment

Ordering details	Art. No.
M12 terminator socket (B-coded)	110050019

### Built-in repeater DLP30

#### Function

The **built-in repeater DLP30** is a RS 485 repeater for feedback-free connection of a PROFIBUS slave as an active spur. The main field of application of this product is instrument manufacture. It may happen that the internal PROFIBUS interfacing has to be installed at a certain distance from the PROFIBUS module location proper. Often the connection is rendered through a line section which from a length of >10 cm as passive spur line has a negative impact on the data communication quality. If several of these devices are in one segment, the lengths of the internal spurs must be added together. Although according to PNO the sum of spur lines in the PROFIBUS of 6.6 m is admissible with a Baud rate of up to 1.5 Mbps, passive spur lines of any length should not be used for the sake of a long-term, safe and reliable data communication.

#### Installation recommendation

The external PROFIBUS connection is rendered through a relevant casing cut-out for a 9-pin sub-D connector. Should an additional mechanical protection be needed, a suitable guard plate can be provided.

#### Bus connection

- 9-pin standard PROFIBUS connector
- The slave is connected via a 10-pin ribbon cable.
- Total length 2.0 m must not be exceeded.
- A shielded type is recommended from a length of 0.3 m.
- The internal connecting cable is not included in the scope of supply.

Upon request delivery/assembly will be customized (line lengths and connector design).

#### Electrical parameters

- +5 V and RTS signal must be available at slave
- Baud rate: 9.6 kbps to 12 Mbps

#### Ambient conditions

- Operating temperature: 0 °C to +60 °C
- Transport / storage temperature: -20 °C to +60 °C
- Relative humidity: max. 75 % (non-condensing)
- Protective system: IP20

#### Testing

It is recommended to test the proper function after installation by measurements.

Ordering details	Art. No.
Built-in repeater DLP30	110030005

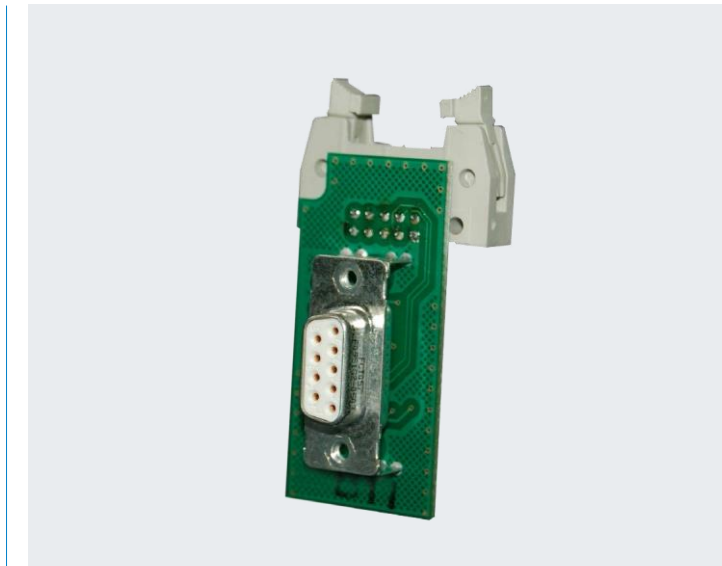

Built-in repeater DLP30

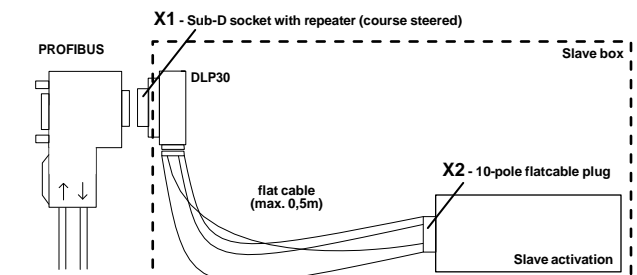

Engineering drawing

#### Connector X1 (sub-D), connection measuring (repeater function)

Pin	Function	Note
1	not used	
2	M24	connects to X2 Pin 3
3	B	RS-485 Daten
4	not used	
5	GND	connects to X2 Pin 9
6	VCC	supply voltage +5V
7	P24	connects to X2 Pin 4
8	A	RS-485 data reversed
9	not used	

#### Connector X2 (ribbon cable connector), connection slave

Pin	Function	Note
1	not used	
2	VCC	supply voltage +5V
3	M24	connects to X1 Pin 2
4	P24	connects to X1 Pin 7
5	B	RS-485 datan
6	A	RS-485 data reversed
7	RTS-AS	connects to X1 Pin 7
8	not used	
9	GND	connects to X2 Pin 5
10	not used	

Pin assignment

## INBLOX® Modular diagnostic repeater

### Function

The **Modular diagnostic repeater** of the INBLOX® series is based on a modular extensible repeater with up to maximally 25 isolated bus segments. In addition to the repeater function every bus outlet has a diagnostic function. Besides the known repeater function the bus diagnosis of all outlets is based on the logic and physical data traffic. The parameters in the form of field set triggers are repeat telegrams and restarts of devices or quality characteristics, edge steepness, level and glitches. Using the smart head module, E-head, these values can be set by the web interface and displayed as matrix.

### Module combinations

Depending on the head module selected in combination with the individual extension modules you can opt between a logic and a physical diagnosis. For alarms you can choose based on the degree of intelligence, a simple LED, a field contact through to a SNMP management solution. There are different proposals for combination.

- **Basic Line** (Basic Rep, DP Diag Rep),
- **Premium Line** (E-Kopf, DP Diag Rep) and
- **Comfort Line** (E-Kopf, Diag+ Rep)

are examples of how to combine depending on the required level of comfort and degree of intelligence of the modules. All modules can be combined with each other in different variations depending on the requirement.



Modular diagnostic repeater

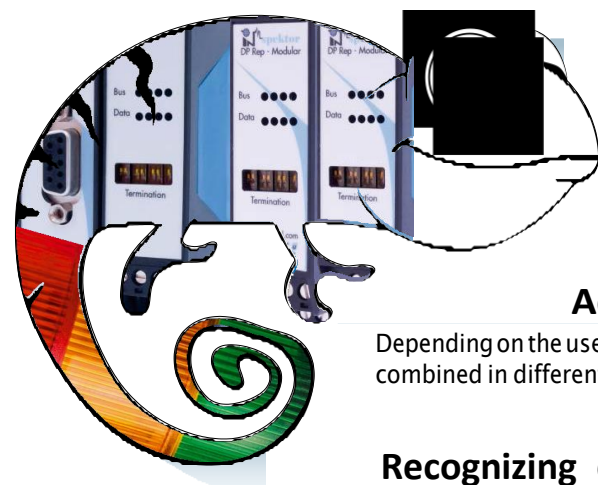

### Panoramic view

The smart Modular Diagnosis Repeater is integrated in automation systems and is versatile thanks to its modularity.

### Adaptability

Depending on the user's requirements all modules can be combined in different variants.

### Recognizing danger

Depending on the head module selected alarms are given via an LED signal per segment or switching contact and email resp.

Ordering details	Art. No.
DP Basic Rep	124060007
Ethernet head module (E-head)	124060000
Extension DP Diag+ Rep	124060010
Extension DP Diag Rep	124060009
Extension alarm module	124060006

## INBLOX® DP Basic Rep

### Function

The **DP Basic Rep** is the head module of a multiple repeater that can be extended by up to five extension modules. It has no higher intelligence and serves primarily as repeater with an extended diagnosis via LED.

The coming PROFIBUS has got a 9-pin D-subminiature connector. Four terminal connections provide for the PROFIBUS outlets and thus five segments can be built.

By the extension modules each having four segments it is possible to create up to 25 segments. The LEDs provide for a simple diagnosis.

### Technical data

- Voltage supply: 24 VDC ± 20 %
- Power supply: 0,3 A
- Connection: 9 pole sub-D – IN  
4 screw terminals – OUT  
(Assignment: shield / B / A / shield)
- Baud rate: 9,6 kbps to 12 Mbps

### General data

- Installation: 35 mm DIN top-hat rail
- Dimensions (H x W x D): 114,5 x 45,2 x 99 mm
- Protective system: IP20
- Operating temperature: 5 °C to 55 °C
- Storage temperature: -20 °C to 70 °C
- PROFIBUS-Types: DP, DP-V1, FMS, MPI
- Extension: DP Diag Rep (till 5 pieces)

### Terminal confi

#### PROFIBUS DP

Terminal connection for DP

Channel 2 | Channel 3  
2 B | 6 B  
3 A | 7 A  
1+4 shield | 5+8 shield

Channel 4 | Channel 5  
10 A | 14 A  
11 B | 15 B  
9+12 shield | 13+16 shield

Channel 1 sub-D socket

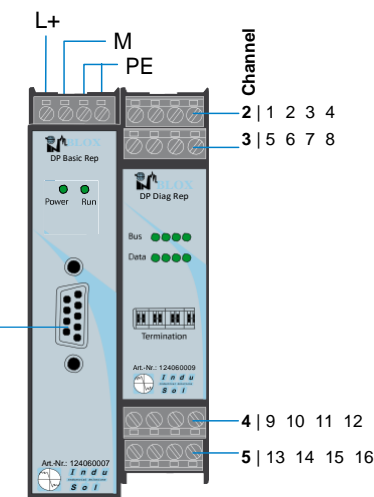

DP Basic Rep

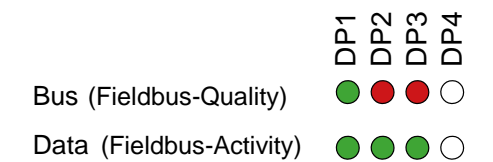

Fieldbus-LED Green: Everything o.k.

Data-LED Green: Data traffic exists

Power-LED Green: 24V connected

RUN-LED: BUS-LED for channel 1

BUS-LED red: Error detected f.e.

- Error telegrams,
- Repeat telegrams,
- Device failures,
- Diagnostic messages,
- Noise failure

### LED Diagnosis

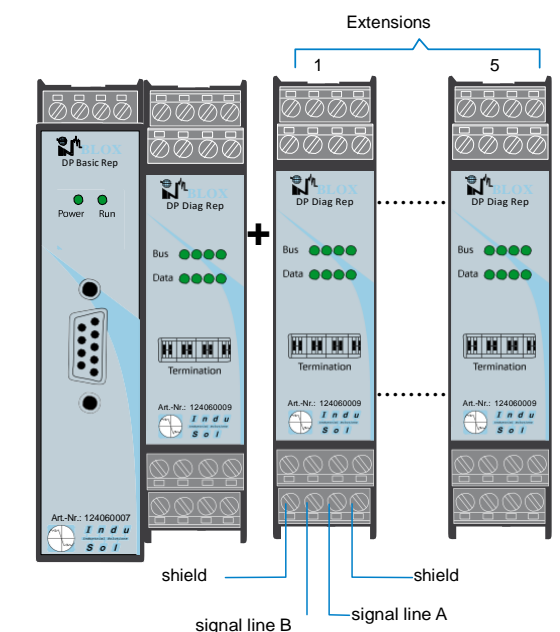

Sample confi

Ordering details	Art. No.
DP Basic Rep	124060007

### INBLOX® Ethernet head module

#### Function

The **Ethernet head module** is the basis of the premium and comfort version of the INBLOX® series. In addition to its 24 V supply voltage connection it has got a LAN connection for the integrated web server. The head is the core of the smart INBLOX® series and can be extended to max. 20 segments and fi segments resp. by Diag Rep modules and Diag+ Rep modules. An alarm module can be connected in place of a fi extension module. Event alarms are then given by switching contacts. The E-head is provided with an extended logic and alarms are shown on the web screen as known from the INspektor®. For every extension module a device matrix with certain colours for relevant events can be displayed and the alarms stored as snapshots (up to 100 per extension module). The head has different options to alert the user in case of network deterioration. It is possible to send an e-mail, an SNMP trap or the INBLOX® can be integrated in a network monitoring software, such as PROmanage®.

#### Technical data

- Voltage supply: 24 VDC
- Power supply: 0,3 A
- Connection: screw terminal for 24 V voltage supply  
LAN-Connection for Web interface
- Baud rate: 9,6 kbps to 12 Mbps
- Ethernet: 100 Mbps / 10 Mbps
- Baud rate: RJ45
- Connection: IPv4 via DHCP or manual
- Protocols: NTP-time synchronizing
- Time server:

#### General data

- Installation: 35 mm DIN top-hat rail
- Dimensions (H x W x D): 114,5 x 22,5 x 99 mm
- Protective system: IP20
- Operating temperature: 5 °C to 55 °C
- Storage temperature: -20 °C to 70 °C
- PROFIBUS-Typen: DP, DP-V1, FMS, MPI
- Extension: DP Diag Rep, DP Diag+ Rep, alarm module  
PA Diag+, DP-Master  
E-Mail  
SNMP-Trap  
SNMP-request with PROmanage®
- Automatic alarm:

#### LED assignment



**Power:** lights up green, if 24 V is connected. **Run:** blinks green at 1 Hz ,rate if everything is o.k.

#### Ordering details

Ethernet head module (E-head) **Art. No. 124060000**

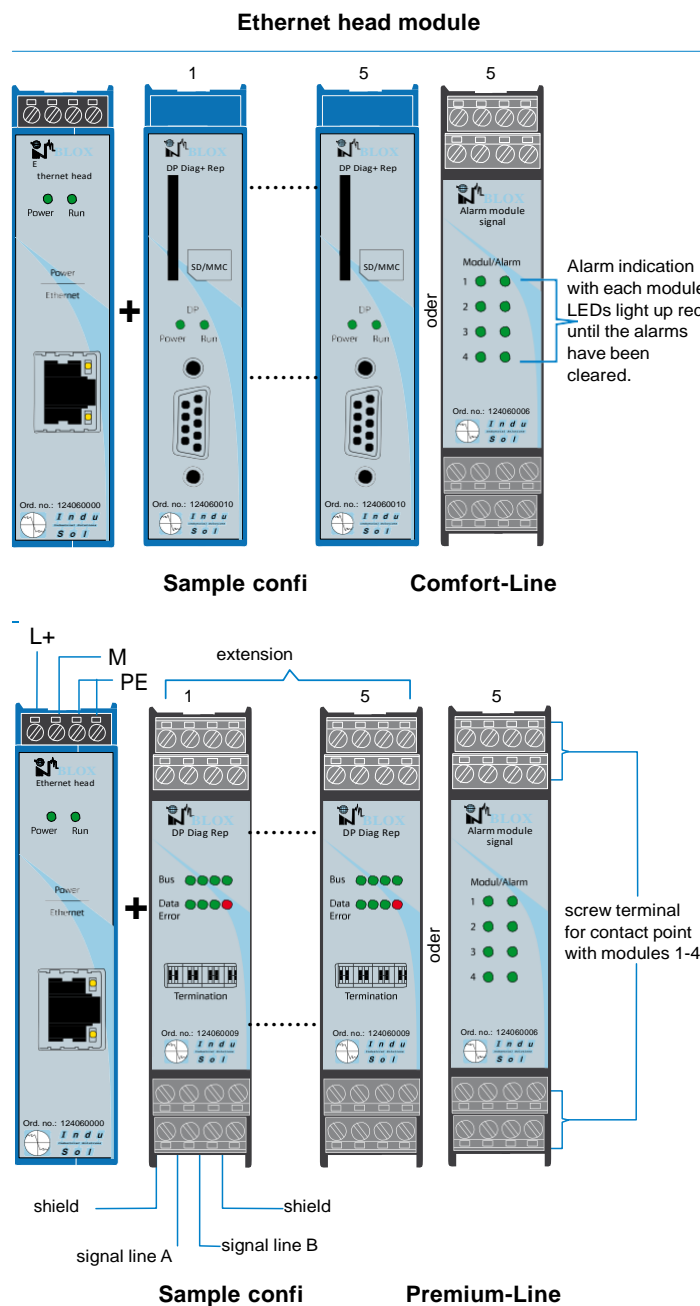

### INBLOX® Ethernet head module

#### Web interface



Main page: The module to be viewed can be selected, display of all modules installed

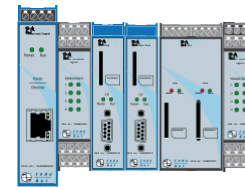
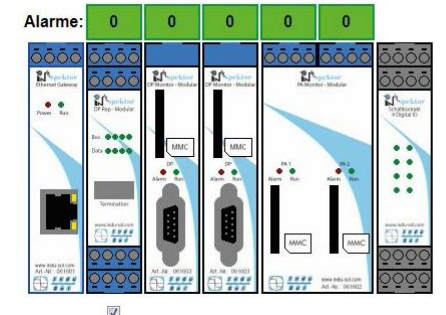

#### Node Overview

PB INspektor date/time	Current State	Last Cycle	History	0 Alarms
06/27/2013 10:11:27 AM	0	1 h	0	Clear data
Lost Nodes	0	0	0	Data protocol
Restart Nodes	0	0	0	Update rate (10s):
Internal Node Diagnosis	0	0	0	Baud rate: 6 MB/s
External Node Diagnosis	0	0	0	Device temperature: 42 C
Error telegrams	0	0	0	
Telegram retries per bus cycle	0	0	0	
Total telegram retries	0	0	0	
Network Condition in %	100	100	100	
Start of measurement	06/27/2013 10:11:25 AM	06/27/2013 09:17:25 AM	06/17/2013 03:17:25 PM	
Last SNMP request	(never requested)			

- Network
- Email
- SNMP
- Date/Time
- Password
- Firmware
- Restart
- System information

#### Main module



- Settings
- PB-Devices
- State Calculation

#### Overview Nodes

Node Overview	Events/Parameter	Node state								
History	Overview	not existant	Master ok	Master warning	Slave error	Slave ok	Slave warning	Slave error	present, not projected	not present
0	Device 0 Location 0	Device 1 Location 1	Device 2 Location 2 CPU Schulergeraum	Device 3 Location 3	Device 4 Location 4	Device 5 Location 5	Device 6 Location 6	Device 7 Location 7	Device 8 Location 8	Device 9 Location 9
1	Device 10 Location 10	Device 11 Location 11	Device 12 Location 12	Device 13 Location 13	Device 14 Location 14	Device 15 Location 15	Device 16 Location 16	Device 17 Location 17	Device 18 Location 18	Device 19 Location 19
2	Device 20 Location 20	Device 21 Location 21	Device 22 Location 22	Device 23 Location 23	Device 24 Location 24	Device 25 Location 25	Device 26 Location 26	Device 27 Location 27	Device 28 Location 28	Device 29 Location 29
3	Device 30 Location 30	Device 31 Location 31	Device 32 Location 32	Device 33 Location 33	Device 34 Location 34	Device 35 Location 35	Device 36 Location 36	Device 37 Location 37	Device 38 Location 38	Device 39 Location 39
4	Teilnehmer 40 Schulergeraum	Device 41 Location 41	Device 42 Location 42	Device 43 Location 43	Device 44 Location 44	Device 45 Location 45	Device 46 Location 46	Device 47 Location 47	Device 48 Location 48	Device 49 Location 49
5	Device 50 Location 50	Device 51 Location 51	Device 52 Location 52	Device 53 Location 53	Device 54 Location 54	Device 55 Location 55	Device 56 Location 56	Device 57 Location 57	Device 58 Location 58	Device 59 Location 59
6	Device 60 Location 60	Device 61 Location 61	Device 62 Location 62	Device 63 Location 63	Device 64 Location 64	Device 65 Location 65	Device 66 Location 66	Device 67 Location 67	Device 68 Location 68	Device 69 Location 69

snapshot list: Click the name and the PROFIBUS diagnosis Suite opens.

#### Snapshots

Create manual snapshot

Delete all snapshots

Download all as .zip

Display of a snapshot in the PROFIBUS diagnosis Suite

Nr.	Name	Date/Time
26	IS_00025.rpb	14.03.2013 11:58:47
25	IS_00023.rpb	14.03.2013 11:58:44
24	IS_00024.rpb	14.03.2013 11:58:44
23	IS_00022.rpb	14.03.2013 11:58:42
22	IS_00021.rpb	14.03.2013 11:58:41
21	IS_00020.rpb	14.03.2013 11:58:37
20	IS_00019.rpb	14.03.2013 11:58:28
19	IS_00018.rpb	14.03.2013 11:58:27
18	IS_00017.rpb	14.03.2013 11:58:19
17	IS_00016.rpb	14.03.2013 11:58:07

Nr.	Zeitstempel	Adresse	Protokoll	Primitive	Dienst	Daten
916	21:48:06.086812	2 -> 29	FDL	Request	FDL STATUS	
917	21:48:06.087064	2 -> 2	FDL	Request	IOKEN	
918	21:48:06.087112	2 -> 8	DP	Request	DATA EXCHANGE	
919	21:48:06.087264	2 -> 8	DP	Response	DATA EXCHANGE	00
920	21:48:06.087264	2 -> 32	DP	Request	DATA EXCHANGE	00 00
921	21:48:06.087352	2 -> 32	DP	Response	DATA EXCHANGE	01 00
922	21:48:06.087460	2.62 -> 16.60	DP	Request	DIAGNOSTIC	
923	21:48:06.087751	2 -> 30	FDL	Request	FDL STATUS	
924	21:48:06.088003	2 -> 2	FDL	Request	IOKEN	
925	21:48:06.088052	2 -> 8	DP	Request	DATA EXCHANGE	
Module diagnostic						
Module-number with upcoming diagnostic: 7						
Module status						
Slot 7: invalid Data, no module available						
931	21:48:06.088942	2 -> 2	FDL	Request	FDL STATUS	
932	21:48:06.088990	2 -> 8	DP	Request	DATA EXCHANGE	

### INBLOX® DP Diag+ Rep

#### Function

The DP Diag+ Rep extension is provided with a D-subminiature connector and can thus open a segment. It is simply connected to the head and is coupled with the backplane bus directly. It obviates the need of a separate voltage supply. Not only peripheral devices and devices can be connected to the segments but also other master systems. Up to five extension modules can be connected to every head. It is thus possible to create up to five segments per head module. The PROFIBUS can be converted from its original line topology to a star topology and spur lines designed without reservation. Each individual segment is monitored by the integrated diagnosis. The alarm LED displays errors diagnosed during monitoring. These DP Diag+ Rep modules require the E-head for design. Via the web interface the device matrix can be displayed and the relevant diagnoses (error telegrams repeat telegrams etc.) read out. The bus physics, too, is permanently monitored for the first time and can be displayed by a bar chart for the quality characteristics or an oscilloscope recording.

#### Technical data

- Voltage supply: 24 VDC with a backplane bus
- Power supply: 0,3 A with a backplane bus
- Connection: 9-pole sub-D PROFIBUS-connection
- Baud rate: 9,6 kbps to 12 Mbps

#### General data

- Installation: 35 mm DIN top-hat rail
- Dimensions (H x W x D): 114,5 x 22,5 x 99 mm
- Protective system: IP20
- Operating temperature: 5 °C to 55 °C
- Storage temperature: -20 °C to 70 °C
- PROFIBUS-types: DP, DP-V1, FMS, MPI
- Characteristics: card slot for SD/MMC memory cards

#### LED assignment



**Alarm:** signal lights red, when alarm is lying ahead



**Run:** lights up green, if everything is o.k.



DP Diag+ Rep

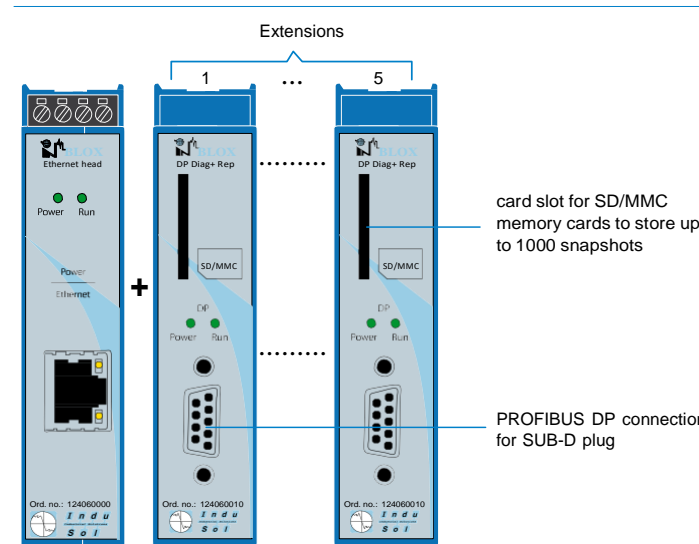

Sample confi

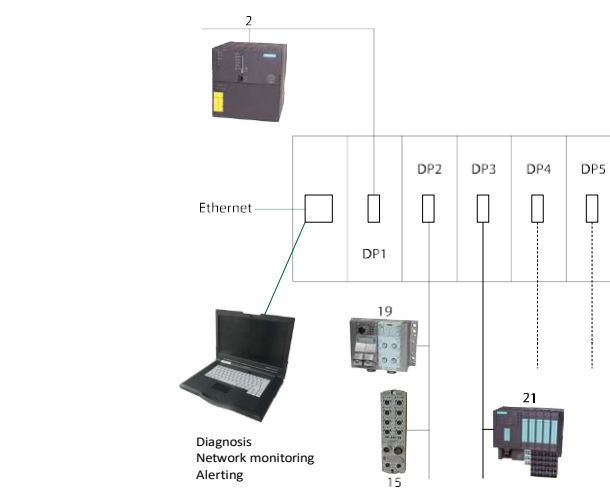

Practical example

Ordering details	Art. No.
Extension DP Diag+ Rep	124060010

### INBLOX® DP Diag+ Rep

#### Web interface

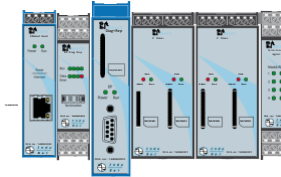

Oscilloscope data 14.03.2013

14.03.2013 13:01:42	🔍	📄
14.03.2013 13:01:44	🔍	📄
14.03.2013 13:01:46	🔍	📄
14.03.2013 13:01:48	🔍	📄
14.03.2013 13:01:51	🔍	📄

- Main module
- Module - DP-Rep
  - Event list
  - Snapshots
  - Settings
  - PB-Devices
  - State Calculation
  - Firmware
- Module 3 - DP
- Module 4 - PA
  - Event list
  - Snapshots
  - Settings
  - PB-Devices
  - Sate Calculation
  - Firmware



Quality rate

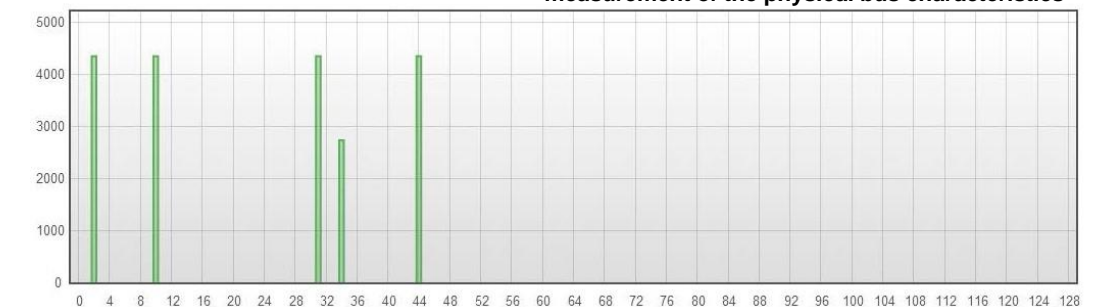

Display shows quality figures of the data transfer: measurement of the physical bus characteristics

Device	Date	Value	Glitch Flaw Counter	Edge Flaw Counter	Level Flaw Counter	Rising Edge	Falling Edge
2	06/27/2013 10:59:29 AM	2356	0	0	0	1	1
40	06/27/2013 10:59:30 AM	2480	1	0	0	1	1

## INBLOX® DP Diag Rep

### Function

The **DP Diag Rep** extension is provided with four terminals and can thus open four segments each. It is connected to the head and coupled directly via a backplane bus. No separate voltage supply is thus needed. Each head can be provided with up to five of these extension modules by which up to 25 segments (basic repeater) or 20 segments (E-head) can be created per network. The PROFIBUS can be converted from its original line topology to a star topology and spur lines designed without reservation. An initial simple diagnosis and monitoring is made by the LEDs provided. If connected to an E-head, a diagnosis can also be done via the web interface.

### Technical data

- Voltage supply: 24 VDC with a backplane bus
- Power supply: 0,3 A with a backplane bus
- Connection: 4 screw terminals – OUT (assignment: shield / B / A / shield)
- Baud rate: 9,6 kbps to 12 Mbps

### General data

- Installation: 35 mm DIN top-hat rail
- Dimensions (H x W x D): 114,5 x 22,5 x 99 mm
- Protective system: IP20
- Operating temperature: 5 °C to 55 °C
- Storage temperature: -20 °C to 70 °C
- PROFIBUS-Types: DP, DP-V1, FMS, MPI

### Terminal configuration

#### PROFIBUS DP

Terminal connection for DP

Channel 1	Channel 2
2 B	6 B
3 A	7 A
1+4 Shield	5+8 Shield

Channel 3	Channel 4
10 A	14 A
11 B	15 B
9+12 Shield	13+16 Shield

#### LED-index

LED	Color	Meaning
DP1	Green	Module 1
DP2	Green	Module 2
DP3	Green	Module 3
DP4	Green	Module 4
Bus (Bus-Quality)	Green	Everything is o.k.
Data (Bus-Aktivität)	Green	Data traffic exists
BUS-LED	Green	lights up green, if everything is o.k.
BUS-LED	Red	Failure identified e.g.
Data-LED	Green	data traffic exists
Data-LED	Red	Error telegrams, Repeat telegrams, Device failures, Diagnostic messages, Noise failure

### Ordering details

Extension DP Diag Rep

### Art. No.

124060009



DP Diag Rep

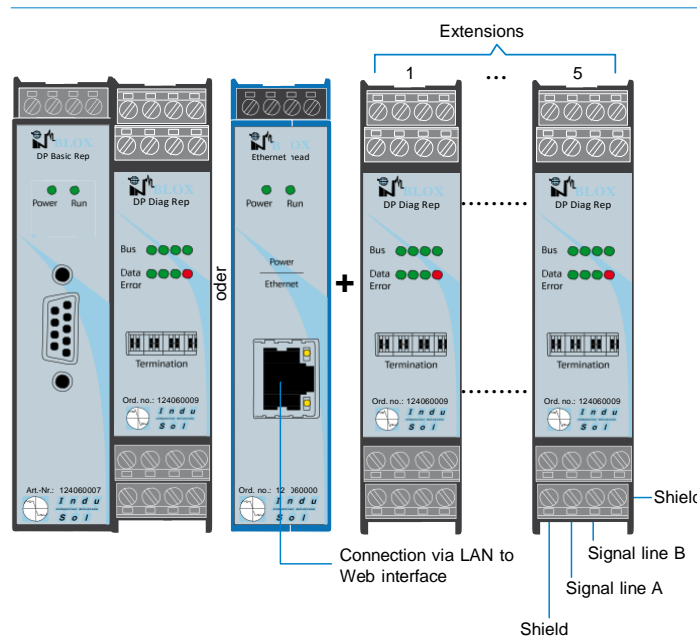
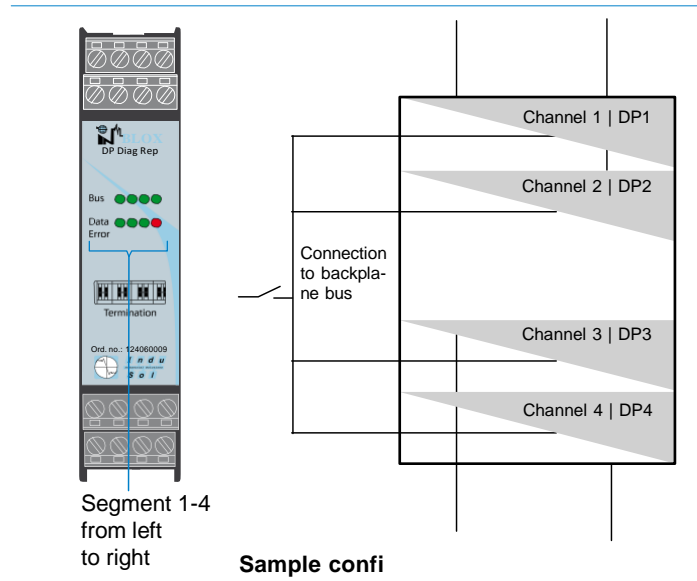

Sample confi

## INBLOX® alarm module

### Function

The **alarm module** comes with four terminals and is capable of monitoring one INBLOX® module per terminal. If available, it is always the last module to be connected and is coupled directly via a backplane bus. Therefore no separate voltage supply is needed. Every terminal/channel has got a switching output for alarms and a reset input. The alarm module can be installed in connection with the E-head only. In case of alarm the alarm LED lights up until it is cleared manually via the web interface or the reset input is actuated. The different alarm LEDs show which INBLOX® module is affected. The web interface of the E-head is used to select the relevant module to show the relevant device and detailed information.

### Technical Data

- Connection: 4 screw terminals
- Voltage supply: 24 V with a backplane bus
- Power supply: 0,3 A with a backplane bus

### General Data

- Installation: 35 mm DIN top-hat rail
- Dimensions (H x W x D): 114,5 x 22,5 x 99 mm
- Protective system: IP20
- Operating temperature: 5 °C to 55 °C
- Storage temperature: -20 °C to 70 °C

### Terminal configuration

#### Alarm module

Terminal connection

Alarm for module 1	Alarm for module 2
1 IN+	5 IN+
2 IN-	6 IN-
3+4 OUT	7+8 OUT

Alarm for module 3	Alarm for module 4
9 IN+	13 IN+
10 IN-	14 IN-
11+12 OUT	15+16 OUT

#### LED-index

LED	Color	Meaning
Alarm-LED	Green	Module 1
Reset input	Green	Module 2
Alarm-LED	Green	Module 3
Alarm-LED	Green	Module 4

Alarm-LED module 1-4: signal lights red, when alarm is lying ahead

Reset input: light up green, if connected

### Ordering details

Extension alarm module

### Art. No.

124060006



Alarm module

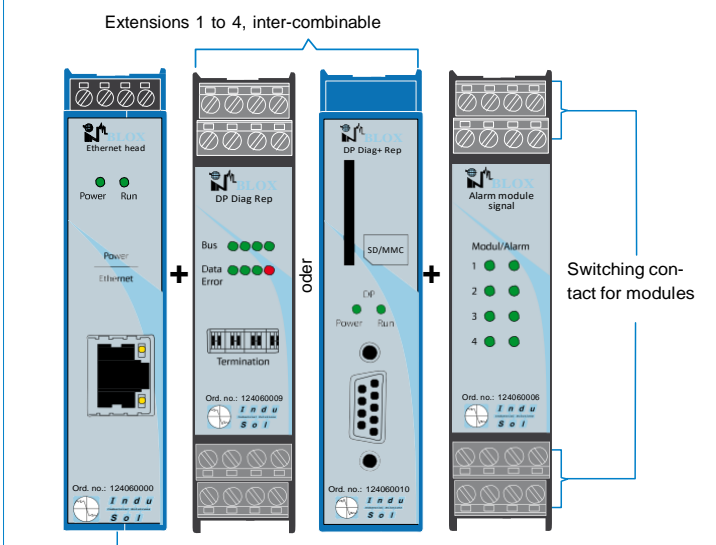
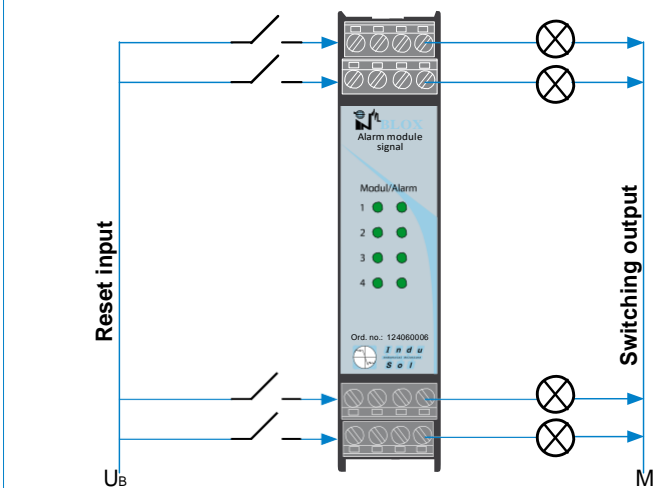

Sample confi



### Standard repeater IP20

#### Function

Repeaters make it possible to extend the PROFIBUS network to a maximum of 126 users the speed-dependent line length. The voltage signal is regenerated in both directions by the repeater whereas the signal content remains the same. From the physical point of view two segments are created that are metalically separated from each other. Each segment can have up to 32 users. The repeater regenerates the voltage signal in both directions and elevates it to the standard PROFIBUS level. The signal content remains unchanged, however. From the physical point of view two segments are created by the use of a repeater that are galvanically isolated.

#### Application instruction

Up to max. 4 repeaters (with Siemens up to 9 repeaters) can be connected in series. The repeater has no PROFIBUS address, but should be considered in the hardware configuration under „Network settings“. For the purpose of diagnostic measurements a measuring point should be provided at the beginning and end of the two segments. The 9-pin sub-D interface at the repeater can only be used for the incoming segment (DP1). If a segment ends or begins directly at the connections of the repeater, it is necessary to activate the bus terminating resistors for DP1 and DP2 by the slide switch.

#### Bus connection

The PROFIBUS is connected by a screw-type terminal either at the top side or the bottom of the repeater and split into two segments. The voltage is also supplied at the top of the repeater. The cables for power supply are beside the PROFIBUS cables and are easy to reach when mounted.

#### Electrical parameters

- Supply voltage (rated voltage): 24 VDC (20,4 V to 28,8 V)
- Current drain at rated voltage without users at the diagnosis interface: 200 mA
- Current drain at rated voltage with users at the diagnosis interface: 230 mA (5 V / 90 mA)
- Current drain at rated voltage with users at the diagnosis interface: 300 mA (24 V / 90 mA)
- Permissible transmission rate: 9.6 kbps to 12 Mbps

#### Ambient conditions

- Operating temperature: 0 °C to +60 °C
- Transport / storage temperature: -40 °C to +70 °C
- Relative humidity: max. 95 %, up to +25 °C
- Industrial protection: IP20

#### Mechanical and technical properties

- Dimensions (H x W x D): 128 x 45 x 58 mm
- Weight: approx. 350 g
- Installation: the repeater is snapped onto a „high“ top hat rail.

Ordering details	Art. No.
Standard repeater IP20	110030000



Standard repeater IP20

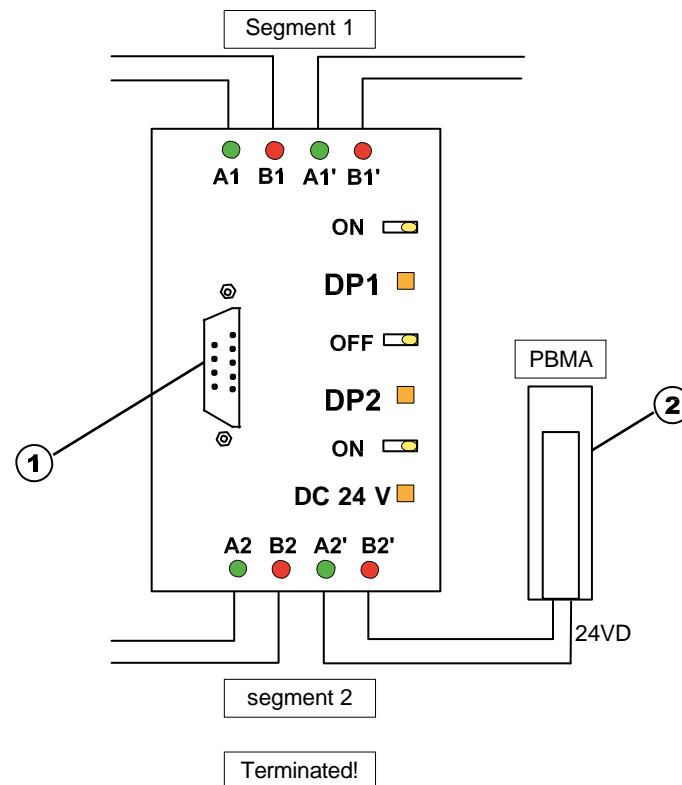

- ① measuring and programming interface - segment 1
- ② measuring and programming interface - segment 2 using PBMA (to be installed later)

Engineering drawing

### Diagnostic repeater IP20

#### Function

The repeaters make it possible to extend the PROFIBUS network to maximum 126 users including the repeaters. The voltage signal is regenerated in three directions by the diagnostic repeater. But the signal content remains the same. From the physical point of view three segments are created that are metalically separated from each other. Up to 32 users are permissible per segment. According to the PROFIBUS guideline, the termination is performed at the start as well as the end of each segment. The diagnostic repeater features a PROFIBUS address and thus a, has to be integrated into the hardware configuration of the master.

#### Application instruction

When using a diagnostic repeater, a maximum of three metalically separated segments are created. It should therefore be ensured that there is a measuring point at the start as well as the end of this just created segment when diagnostic measurements are necessary. The sub-D interface placed on the repeater can not be used for the physical diagnostic measurements. Application only for masters from Siemens! The maximum length of the segment should be 100 meters.

#### Bus connection

The PROFIBUS is connected through the Fast Connect IDC method of terminatin on the bottom side of the repeater and can be split into three segments. The voltage is also supplied from the bottom of the repeater.

#### Electrical parameters

- Supply voltage: 24 VDC (20,4 V to 28,8 V)
- Permissible transmission rate: 9.6 kbps to 12 Mbps

#### Ambient conditions

- Operating temperature: 0 °C to +60 °C
- Transport / storage temperature: -40 °C to +70 °C
- Relative humidity: approx. 95 % at a temperature of 25 °C
- Industrial protection: IP20

#### Mechanical and technical properties

- Dimensions (H x W x D): 125 x 80 x 66 mm
- Weight: approx. 300 g
- Installation: the repeater is snapped onto a „high“ top hat rail.
- Electrical isolation: The PROFIBUS segments 1, 2 and 3 are opto-galvanically separated from each other.

#### Diagnostics

The repeater diagnoses and reports the following data to the master:

- Line interruption
- Short circuit
- Line length
- Topology

Ordering details	Art. No.
Diagnostic repeater IP20	110030003



Diagnostic repeater IP20

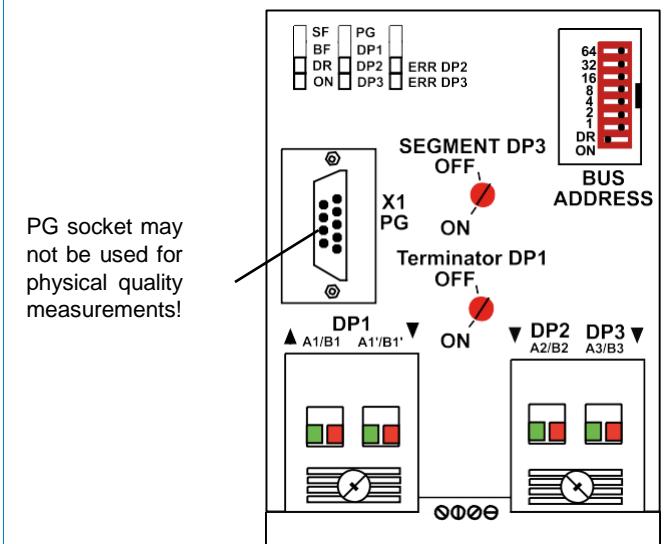

PG socket may not be used for physical quality measurements!

Engineering drawing

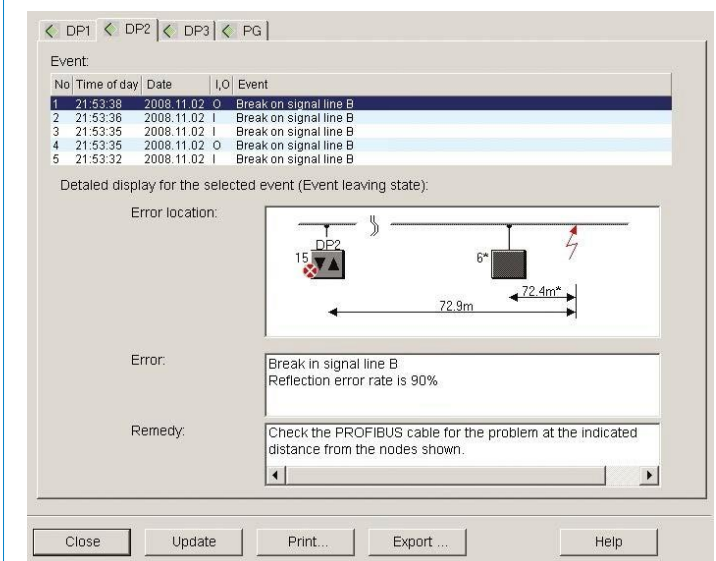

Diagnostic function

### Compact repeater

#### Function

The **Compact repeater** is the smallest repeater of the PROFIBUS world but despite its smallness it can keep up with the big ones. It regenerates the signals in edge steepness, level and duty factor. The repeater is capable of supplying 32 devices over the full line distance as permitted by directive up to a max. transfer rate of 12 Mbps. It is installed instead of the standard PROFIBUS connector plug it is installed by direct plugging on the D-subminiature connector of a PROFIBUS device configured in the network.

Should the required place of installation be freely selectable, the PBMB module specifically developed for this purpose must be used. The voltage supply (+24V) is converted internally through a DC/DC transformer to +5 V and directly fed to the repeater by a standard pin assignment 5 and 6.

#### Information on use

The implementation of active spur lines is seen as a main field of use. Functions and operating states of the repeater are signalled by the integrated LED displays.

#### Electrical parameters

- Voltage supply: + 5 VDC realized via PIN 5 and 6 directly from the slave or additional module PBMB
- Baud rate: 9,6 kbps to 12 Mbps (automatic recognition)
- Power input: approx. 100 mA
- Connection: insulation displacement connector technology (segment 1 and 2) via suB-D switch (segment 1)

#### Ambient conditions

- Operation temperature: 0 °C to +60 °C
- Storage temperature: -25 to +75 °C
- Protective system: IP20

#### Design

- Dimensions (H x W x D): 64 x 17 x 40 mm
- Weight: approx. 40 g
- Material casing: metallized plastic casing

#### LED status display

<b>Power</b>	blue	flashing	Repeater is detecting transfer rate
		Steady light	Transfer rate was detected
	green	flashing	Repeater is detecting transfer rate
		Steady light	Transfer rate was detected
<b>Error</b>	red	Failing data are recognized on segment 2	
<b>BUS</b>	yellow	Data traffic on segment 2	

Ordering details	Art. No.
Compact repeater	110030004



Compact repeater

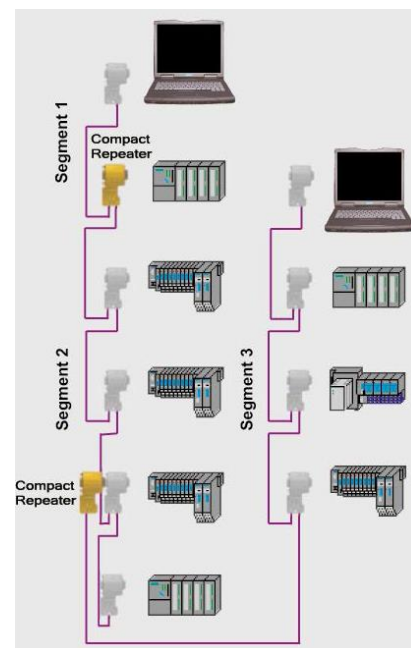

Example of use

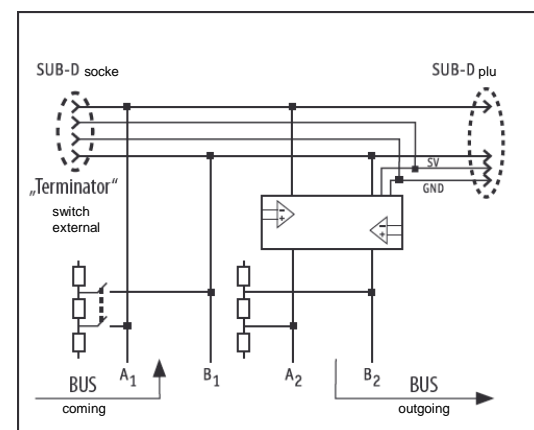

Interface diagram

### Repeater IP67 MR (rough conditions)

#### Function

With the **Repeater IP67** it is possible to build up two galvanically separated PROFIBUS-DP segments. By using repeaters, up to 126 PROFIBUS-DP users can operate via one master (maximum 32 users per segment). The transfer rate is automatically recognized. According to the PROFIBUS guideline the termination is done at the beginning and end of a segment. The use of IP67 repeaters creates two galvanically isolated segments.

#### Bus connection

According to the PROFIBUS guidelines, the PROFIBUS-DP is connected through inversely encoded M12x1 plug-and-socket connectors. The supply voltage is fed via a standard 7/8" plug-and-socket connector.

#### Electrical parameters

- Supply voltage: 24 VDC (18 to 30,2 V)
- Permissible transmission rate: 9.6 kbps to 12 Mbps

#### Ambient conditions

- Operating temperature: 0 °C to +55 °C
- Industrial protection: IEC 60529 / EN 60529 IP67 and NEMA 1, 3, 4, 12, 13

Not needed plug-and-socket connectors have to be screwed with the plastic caps provided for that purpose.

#### Design

- Casing: Dimensions (H x W x D): 36 x 151 x 30 mm
- Installation: 2-hole screw fixing
- Connections: main power supply through 7/8" plug PROFIBUS through M12 plug (B-encoded)
- Electrical isolation: The PROFIBUS segments 1 and 2 are galvanically isolated.

#### Status display

- Communication to fieldbus: LED green static - „i.O. „
- Internal communication US: LED static - „OK“
- LED flashing - no data exchange

Ordering details	Art. No.
Repeater IP67 MR (rough conditions)	110030002



Repeater IP67 MR (rough conditions)

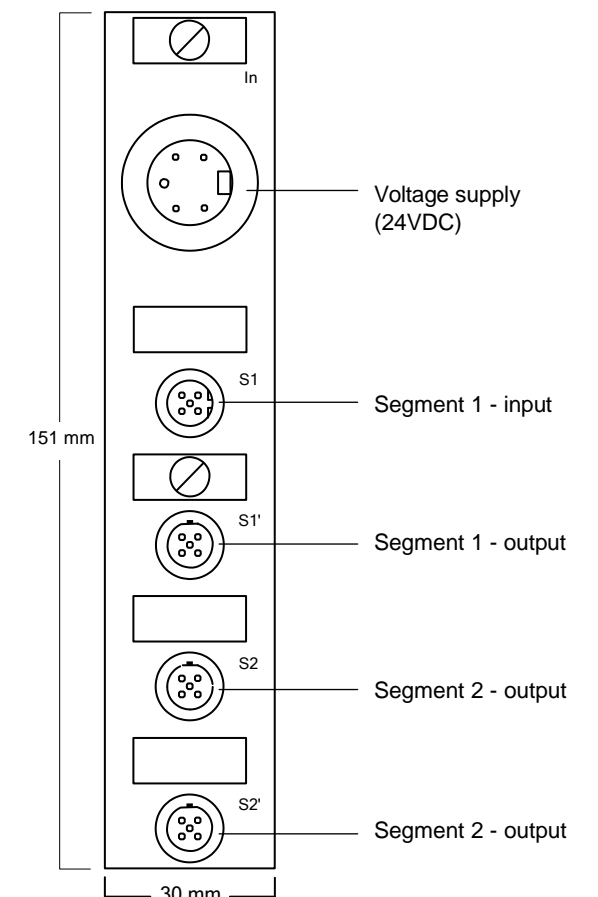

Engineering drawing

## Line standard

### Function

The **standard line** is intended for a firm installation in dry and wet rooms. The double shielding makes the line suitable for use in an electromagnetic environment. This line is used for field bus systems, such as PROFIBUS DP; PROFIBUS FMS, Siemens SIMATEC NET which are all in accordance with DIN 19245, section 3 and EN 50170 cable type A as well as for the high-performance network bus line that has a rated impedance of 150 ohm. The fieldbus line is rated for transmission speeds of up to 12 Mbps. This line type is designed for a routed line laying either in dry or damp locations. The dual-shielding makes this line particularly suitable for use in electromagnetically loaded areas.

### Application instruction

The standard field bus line is suitable for applications where the mechanical/chemical loads are low. It is also designed for system-related transmission rates between 1.5 Mbps and 12 Mbps. The transfer characteristics are system-confirming and thus ensure a high secure of data transmission. Together with the FastConnect stripping tool it can be used for rapid contacting. The line end can be prepared for a ready-to plug connection in one work step, particularly for the IDC (Insulation Displacement Connector) method of termination.

### Electrical properties

- Surge impedance: 150 ±15 Ohm
- Loop resistance: max. 115 Ohm / km
- Rated voltage: 30 V

### Design

- Line type: cable line A
- Conductor: single-wire copper conductor, blank, Ø 0,64 mm
- Insulating sheath: foam - skin (02YS)
- Innenmantel: zwickelfüllend extrudiert
- Shield: plastics-coated aluminium foil, metal side outside, braid of tin-plated copper wires
- Jacket: PE flameproof; outer diameter approx. 7,8 mm
- Colour: violet
- Line weight: 60 kg / km

### Mechanical and thermal properties

- Minimum bending radius: for one-off usage: 75 mm  
for repeated usage: 150 mm
- Temperature range: moved: -5 °C to +50 °C  
fixed: -40 °C to +80 °C
- Admissible pull: 100 N
- Halogen-free: no
- Oil resistant: depending
- UV resistant: no

Ordering details	Art. No.
------------------	----------

Line standard	110070000
---------------	-----------

### Accessories

PROFIBUS Fast Connect Stripping Tool	110020032
--------------------------------------	-----------



Line standard

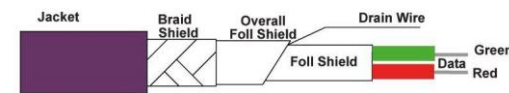

Engineering drawing

## Line flexible

### Function

The PROFIBUS **line flexible** is used for highly flexible energy chains and constantly moving machine parts. The dual shielding makes this line type perfectly for electromagnetically loaded areas.

### Application instruction

Highly flexible bus lines used for the PROFIBUS standard according to DIN 19249, section 3 and EN 50170 as well as high-performance data networks with a rated impedance of 150 W. This field bus line is rated for transmission rates of up to 12 Mbps.

### Electrical properties

- Surge impedance: 150 Ohm ±15 Ohm
- Loop resistance: max. 145 Ohm / km
- Rated voltage: 30 V

### Design

- Line type: cable line A
- Conductor: copper wire blank, (19 ´ 0,13), 0,25 mm² (24 AWG)
- Insulating sheath: PE or foam-skin (02YS)
- Shield: plastic-laminated aluminium foil metal side outside, braid made of tin-plated copper wires
- Jacket: PE flameproof; outer diameter approx. 8,0 mm
- Colour: violet
- Line weight: 64 kg / km

### Mechanical and thermal properties

- Minimum bending radius: 65 mm
- Temperature range: -40 °C to +80 °C
- Admissible pull: 100 N
- Halogen-free: yes
- Oil resistant: resistant to mineral oils and fats
- UV resistant: yes

Ordering details	Art. No.
------------------	----------

Line flexible	110070001
---------------	-----------

### Accessories

PROFIBUS Fast Connect Stripping Tool	110020032
--------------------------------------	-----------

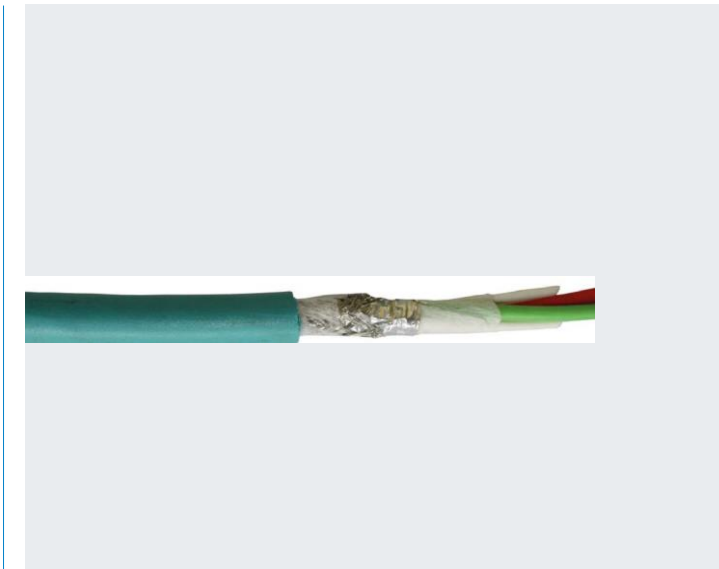

Line flexible

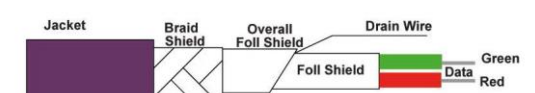

Engineering drawing

Line extreme

**Function**

The PROFIBUS **line extreme** has a very high abrasive resistance accompanied by an almost unlimited oil resistance. The data transmission reliability is guaranteed by the special overall braided screen.

**Application instruction**

The PROFIBUS Line extreme is meets highest demands when it comes to laying. The extremely high bending resistance of both the conductor material and braided screen provide for optimal and reliable use in energy chains. Its resistance to oils, fats and coolants makes this line type also ideal for permanent installation in machine tool workshops.

**Electrical properties**

- Surge impedance: 150 Ohm ±15 Ohm
- Loop resistance: approx. 78 Ohm / km
- Rated voltage: 30 V

**Design**

- Line type: cable type A, PCV and halogen-free
- Conductor: extra fine stranded wire conductor in extremely bending-resistant type of blank copper wires
- Insulating sheath: PE foam skin, radially distributed
- Interior lining: TPE mixture tailored to e-chains requirements, halogen-free,
- Shield: extremely bending-resistant tin-plated copper shield coverage about 70%, linear > 85% optical
- Jacket: TPE extremely abrasion-resistant, highly bending-resistant, oil and coolant-resisting mixture  
Außendurchmesser approx. 8,5 mm
- Colour: violet (comparable with RAL 4001)
- Line weight: 80 kg / km

**Mechanical and thermal properties**

- Minimum bending radius (for use in e-chain):  
moved: 10 x line diameter  
fixed: 5 x line diameter
- Temperature range:  
moved: -35 °C to +70 °C  
fixed: -40 °C to +70 °C
- Halogen-free: yes
- Oil resistant: resistant to oils and bio-oils
- UV resistant: high
- Regulations: Made according to the EU Directive (RoHS) 2002/95/EC.

Ordering details	Art. No.
------------------	----------

Line extreme	110070002
--------------	-----------

Accessories	
-------------	--

PROFIBUS Fast Connect Stripping Tool	110020032
--------------------------------------	-----------

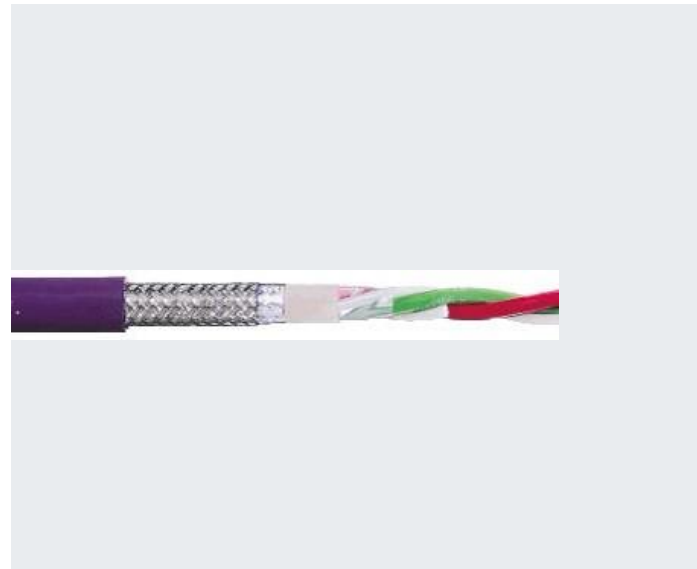

Line extreme

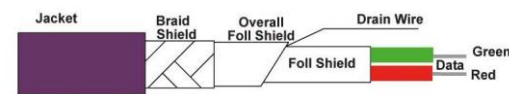

Engineering drawing

M12 Bus termination (B-coded) IP67

**Function**

The **Bus termination IP67** is used to properly terminate a PROFIBUS DP segment. Because of its external voltage supply, as many users as required can be either connected or disconnected without creating any disturbances on the bus.

**Electrical parameters**

- Supply voltage: max. 5 VDC

**Ambient conditions**

- Operating temperature: -40 °C to +85 °C
- Industrial protection: IP67 and NEMA 1, 3, 4, 6 P

**Design**

- Bus connection: plug, M12x1 (B-encoded)
- Casing: plastic  
M12 plug, oil-resisting
- Contact carrier: M12 plug PA6 (plastic mat.)
- Contact material: gold-plated brass



M12 Bus termination (B-coded) IP67

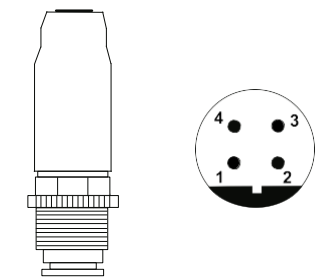

Engineering drawing

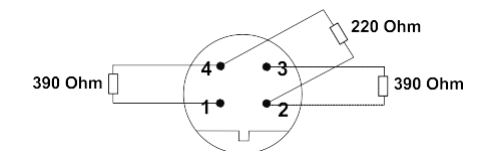

- Pin 1: 5 V
- Pin 2: A line (green)
- Pin 3: 0 V
- Pin 4: B line (red)

Pin assignment

Ordering details	Art. No.
------------------	----------

M12 Bus termination (B- coded) IP67	110100000
-------------------------------------	-----------

### Control cabinet bushing M12 (B-coded)

#### Function

The cable entry into switchgear cubicles or terminal box is rendered through a **bushing**. The bus lines are connected via B-encoded M12 plug-and-socket connectors.

#### Application instruction

The M12x1 bushing is designed for PROFIBUS lines to be laid in switchgear cubicals, terminal boxes etc. The connection is realised by B-encoded plug-and-socket connectors. Holes of 12.7 mm diameter are needed for the M12x1 bushings.

#### Ambient conditions

- Operating temperature: -40 °C to +80 °C
- Industrial Protection: IP67 and NEMA 1, 3, 4, 6

#### Design

- Casing for plug-and-socket connector: nickel-plated brass, creepage and clearance in air to VDE 0110, size C (250 V AC /300 VDC)
- Contact carrier: PA6 (plastic)
- Contact material: gold-plated brass



Control cabinet bushing M12 (B-coded)

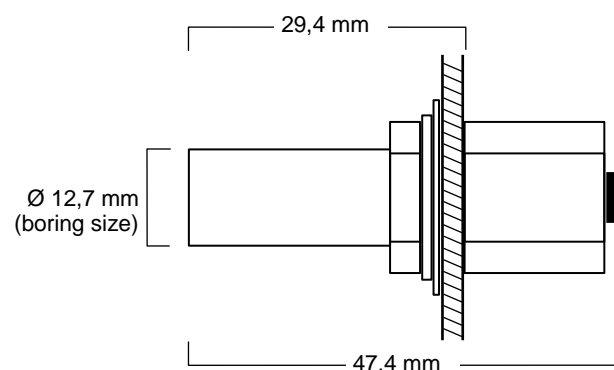

Engineering drawing

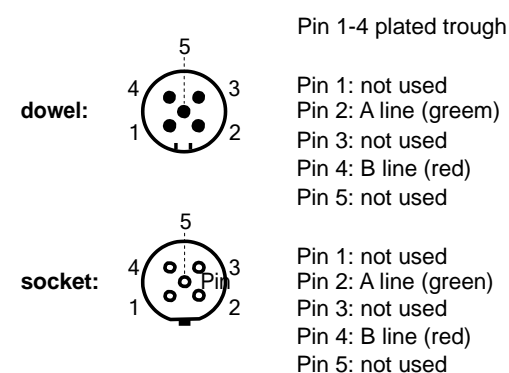

Pin assignment

Ordering details	Art. No.
M12 Control cabinet bushing M12 (B-codiert)	110060000

### T piece M12

#### Function

The **T piece M12 compact** is used to connect PROFIBUS devices.

#### Ambient conditions

- Operating temperature: -40 °C to +80 °C (250 °C short-term)
- Industrial protection: IP67 and NEMA 1, 3, 4, 6P

#### Design

- Contacts: gold-plated brass
- Cap nut: nickel-plated brass or stainless steel
- Server binder: housing and contact carrier of oil-resistant polyerethane



T piece M12

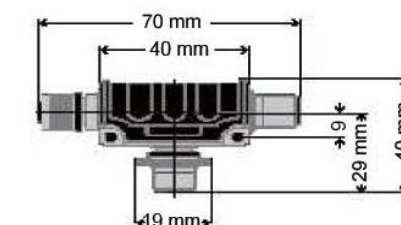

Engineering drawing

M12x1 dowel M12x1 socket



Pin 1: not used  
Pin 2: A line (green)  
Pin 3: not used  
Pin 4: B line (red)  
Pin 5: not used

Pin assignment

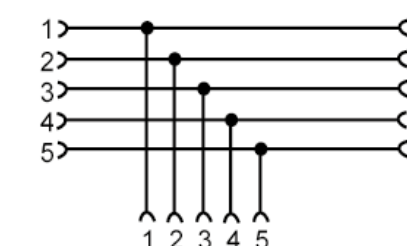

Wiring diagram

Ordering details	Art. No.
T piece M12	110100001

### T pieces M12 compact

#### Function

The **T piece M12 compact** is used to connect PROFIBUS devices. Encoding turned by 90°

#### Technical data

- Encoding: B - invers
- Rated current: (TU = 40 °C), 4 A
- Volume resistance:  $\leq 5 \text{ m}\Omega$
- Rated transient voltage: 1 kV
- Insulation resistance:  $\geq 1 \text{ G}\Omega$
- Pin diameter: 1 mm
- Category of overvoltage: II

#### Ambient conditions

- Working temperature: -25 °C to +80 °C
- Protective system: IP68
- Pollution degree: 3

#### Design

- Pole number: 4
- Operating voltage [V]: 4-pol. 30 VAC
- Contacts: CuSn
- Contact surface: Ni/Au
- Contact carrier: PUR
- Body: PUR
- Knurled screw: brass nickel-plated
- Sealing: Viton
- Mechanical life: min. 100 plug cycles



T pieces M12 Compact

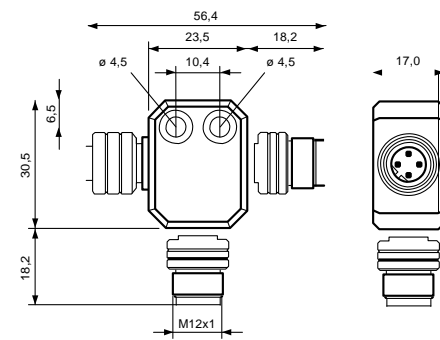

Engineering drawing

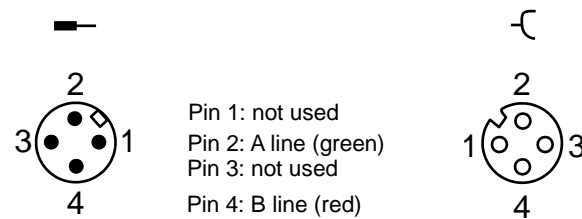

Pin assignment

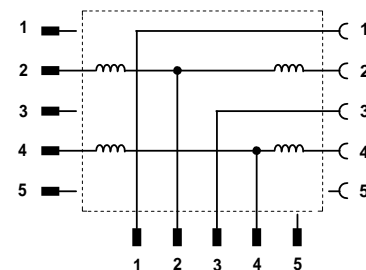

Wiring diagram

Ordering details	Art. No.
T pieces compact M12	110100002

### T pieces M12 (PROFIBUS PA)

#### Function

**T piece M12 (PROFIBUS PA)** serves as connector of PROFIBUS PA devices.

#### Technical data

- Rated current: max. 250 V
- current carrying capacity: 4 A
- Insulation resistance:  $\geq 10^8 \Omega$
- Volume resistance:  $\leq 5 \text{ m}\Omega$

#### Ambient conditions

- Umgebungstemperatur Verteiler: -30 °C to +90 °C
- Protective system (Dummy): IP67, nur im verschraubten Zustand
- Protective system (Steckverbinder): IP67, nur im gesteckten Zustand
- Verschmutzungsgrad: 3/2

#### Design

- Pole number: 4
- plug-in connector: coupler, 2x, M12x1, straight plastic, PA 6, black
- Griffkörper: plastic, TPU, black
- Contact carrier: metal, CuZn, gold plate
- Contacts: metal, CuZn, nickel plate
- union nut and screw: plastic, FPM (Viton)
- Sealing: min. 100 plug cycles
- Mechanical life:

#### CE-Kennzeichnung

Stecker sind passive Bauelemente und unterliegen nicht der CE-Kennzeichnung gemäß der EU-Richtlinien.



T pieces M12 (PROFIBUS PA)

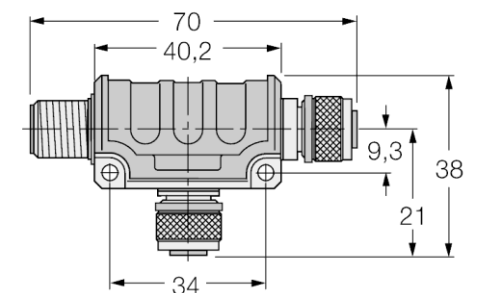

Engineering drawing

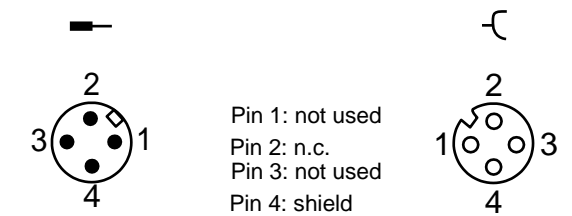

Pin assignment

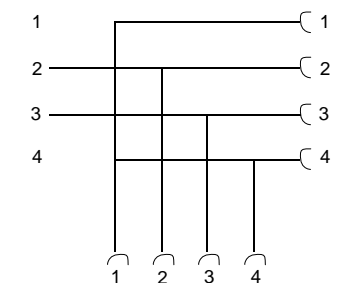

Wiring diagram

Ordering details	Art. No.
T pieces M12 (PROFIBUS PA)	110100003

**Power line M12 (socket, A-coded)**

**Function**

This **power line** is used to connect the measuring adapter PBMX IP67. It also meets all requirements necessary for connection of a standard M12 sensor.

**Electrical parameters**

- Conductor cross-section: 3 x 0,34 mm<sup>2</sup>
- Rated current: 4 A
- Voltage: max. 30 V

**Ambient conditions**

- Operating temperature:
  - fixed: -30 °C to +70 °C
  - moved: -5 °C to +70 °C
- Drag-chain capable: yes
- Halogen-free: no
- Industrial protection: IP67 (plugged state)

**Design**

- Cable material: PUR / PVC
- Outer jacket: grey

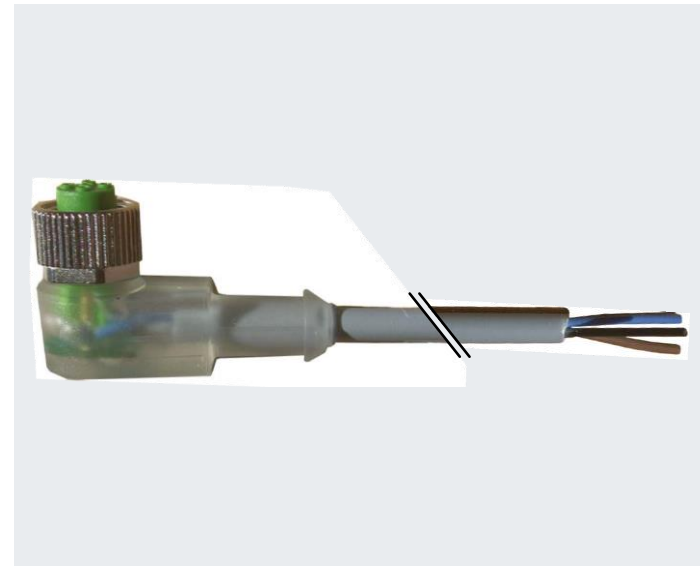

Power line M12 (socket)

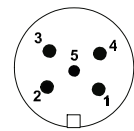
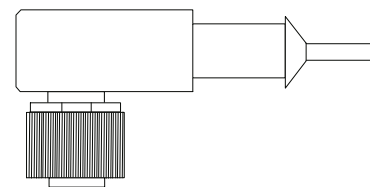

Pin 1: brown (+)  
 Pin 2: not used  
 Pin 3: blue (-)  
 Pin 4: black  
 Pin 5: not used

Engineering drawing

Ordering details	Art. No.
Power line M12 (socket) 3 meter	110070008
Power line M12 (socket) 5 meter	110070009
Power line M12 (socket) 10 meter	110070010

**3. Infrastructure components**

sheet

<b>Ethernet / PROFINET</b>	
<b>Measuring point</b>	<b>110</b>
Active measuring point ETMA	110
Control cabinet bushing SSD	111
<b>Switches</b>	<b>112</b>
Modulare and Compacte Industriell Switches (manageable)	112
<b>Connection elements</b>	<b>113</b>
RJ45 patchfield fast connect	113
<b>Cable</b>	<b>114</b>
Light patch cable Cat 5e ready made-up	114
Light patch cable Cat 5e ready made-up	116
Heavy patch cable Cat 5e ready made-up	117
PROFINET Cable Cat 5, solid	118
PROFINET Cable Cat 5, drag-chain capable	119
PROFINET Cable assemblies	120
<b>Plug</b>	<b>122</b>
RJ45 Plug 180 / 90	122
Connectors RJ45 / M12 to assemble	123
Round plug connector IE Fast Connect Plug PRO M12 (D-coded)	124

## Active measuring point ETMA

### Function

The **ETMA measuring point** serves for feedback-free telegram recording in Ethernet / PROFINET networks under production conditions. A permanent installation of the measuring point in the network connection between the automation equipment (SPC) and the first switch is recommended because typically the greater part of the communication converges in this connection.

Two RJ45 sockets are available at the unit. The ETMA should be connected to the analysis tool (PN-INspektor® - PIT) with two network cables (patch cable). By using the PN-INspektor® it is possible to read out and record in parallel the full duplex data traffic without telegram loss.

To analyse and evaluate the measuring results, the telegrams from both communication directions can be superimposed in terms of time. Error telegrams are not rejected by the ETMA but forwarded.

### Task: Telegram recording while the system is running

#### Normal recording by port mirroring

- Advantages:
- no additional hardware required (no ETMA)
- Disadvantages:
- time-consuming creation of mirror port at switch
  - high load of switch by mirror port
  - package losses at high data rates
  - bidirectional mirror port urgently required
  - defective telegrams are not mirrored

#### Recording through ETMA

- Advantages:
- no costly provision of measuring point
  - unconditionally bidirectional up to 100 Mbps
- Disadvantages:
- additional hardware
  - expert analyzer required

### Technical data

- Installation: 35 mm DIN top-hat rail
- Dimensions (H x W x D): 110 x 30 x 85 mm
- Power supply: external 24 VDC
- Connector: RJ45
- Delay time: less than 1 Bps at 100 Mbps
- Cable: Cat 5 / Cat 5E, max. 100 m
- Operating temperature: -15 °C to 75 °C
- Storage temperature: 0 °C to 50 °C
- Air humidity: 10 to 90 %, non-condensing
- Approvals: CE, FCC class B

### Notice for connecting

When connecting the PROFINet-INspektors® to an ETMA (TAP) please mind that one of the two lines between ETMA und INspektor® has to be a cross over cable.



Active measuring point ETMA

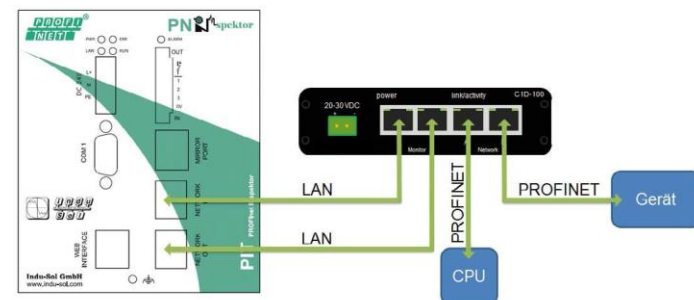

Example of connection for PROFINet-INspektor®

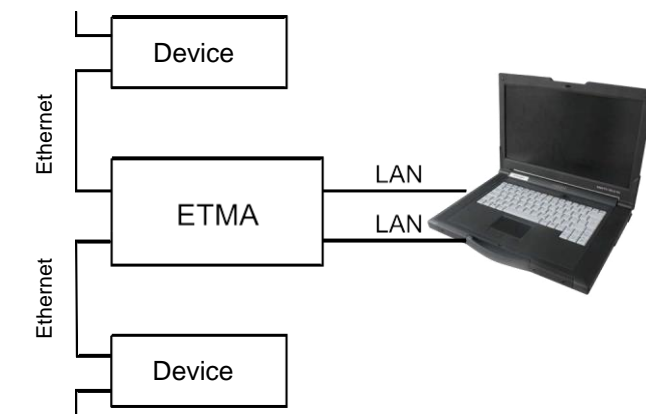

Analysis with laptop

Ordering details	Art. No.
ETMA (for top-hat rail)	112040001

## Control cabinet bushing SSD

### Function

With the SSD bushing for front mounting in control cabinets and terminal boxes you provide an easy and optimal access to your control cabinet by RJ 45 or USB.

Via the Ethernet and USB interfaces SPC and measuring point (ETMA) can be easily accessed from outside

### Connections

The SSD control cabinet bushing is available in two versions with connection for:

- Version 1 2 x RJ45
- Version 2 USB ad RJ45

### Electrical parameters

- Max. rated voltage / rated current: RJ45 - 48 VAC/DC / 1 A  
USB - 30 VAC/DC / 1 A
- Interlocking type: RJ45 - locking hook  
USB - snap-in
- Specification: RJ45 CAT5e;  
USB 2.0 / Type 2

### Electrical parameters - mains socket-outlet

- |                         |          |          |          |
|-------------------------|----------|----------|----------|
| • Norm:                 | D VDE    | USA NEMA | F UTE    |
| • Rated voltage (max.): | 250 V AC | 125 V AC | 250 V AC |
| • Frequency:            | 50 Hz    | 60 Hz    | 50 Hz    |
| • Rated current (max.): | 16 A     | 15 A     | 16 A     |

### Others on request

### Ambient conditions

- Industrial protection: IP64

### Design

- Dimensions (H x W x D): SSD-E: 113 x 66 x 35 mm (single)  
SSD-D: 113 x 130 x 35 mm (double)
- Frame: metal
- Lid: design: metal, black varnish

Ordering details	Art. No.
SSD-E RJ45 (single, 2 x RJ45)	110060005
SSD-D RJ45 (double with socket-outlet German, 2 x RJ45)	110060003
SSD-B RJ45 (double w. customized. mains socket-outlet, 2 x RJ45)	110060002
SSD-E USB (single, 1 x USB + 1 x RJ45)	110060007
SSD-D USB (double w. socket outlet German, 1 x USB + 1 x RJ45)	110060004
SSD-B USB (double w. customized mains socket-outlet, 1 x USB + 1 x RJ45)	110060001



Control cabinet bushing SSD

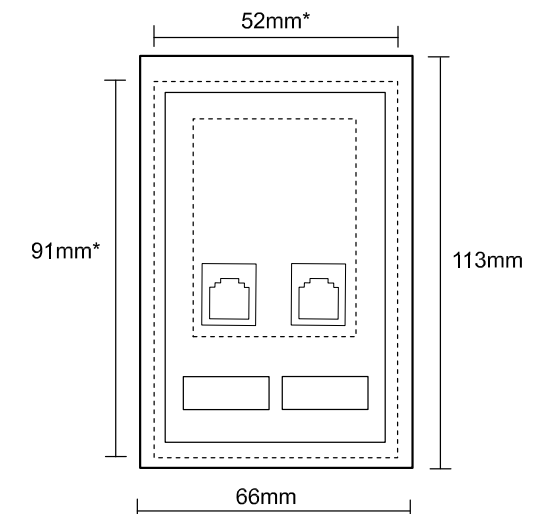

\*) size matches section

Engineering drawing



Modular and Compact Industrial Switches (manageable)

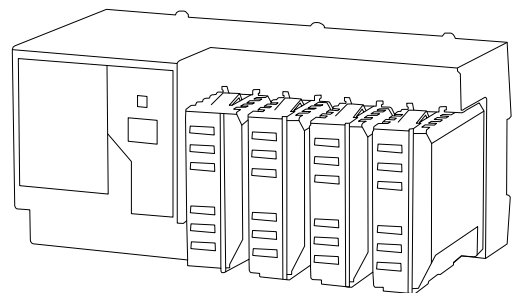

Schematic diagram of modular switch (manageable)

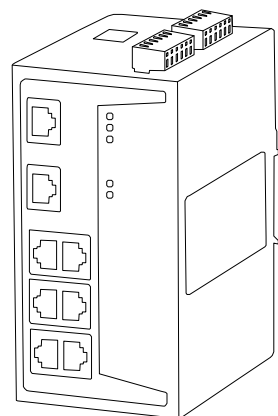

Schematic diagram of compact switch (manageable)

The industrial switches IP20 are installed in casings and have a variable number of Cu / LWL ports. The devices meet the elevated requirements of industrial uses e.g. (EMV / temperature / 24 VDC). All devices are fully manageable and can thus be used for ISI (commissinging / Service / Maintenance).

Switching Features

- Learning addresses
- Prioritization
- Broadcast limiter
- Modules upgradeable

Switching Features

- Learning addresses
- Prioritization
- Broadcast limiter
- Store and Forward

Selection parameters for manageable switches

	Type	Features	Connection(Cu, OWG)	Protection	Size	Data rate
	Compact Modular	SNMP Port Mirroring PROFINET-capable M12	RJ45 ST SC	IP20 IP65/67	4-8 Ports 8-16 Ports 16-24 Ports	10 Mbps 100 Mbps 1000 Mbps
1.						desired parameters (indicate quantity for type and connection)
2.						desired parameters (indicate quantity for type and connection)
3.						desired parameters (indicate quantity for type and connection)

Please tick the desired parameters and send the form by fax or email. Based on this information we will submit to you a non-binding offer. You can also print the form from our website. Gladly you can also print the form from our website:

Firm _____ Address <input type="checkbox"/> Mrs. <input type="checkbox"/> Mr. _____ First name _____ Surname _____	Street _____ Postal code, city _____ Phone _____ Fax _____
---	---

RJ45 patchfield Fast Connect

Function

The **RJ45 patchfield** serves for the transfer of the robust Industrial Ethernet / PROFINET lines used in industrial environment to ready made-up Ethernet lines (10 / 100 Mbps) by means of RJ45 sockets. By using several patch fields RJ45 in a row it is possible to built up a patch field of any number of connections. RJ45 patchfield with RJ45 LAN socket and ID contacts to connect the RJ45 with the Ethernet line in an industrial environment. All connectors used for PROFINET are shielded and designed for a row industrial environment.

Technical data

- Transmission characteristics: CAT 5
- Pin arrangement as per PROFINET geometry
- Geometry: RJ45
- Industrial protection: IP20
- Connection of industrial Ethernet FC lines: 4 ID termination for all IE cables 2 x 2 AWG 22 to 24 flexible AWG 22 to 23 solid
- Core diameters: max. 1,6 mm Ø
- Core insulation: 20 °C to +75 °C
- Operating temperature: 6,5 mm to 6,9 mm
- Cable jacket diameter: min. 750
- Contact durability: cast metal
- Casing: 108 x 31 x 37 mm
- Dimensions (H x W x D): standard sectional rail or wall-mounted
- Installation:

Pin assignment

Signal	denotation	Wire colour	configuration RJ45
TD+	Transmission Data +	yellow	1
TD-	Transmission Data -	orange	2
RD+	Receive Data +	white	3
RD-	Receive Data -	blue	6



RJ45 patchfield Fast Connect

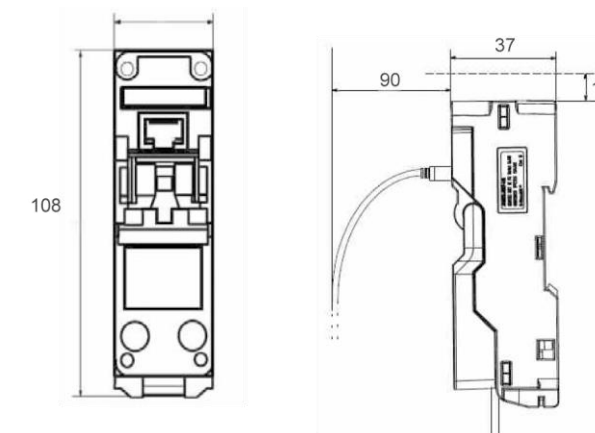

Engineering drawing

Ordering details	Art. No.
RJ45 patchfield Fast Connect	112030007

Light patch cable Cat 5e ready made-up

Function

Patch cables, in contrast to installation cables are due to their line structure considerably more flexible. They are used to connect between patch field and network node (switch/hub) [straight through], or between patch field and terminal [cross over]. Because of the various line length and plug-in connectors Indu-Sol offers customer and application specific products.

Cable construction

- PVC jacket
- 4-paired strand
- Twisted paired

Wire diameter

- 32 AWG (Cat 5e) (AWG = American Wire Gauge)

Wiring

- TIA / EIA 568-B / straight through

Connections

- Both ends RJ45
- Molded ends

Shielding

- FTP (Cat 5e):
  - no shielding of single wires to each other
  - overall layer foil / braid

Properties

- Wave impedance 100 ± 15 Ohm
- NEXT \
- Attenuation / - acc. ISO / IEC 11801
- ELFEXT /
- Return Losses

Assortment variety

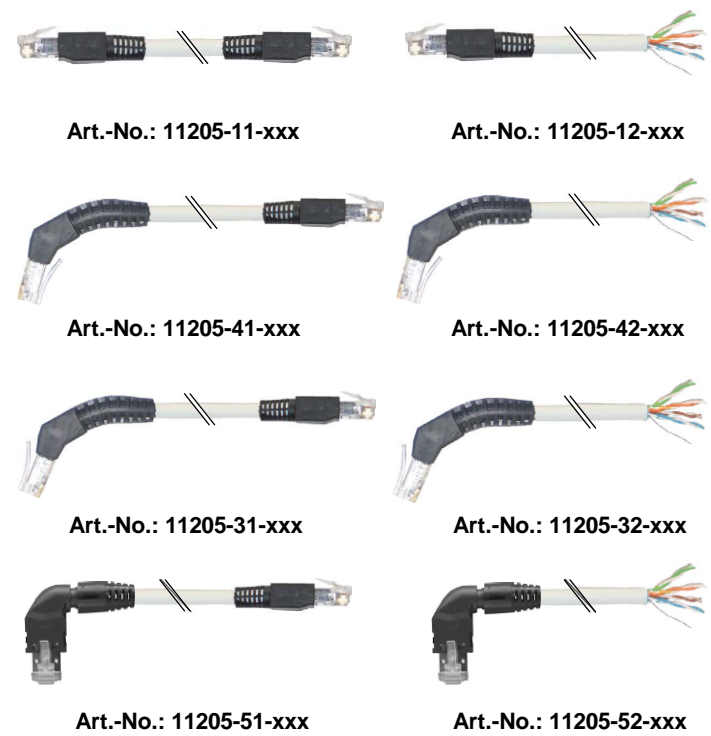

\_xxx (The line length is to be added to the article No. in purchase orders)

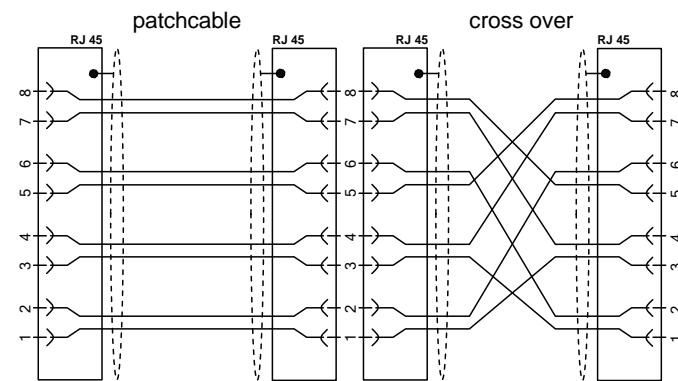

Engineering drawing

Light patch cable Cat 5e ready made-up

Ordering instruction

Cable end 1

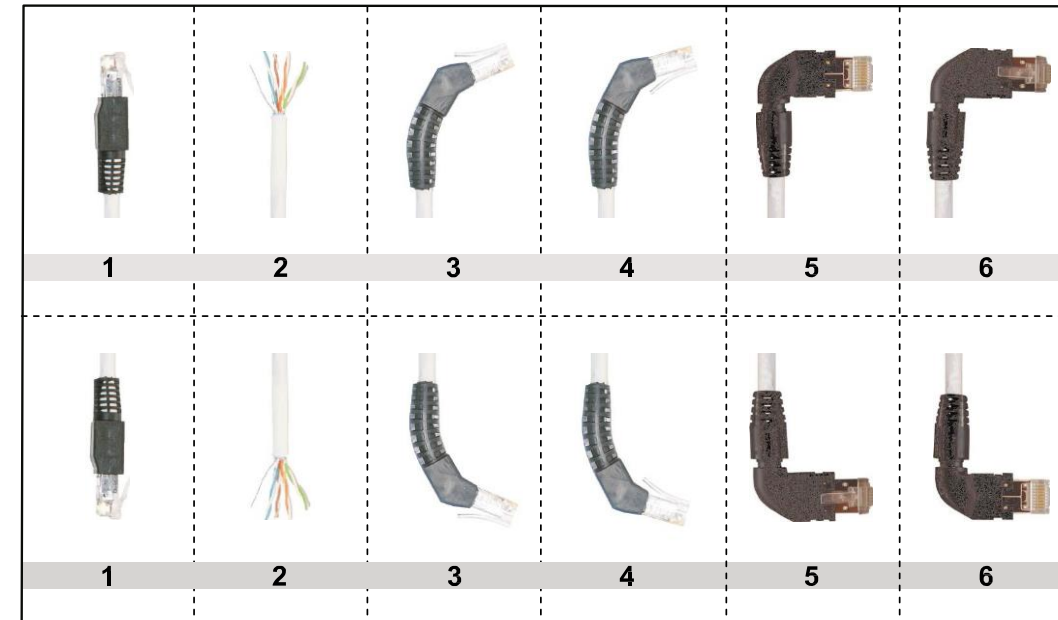

Cable end 2



**Cable length**

Patch cable  
Article-No.: 11205 - x x - xxx

Cross over  
Article-No.: 11206 - x x - xxx

Note

All versions are combinable on request and will be made according to the required cable length!

Ordering details	Art. No.
Light patch cable Cat 5e	11205-xx-x
Light patch cable Cat 5e cross over	11206-xx-x

The first two digits (xx) following the standard item number define the cable ends. The last digits (xxx) define the length of the cable. Any length can be selected (indicate in meters).

### Light patch cable Cat 5e - to assemble

#### RJ45 connector with crease protection

- Crease protection / rest lever protection: yes
- Jacket diameter, min.-max.: 5,5 -to7,1 mm
- Connector acc. to IEC 60603-7-5 (Norm): yes, to 250 Mhz
- Life cycle / contact durability : 750
- Diameter, solid: AWG 27/1 AWG 24/1
- Diameter, flexible: AWG 27/7 AWG24/7
- Cable withdrawing force: 89 N
- Electric strength, contact to contact: 1000 VDC
- Electric strength, contact to shield: 1500 VDC

#### Patch cable Cat 5e

- Two-core laid-up as pair
- 4 pairs stranded
- 4 x 2 x AWG 26 / 19
- Copper strand: 19 x 0,1 Ø 0,5 mm
- PP insulation: Ø 1,0 mm
- Braided shield by tinned copper wires
- Loop impedance: 260 W / km
- Surge impedance: 85 to 15 Ohm / km
- Drag-chain capable
- Permissible temperature range: -40 °C to +80 °C

#### Crimping tool

- Press moulding tool for 8-pole, shielded RJ45 connector
- Crosscut AWG 27 to 24

#### Scope of delivery

- 10 x RJ45 connector
- 10 m cable
- Crimping tool
- Quickstart guidance

Ordering details	Art. No.
RJ45 connector	112030006
Patch cable Cat 5	112070001
Crimp tool	112020006
Ethernet Fast Connect stripping tool	112020005



RJ45 Connector



Ethernet Fast Connect stripping tool



Crimp tool

### Heavy patch cable Cat 5e ready made-up

#### Function

**Patch cables**, in contrast to installation cables are due to their line structure considerably more flexible. They are used to connect between patch field and network node (switch/hub) [straight through], or between patch field and terminal [cross over].

#### Cable construction

- Two cores laid up as pair
- Four pairs stranded
- Filler
- Semi-conducting overlapped plastic film
- PE (PUR) jacket

#### Wires

- 4'2' AWG 26 / 19
- Copper strand: 19 ' 0,1 Ø 0,5 mm
- PP insulation : Ø 1,0 mm
- Pairs of wires: brown / brown and white  
blue / blue and white  
green / green and white  
orange / orange and white

#### Shielding

- STP (Cat 5e):  
- no shielding of single wires to each other  
- overall layer foil / braid

#### Connections

- RJ45 connector sprayed at both ends and additional cable relief

#### Electrical properties

- Loop impedance: 260 W / km
- Resistance difference: 3 %
- Signal delay time: 5,55 ns / m
- Insulation resistance: 150 MW ' km
- Surge impedance: 85 - 115 Ohm
  - Capacity: 50 nF / km
  - Attenuation: 23 dB

#### Properties

- Flameproof according to IEC 60332-1
- Oil-resisting according to IEC 60811-2-1
- Halogen-free
  - Admissible pull: 100 N
  - Permissible temperature range: -40 °C to +80 °C
- Fast Connect strippable
- Drag-chain capable and following properties:
  - 10 million bending cycles
  - min. bending radius: 7,5 ' max. Ø
  - max. speed: 180 m / min
  - max. acceleration: 5 m / s<sup>2</sup>

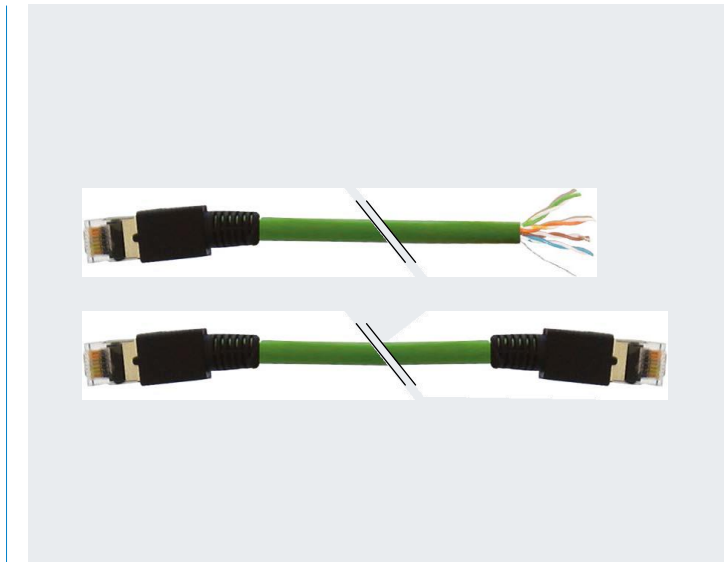

Heavy patch cable Cat 5e ready made-up

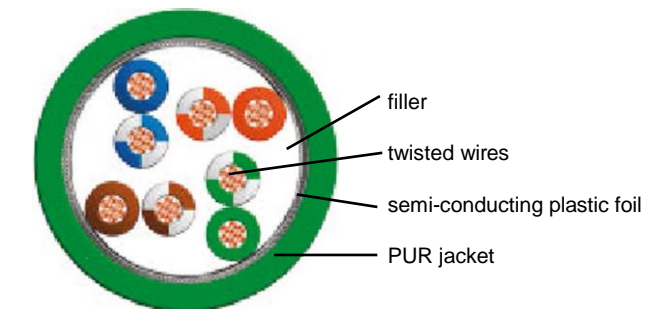

Engineering drawing

Ordering details	Art. No.
Patch cable Cat 5e* - connector at both ends	112070003
Patch cable Cat 5e* -connector at one end	112070002
Patch cable Cat 5e* - without connector	112070001
<b>Accessories</b>	
RJ45 connector protection cap	130020002
RJ45 connector IP20 field-wirable	112030003
M12 connector IP20 field-wirable	112030002
Ethernet Fast Connect stripping tool	112020005

\*) length on request

### PROFINET cable Cat 5, solid

#### Function

For a PROFINET network in an industrial environment only shielded cabling and connecting elements are permissible. Industry-suitable cables can be exposed to extremely mechanical load requiring a special structure. Plug-and-socket connectors and cables from a well-coordinated system. Only those elements that have proven their compatibility are called PROFINET units.

#### Wires

- Copper strand: 19' 0,15 / Ø 0,64 mm
- PE insulation: Ø 1,5 mm
- wire colors: yellow, orange, white, blue

#### Shielding

- Shield braid made of tinned copper wires
- Aluminum foil overlapping

#### Electrical properties

- Damping factor per length
  - at 10 MHz: 5,2 dB / 100 m
  - at 100 MHz: 19,5 dB / 100 m
- Loop resistance per length: 115 Ohm
- Insulation resistance coefficient: 500 MOhm \* km
- Surge impedance
  - at 1 Mhz - 100 MHz: 100 Ohm
- Coupling resistance
  - at 10 MHz: 10 mOhm / m
- Near-end cross-talk attenuation per length
  - at 1 MHz -100 MHz: 50 dB / 100 m

#### Mechanical data

- Outside diameter of
  - inner conductor: 0,64 mm
  - AWG cross section: AWG22
  - core insulation: 1,5 mm
  - inner sheath of cable: 3,9 mm
  - cable sheath: 6,5 mm
- Flameproof: UL 1685 (CSA FT 4)
- Halogen-free: No
- Silicon-free: Yes
- Chemical resistance to mineral oil: conditionally resistant
- Radiological resistance to UV radiation: resistant
- Admissible pull: 150 N
- Permissible temperature range during
  - Operation/transport/Storage: -40 °C to +70 °C
  - Installation: -20 °C to +60 °C
- Fast Connect can be stripped
- Permissible line length: max. 100 m (acc. to AWG 22)
- Drag-chain capable of following properties:
  - Bending radius for repeated usage: 49 mm
  - Bending radius for single usage: 19,5 mm



PROFINET cable Cat 5, solid

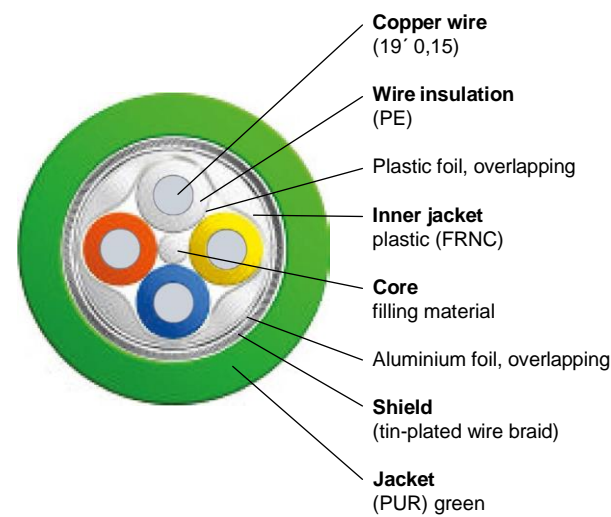

Engineering drawing

Odering details	Art. No.
PROFINET cable Cat 5, solid*	114050001

\*) length on request

### PROFINET cable Cat 5, drag-chain capable

#### Function

For a PROFINET network in an industrial environment only shielded cabling and connecting elements are permissible. Industry-suitable cables can be exposed to extremely mechanical load requiring a special structure. Plug-and-socket connectors and cables from a well-coordinated system. Only those elements that have proven their compatibility are called PROFINET units.

#### Wires

- copper strand: 19' 0,15 / Ø 0,75 mm
- PE insulation: Ø 1,5 mm
- wire colors: yellow, orange, white, blue

#### Shielding

- Shield braid made of tinned copper wires
- Aluminum foil overlapping

#### Electrical properties

- Damping factor per length
  - at 10 MHz: 6,0 dB / 100 m
  - at 100 MHz: 22 dB / 100 m
- Loop resistance per length: 120 Ohm
- Insulation resistance coefficient: 500 MOhm \* km
- Surge impedance
  - at 1 Mhz to 100 MHz: 100 Ohm
- Coupling resistance
  - at 10 MHz: 10 mOhm / m
- Near-end cross-talk attenuation per length
  - at 1 MHz to 100 MHz: 50 dB / 100 m

#### Mechanical data

- Outside diameter of
  - inner conductor: 0,75 mm
  - core insulation: 1,5 mm
  - inner sheath of cable: 3,9 mm
  - cable sheath: 6,5 mm
- Flameproof: IEC 60332-1
- Halogen-free: Yes
- Silicon-free: Yes
- Chemical resistance to mineral oil: resistant
- Radiological resistance to UV radiation: resistant
- Admissible pull: 150 N
- Permissible temperature range during
  - Operation/transport/Storage: -40 °C to +70 °C
  - Installation: -20 °C to +60 °C
- Fast Connect can be stripped
- Permissible line length: max. 100 m (acc. to AWG 22)
- Drag-chain capable of following properties:
  - Bending radius for repeated usage: 49 mm
  - Bending radius for single usage: 19,5 mm
- Number of bending cycles: 4000000

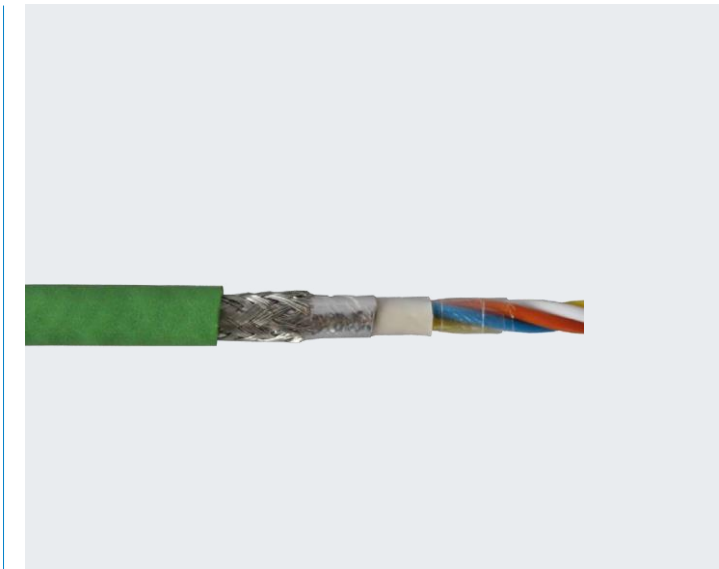

PROFINET cable Cat 5, drag-chain capable

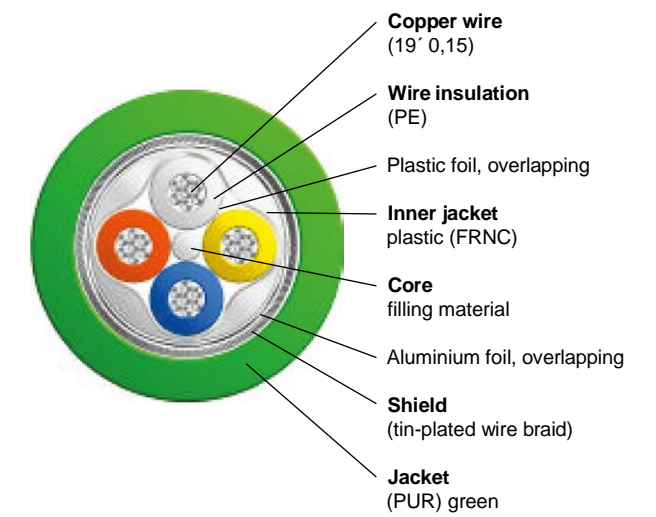

Engineering drawing

Odering details	Art. No.
PROFINET cable Cat 5, drag-chain capable	114070001

\*) length on request

**PROFINET cable assemblies**

**Function**

Because of the line construction industrial **PROFINET cables** are clearly more robust and safe when it comes to data communication. Since a large range of line and plug-type connectors is available, Indu-Sol provides a product range that meets the individual customer and application needs.

**Cable design**

- Solid
  - Jacket material: PVC
  - Conductor cross section: 4 cores AWG 22/1
  - Operating temperature: -40 °C to +70 °C
  - Colour: green
- Flexible
  - Jacket material: PVC
  - Conductor cross section: 4 cores AWG 22/7
  - Operating temperature: -40 °C to +70 °C
  - Colour: green
- Schleppkettentauglich
  - Jacket material: PUR
  - Conductor cross section: 4 cores AWG 22/7
  - Operating temperature: -40 °C to +70 °C
  - Colour: green
- Outdoor
  - Jacket material: PVC
  - Conductor cross section: 4 cores AWG 22/7
  - Operating temperature: -45 °C to +60 °C
  - Colour: black

**Ordering instruction**

**Cable end 1**

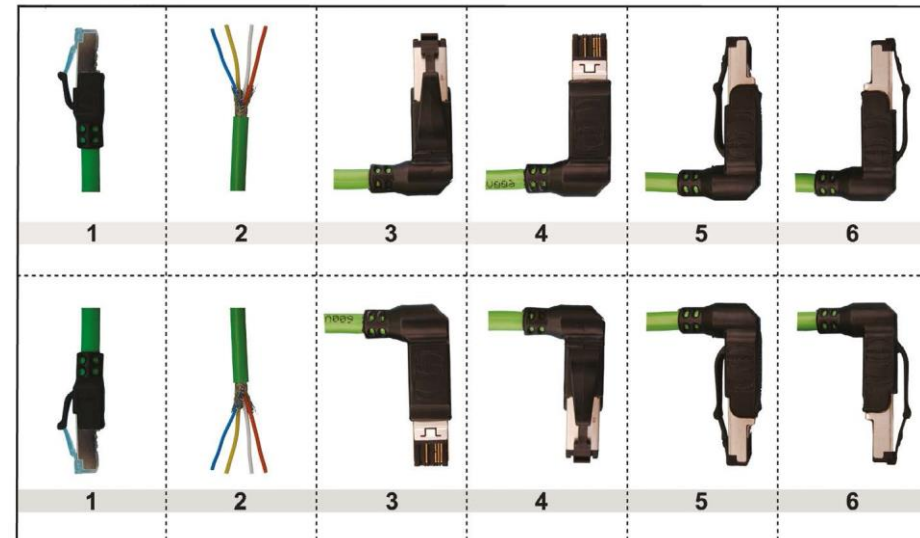

**Cable end 2**

**Wiring**

- 4-pin, 1:1 (RJ45 contacts 1/2 and 3/6)

**Shielding**

- S/FTP (full shielding + core shielding)

**Baud rate**

- 10 / 100 Mbps

**Sortimentvielfalt**

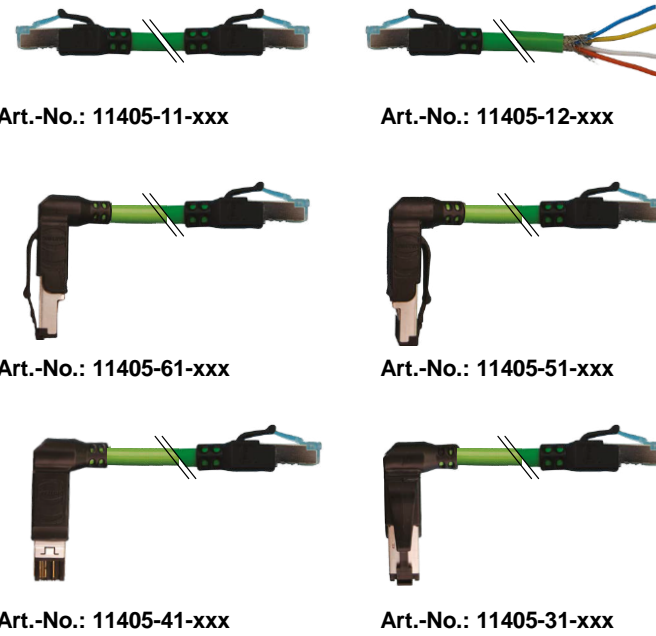

**-xxx (The line length is to be added to the article No. in purchase orders)**

**Cable length** (indicate in meters, without unit)

- Solid  
Article No.: 020516 - x x - xxx
- Flexible  
Article No.: 020517 - x x - xxx
- Suitable for use with drag chains  
Article No.: 020518 - x x - xxx
- Outdoor  
Article No.: 020519 - x x - xxx

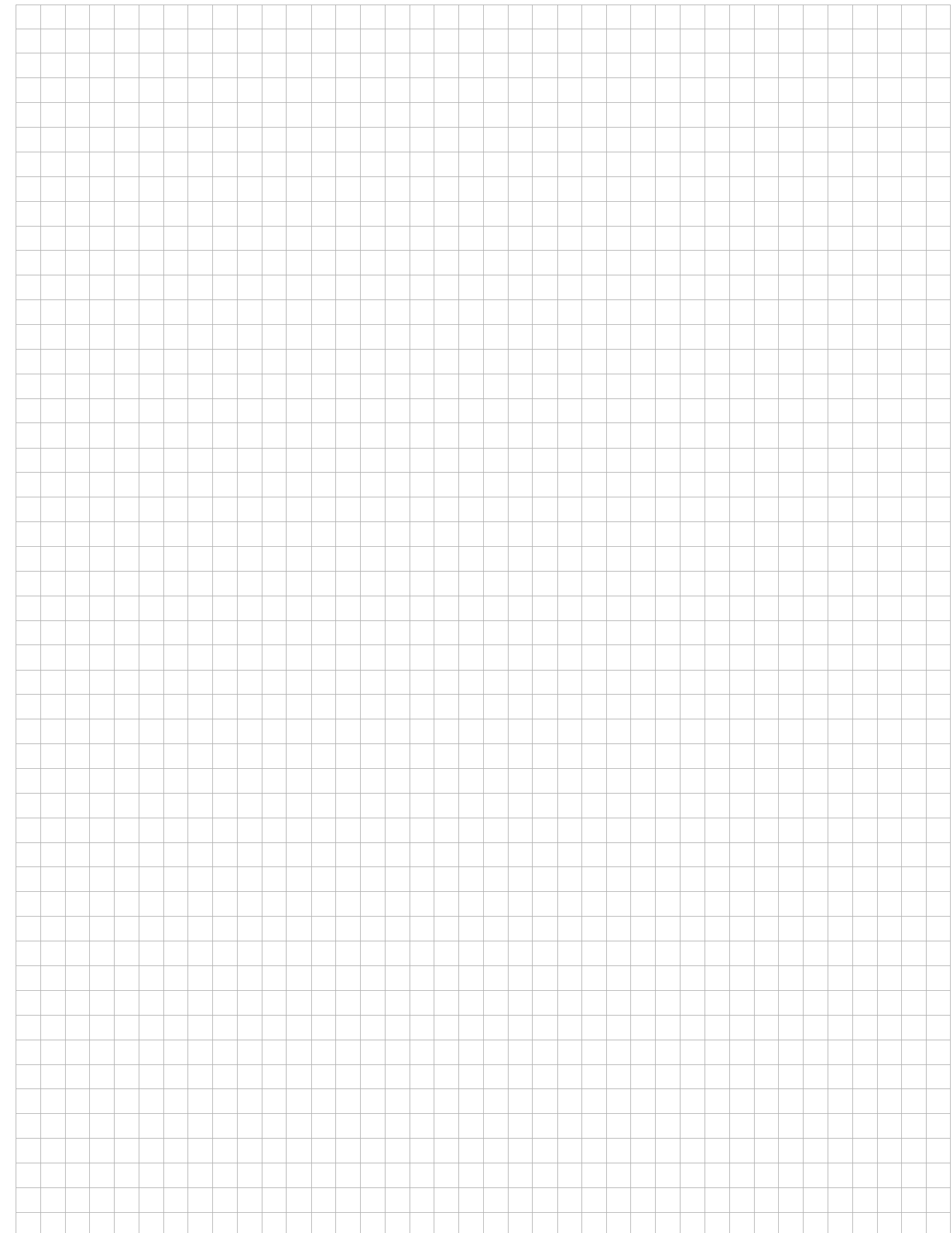

## Connectors RJ45 Plug 180 / 90

### Function

The IE FC **RJ45 plugs** are used to establish straight 100 Mbps Ethernet connections up to 100m without patch technology. By exchanging transmission/reception pairs in one plug it is also possible to establish crossed lines.

When the housing is open the colour coding on the contact cover makes it easier to connect the wires to the insulation displacement connectors. Through the transparent plastic material of the contact cover the user can easily check its own contacting.

### Application

An industrial Ethernet fast-connect line can thus be optimally connected to terminal devices and network components. The plugs have a rugged, industrial-suited metal housing protecting the data communication against disturbances in an optimal manner.

Four insulation displacement connectors make the contacting of the FC line types easy and safe. After the stripped wire end has been inserted in the folded up insulation displacement connectors the latter are pressed down for a safe contacting of the conductors.

Thanks to the compact design the connectors (IE FC Lug 180°) can be used both for single-socket and multi-socket (blocks) devices

### Technical data RJ45 Plug 180 2x2

- Number of electrical connections: for IE FC TP Lines - 4 for network components/devices - 1
- Fast Connect: yes
- for IE FC TP-Lines: integr. insulation displacement contacts
- for Network/devices: RJ45-connector
- Transmission with Cat5e: 100 Mbps / 1000 Mbps
- Ambient temperature during Operation: -20°C to +70°C during storage: -40°C to +80°C during transport: -40°C to +80°C
- Permissible humidity: max. 95%
- Dimensions (H x W x D): 16 x 13,7 x 55mm
- Industrial protection: IP20

### Technical data RJ45 Plug 90 2x2

- Number of electrical connections: for IE FC TP-Lines - 4 for network components/devices - 1
- Fast Connect: yes
- for IE FC TP-Lines: integr. insulation displacement contacts
- for Network/devices: RJ45-connector
- Transmission with Cat5e: 100 Mbps
- Ambient temperature during Operation: -20°C to +70°C during storage: -40°C to +80°C during transport: -40°C to +80°C
- Permissible humidity: max. 95%
- Dimensions (H x W x D): 16 x 13,7 x 42 mm
- Industrial protection: IP20

Odering details	Art. No.
RJ45 Plug 180 2x2	114030000
RJ45 Plug 180 4x2	112030000
RJ45 Plug 90 2x2	114030001



RJ45 Plug 180 2x2 / 4x2



RJ45 Plug 90 2x2

### CE mark

Plugs are passive components and are not subject to the CE mark system pursuant to EU Directives.

## Connectors RJ45 / M12 to assemble

### Function

For PROFINET networks it has become usual to use two kinds of faces (RJ45, M12). The most well known connector type RJ45 is available as IP20 solution for use in switchgear cabinets.

For IP 65/67 applications 4-pin M12 connectors with D coding are used. The PROFINET installation line (AWG22) can be connected to all other connectors.

All connectors used for PROFINET are shielded and laid out for rough industrial applications.

### Technical data

- Transmission characteristic: RJ45 / 4 A - CAT 5e RJ45 / 8 A - CAT 5e M12 - CAT 5
- Pin configuration agree with PROFINET
- Geometry: RJ45 / M12
- Industrial protection: RJ45 - IP20 M12 - IP67
- Wire diameter: AWG 22 to 24 flexible AWG 22 to 23 solid max. 1,6 mm Ø
- Wire insulation: max. 1,6 mm Ø
- Operating temperature: RJ45 -20 °C to +70 °C M12 -25 °C to +85 °C
- Cable jacket diameter: RJ45/4A 6,5 mm to 6,9 mm RJ45/8A 4,5 mm to 8,0 mm M12 5,5 mm to 7,2 mm
- Connector cycle: RJ45/4A min. 750 RJ45/8A min. 1000
- Casing material: RJ45 cast metal RJ45 plastic M12 cast metal

### Pin assignment

Signal	denotation	Wire colour	configuration	
			RJ45	M12
TD+	Transmission Data +	yellow	1	1
TD-	Transmission Data -	orange	2	3
RD+	Receive Data +	white	3	2
RD-	Receive Data -	blue	6	4

### CE mark

Plugs are passive components and are not subject to the CE mark system pursuant to EU Directives.

Odering details	Art. No.
Connectors RJ45 metal	112030003
Connectors RJ45 plastic	112030004
Plug M12	112030002
Socket M12	112030001



Ethernet / PROFINET Connector RJ45 metal

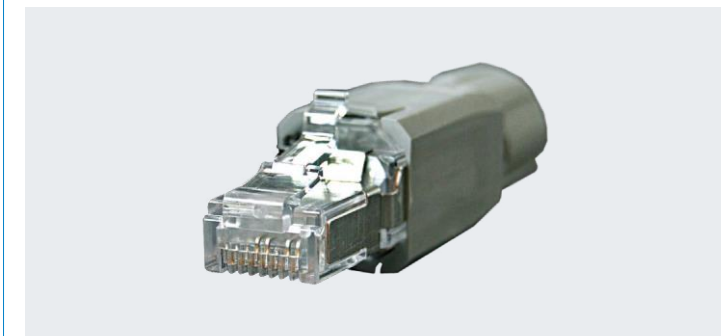

Ethernet Connector RJ45 plastic

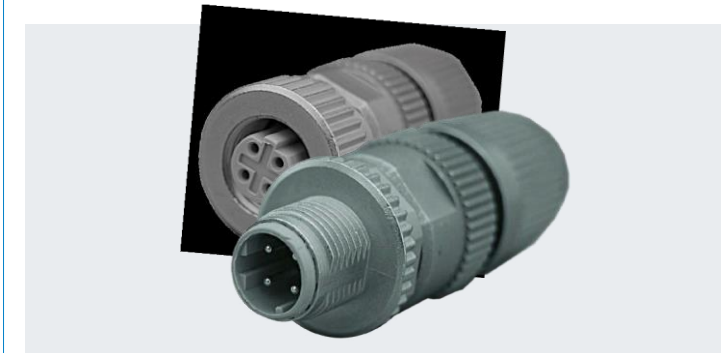

Ethernet / PROFINET M12 circular connector Fast Connect

M12x1 connector

M12x1 socket

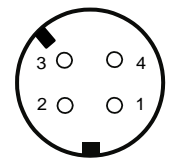
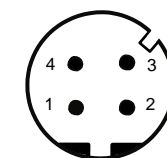

Pin assignment (see the left table)

### Round plug connector IE Fast Connect Plug PRO M12 (D-coded)

#### Use

The customizable connectors are used to connect the Ethernet and PROFINET cable to the device or as coupling in rough environments.

#### How to use

The customizable M12x1 connectors permit an easy on-site assembly. The connectors for Ethernet / PROFINET are 4-pole types, D-coded. The shield is contacted through the connector housing. The connectors have a shielded metal housing.

#### Bus connection

- M12 (D-coded)
- Fast Connect
- Axial or 90° cable outlet
- Transfer speed: 9,6 kbps to 12 Mbps

#### Electrical parameters

- Transfer speed: 10 / 100 Mbps
- Number of electrical connections: for IE FC TP Lines - 4  
for Network components - 1  
for Devices - 1
- Electrical connections: for IE FC TP integrated insulation displacement contacts for 4-wire TP FC installation lines  
for Network components or devices - M12 connector (D-coded)

#### Ambient conditions

- Operating temperature: -40°C to +85°C
- Protection type: IP65/67 when connected and screwed (DIN VDE 0470)

#### Constructive design

- Weight: 40 g
- Housing: Metal
- Dimensions (WxHxD): 19 x 19 x 73 mm
- Contact surface: Brass alloy (CuSnZn)
- Connection cross-section: max. 0.75 mm<sup>2</sup>

#### CE mark

Plugs are passive components and are not subject to the CE mark system pursuant to EU Directives.



Circular connector IE Fast Connect Plug PRO M12 (D-coded)



Sample application (side view)



Sample application (view from above)

M12x1 connector

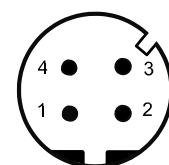

Signal	denotation	Wire colour	configuration	
			RJ45	M12
TD+	Transmission Data +	yellow	1	1
TD-	Transmission Data -	orange	2	3
RD+	Receive Data +	white	3	2
RD-	Receive Data -	blue	6	4

Pin assignment

### 3. Infrastructure components

sheet

#### ASi

##### Measuring point

- Active measuring point ASiMA HS IP67 126
- Active measuring point ASiMA IP67 127

##### Power packs

- ASi power packs 4A / 4Ae / 8A 128

##### Line insulation monitor

- ASi line insulation monitor 129

##### Repeater

- ASi repeater IP20 130
- ASi tuner incl. bus termination 131

##### Bus termination

- ASi plug 132

##### Cables

- ASi bus cable 133
- ASi power cable 134

Ordering details	Art. No.
Circular connector IE Fast Connect Plug PRO M12 (D-coded)	114030002

### Active measuring point ASiMA HS IP67

**Function**

The PG / Service interface is the feedback-free measuring point for measurements with ASi Scope and can also be used as programming interface.

The ASi measuring point is based on a reusable access technology according to IEC 60352-6 and can be used as distribution of connections or connector. Another advantage of the **ASiMA HS** is the tool-less mounting on the top-hat rail.

**Technical data**

- Voltage: max. 36 VDC
- Total current: max. 4 A
- Isolation voltage: ASi-Power: 200 V

**Contact assignment**

- Contact 1: ASi + (brown)
- Contact 2: 0 V (blue)
- Contact 3: ASi - (blue)
- Contact 4: +24 V (brown)
- Contact 5: not used

**General data**

- Protection type: IP67
- Mounting: to be snapped on top-hat rail or screwed
- Temperature range: -20 to +60 °C (storage temperature -40 to +80 °C)
- Dimensions (HxWxD): 90 x 60 x 40 mm



Active measuring point ASiMA HS

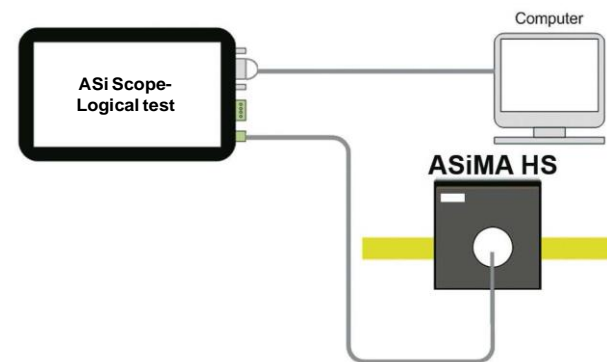

Example of connection

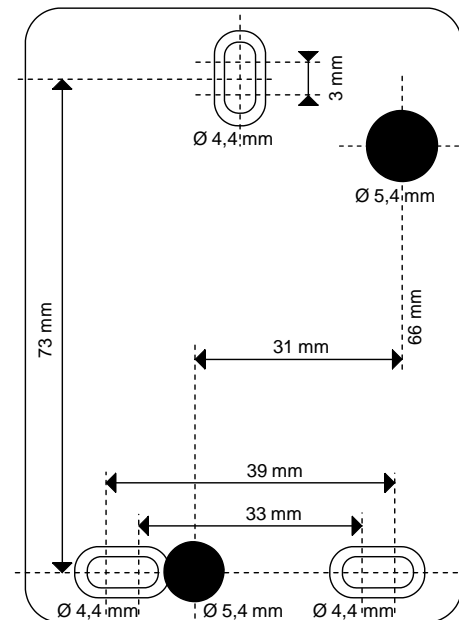

Engineering drawing

Odering details	Art. No.
Active measuring point ASiMA HS	120040001

### Active measuring point ASiMA IP67

**Function**

The PG / Service interface is the feedback-free measuring point for measurements with ASi Scope and can also be used as programming interface.

The ASi **measuring point** is based on a reusable access technology according to IEC 60352-6 and can be used as distribution of connections or connector. The ASi connector 0911 ANC 406 is included in the scope of supply.

**General Data**

- product features: Oil resistance, vibration consistency
- Protective system: IP67
- Casing: PA
- Rated voltage at 40 °C: 4 A



Active measuring point ASiMA

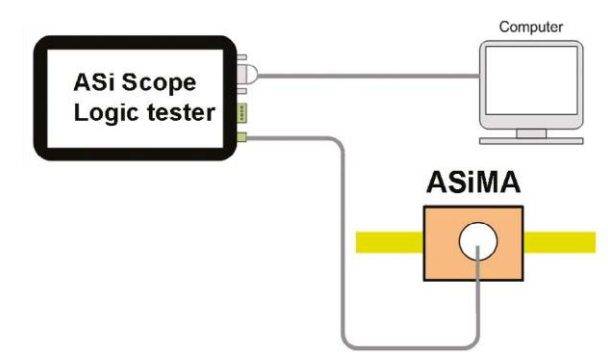

Example of connection

Odering details	Art. No.
Active measuring point ASiMA	120040000



### ASi power pack 4A / 4Ae / 8A

#### Function

The primary switched power supply is designed for field bus applications transporting energy and data at the same time via a two-wire line. The **power pack** for the ASi supplies a completely removed ASi system with an output current of 4 A and 8 A respectively. The sinusoidal current drain from the network avoids the formation of harmonics. In addition to energy supply the **power pack** has the function of data disconnection to the supply source and balancing of the two ASi output lines towards the machine mass (shield).

Because of the exact and transformer coupling unshielded load lines can be used.

#### Technical data

	4A	8A
<b>Input</b>		
Power factor	approx. 0,6 (according to input voltage)	
Input frequency	47 - 63 Hz	
Efficiency	approx. 90%	
Voltage range	90 - 265V AC	115/230V AC
Input current	without idle current at 230V DC	
	approx. 0,6A	approx. 1,2A
Input fuse	electronic fuse against external short circuits internal fuse	
<b>Output</b>		
Output Voltage	29,5V - 31,6V DC	
Remaining ripple	according to ASi-Specification	
Output current	4A	8A
Current limitation	ca. 4,5A	ca. 8,5A
<b>Display</b>		
LED green (PWR)	power on (at frontside)	
LED red (Overload)	overload error (at frontside)	
<b>Standard conformity</b>		
Standard	EN 60 950, UL 60 950	
Operating temp.	-10 °C ... +55 °C	
Storage temperture	-40 °C ... +85 °C	
Dimensions (LxWxH)	126 x 70 x 129 mm	141 x 70 x 151 mm



ASi power pack 4 A / 4 Ae / 8 A

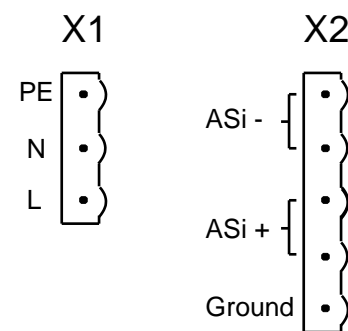

Pin assignment (ASi power pack 4A)

Odering details	Art. No.
ASi power pack 4 A	120060000
ASi power pack 4 Ae (integrated earth-leakage monitor)	120060001
ASi-Netzteil 8 A	120060002

### ASi line insulation monitor

#### Function

Due to the fact that current supply and information run through the ASi cables at the same time, body contact cannot be excluded that may lead to communication failures. To prevent this happening, the insulation monitor monitors the two lines for body contact and signals the same. Both non-symmetrical and symmetrical insulation faults are detected.

#### Technical data

- Connections: screw terminals up to 0.75 mm<sup>2</sup>
- Supply voltage: 26.5 to 31.6 VDC
- Operating current: < 40 mA
- Number of required ASi power packs: none
- Display (2 LEDs): LED yellow - function LED green - operation
- Operating temperature: -25 °C to 60 °C
- Storage temperature: -40 °C to 70 °C
- Industrial protection: IP20
- Insulation voltage: EN 61557-8 (1997) EN 61326/A2 (2001)
- Dimensions (H x W x D): 74 x 22 x 110 mm

#### Note

The application range is limited to isolation monitoring in non-earthed ASi and 24 DC voltage networks (IT system). Active symmetrical and passive measuring technique, 2 signalling contacts. Contact 11/24 is triggered by symmetrical faults and asymmetrical faults. Contact 11/14 is triggered additionally by asymmetrical faults. The contacts are closed when the ASi voltage is applied and there is no fault.



ASi line insulation monitor

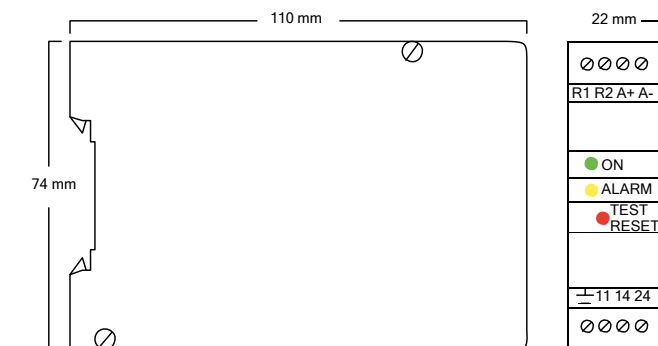

Engineering drawing

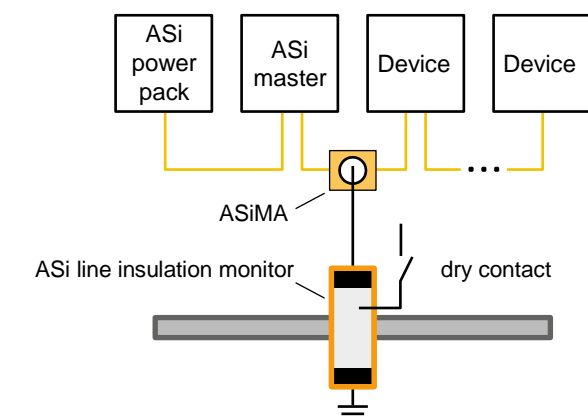

Example of connection

Odering details	Art. No.
ASi line insulation monitor	120070001

### ASi repeater IP20

#### Function

The **ASi repeater** with local diagnosis indicates separately ASi communication faults in addition to the voltage supply. The red ASi Fault-LED lights up as long as no ASi communication takes place. The communication fault LED helps the user to detect basic installation problems within a short period of time. The new ASi repeaters are compatible with all ASi repeaters available on the market. Especially the IP 20 ASi repeaters can be easily installed in control cabinets or primary switchgear cabinets together with the ASi power pack.

#### Application

The ASi bus permits a maximum line length of 100 m (incl. all spur lines). If this length is reached, a repeater has to be installed. The installation of the ASi repeater requires another power pack to be installed in the newly created ASi segment (see installation drawing).

#### Technical data

- Connections: Combicon clamp-type terminals
- Supply voltage: Operating voltage form ASi
- Operating current: 60 mA (per phase segment), 120 mA (total)
- Number of necessary ASi power packs: one additional power pack (as with every ASi repeater)
- Display (4 LEDs):
  1. PWR1 ASi-Power circuit 1
  2. FAULT1 ASi communication fault
- circuit 1
  3. PWR2 ASi-Power circuit 2
  4. FAULT2 ASi communication fault circuit 2
- Insulation voltage:  $\geq 500$  V  
EMC acc. to EN61000-6-3, EN61000-6-2
- Dimensions (L x W x D): 114 x 25 x 1105 mm

#### Ambient conditions

- Operating temperature: 0 °C to +55 °C
- Storage temperature: -25 °C to +75 °C
- Industrial protection: EN 60529 IP20

#### Note

The ASi repeater takes no slave address. The total number of slaves (31 and 62 resp. per master phase remains unchanged. No parameterization is required. For the segment created when the repeater is installed an additional power pack will be needed.



ASi repeater IP20

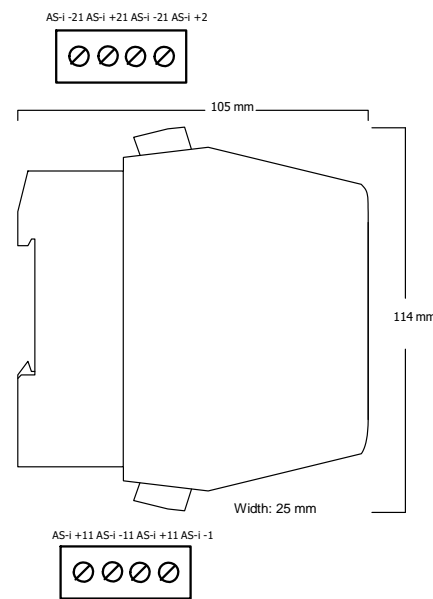

Engineering drawing

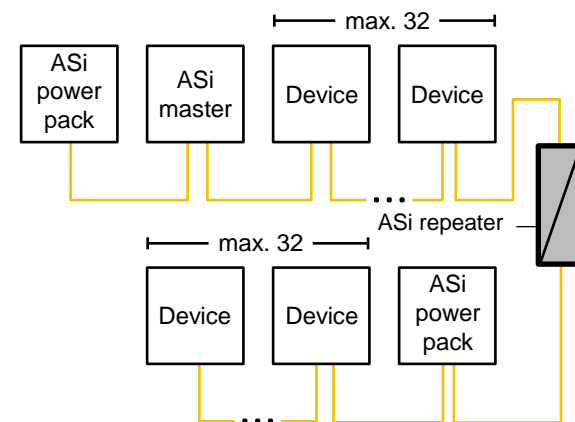

Example of connection

Odering details	Art. No.
ASi repeater IP20	120070005

### ASi tuner incl. bus termination

#### Function

The primary task of the **ASi tuner** is the length adjustment in the ASi networks without repeater. The ASi tuner can be completely switched off by a switch or set to a default. The ASi tuners provide for a stable communication in network of 300 m in length without the need of a repeater and additional power pack. This means a triplication of the ASi line lengths.

#### Technical data

- Connections: ASi ribbon cable / ASi round cable
- Supply voltage: ASi (30 VDC)
- Operating current: 60 mA
- Display (5 LEDs):
  - LED-Power green voltage OK
  - LED green tuning active
  - LED red fault (ASi analyzer)
  - LED yellow warning (ASi analyzer)
  - LED green fault (ASi analyzer)
- EMC: EMC acc. to EN61000-6-3, EN61000-6-2
- Dimensions (H x W x D): 80 x 90 x 43 mm

#### Ambient conditions

- Operating temperature: 0 °C to +55 °C
- Storage temperature: -25 °C to +75 °C
- Industrial protection: IP65

#### Meaning of LED

- Description
  - red = severe fault
  - yellow = frequent repeats that should be clarified depending on application
  - green = almost repeat-free communication
- Display (5 LEDs):
  - LED-Power lights green = voltage OK
  - LED-Power is flashing = voltage is low
  - LED Green is on = communication is OK (ASi analyzer)
  - LED ERROR lights red = failure (ASi analyzer)
  - LED WARNING lights yellow = warning (ASi analyzer)



ASi tuner

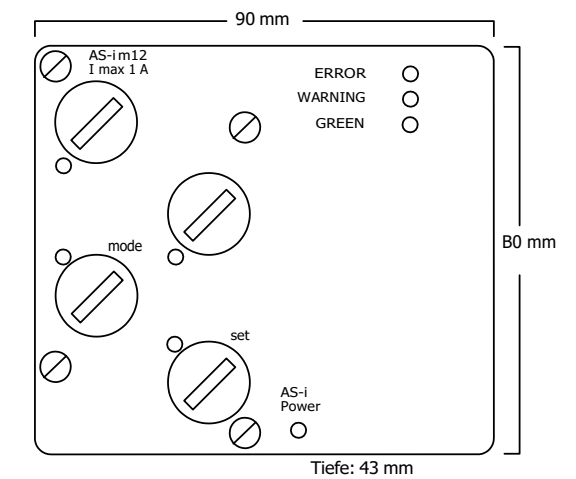

Engineering drawing

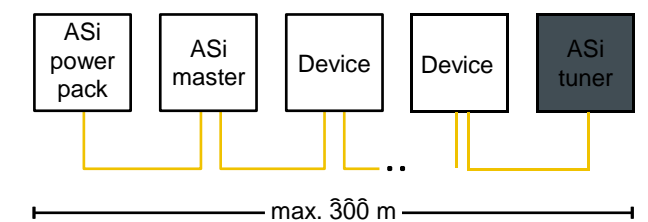

Example of connection

Odering details	Art. No.
ASi tuner	120070000

### ASi plug

**Function**

The ASi bus termination allows a doubling of the ASi line length. The passive bus termination allows a line extension up to about 200 m. It is installed at the end of a line. The system will thus become more flexible.

**Technical data**

- Connections: ASi circular plugs
- Supply voltage: ASi (30 VDC)
- Operating current: 10 mA
- Display (2 LEDs): LED green ASi voltage > 26 V  
LED yellow ASi voltage > 18.5 V
- Dimensions (H x W x D): 19 x 47 mm

**Ambient conditions**

- Operating temperature: 0 °C to +55 °C
- Storage temperature: -25 °C to +75 °C
- Industrial protection: IP65



ASi plug

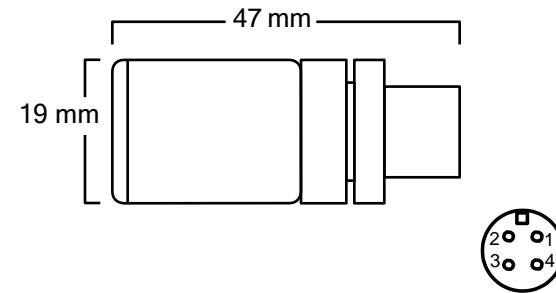

Engineering drawing ASi plug

### ASi plug 2

**Function**

The **ASi plug 2** is a slave for the field bus system AS interface. On the one hand it allows to double the ASi line length up to about 200 m and on the other to monitor the supply voltage. The ASi Z plug AI010 serves also to monitor the supply voltage: if the AS-Interface supply voltage is lying within the specified band, the inputs D2 and D3 are set. If the supply voltage is falling under the specified limit the inputs will be reset. A network supply voltage monitoring is realized.

The ASi bus termination is installed at the end of a line and provides for a greater flexibility of the system.

**Technical data**

- Connections: ASi circular plugs
- Supply voltage: ASi (20-31,6 VDC)
- Operating current: <=18 mA
- Display (2 LEDs): LED green ASi voltage > 26 V  
LED yellow ASi voltage > 18,5 V
- Dimensions (H x W x D): 20 x 55 mm

**Ambient conditions**

- Operating temperature: 0 °C to +55 °C
- Storage temperature: -25 °C to +70 °C
- Industrial protection: IP67

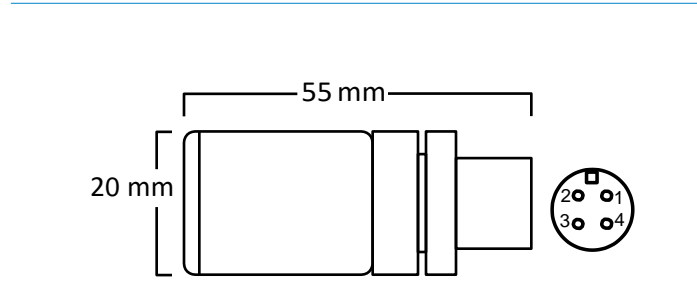

Engineering drawing ASi plug 2

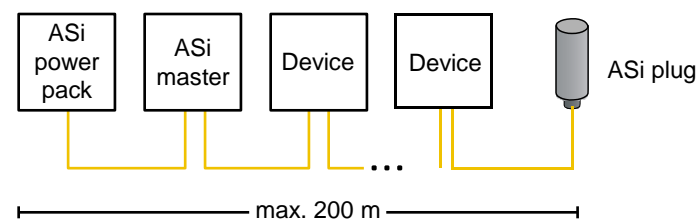

Odering details	Art. No.
ASi plug	12007003

### ASi bus cable

**Function**

The **ASi bus cable** is a two-core, flat fieldbus line for AS interface (Actuator-Sensor Interface) and network systems of the lower field range. The data for ASi slaves, masters, repeaters, extenders and sensors are transferred through the unshielded, geometrically coded two-wire flat line. The contacting of the conductors is rendered without stripping by means of access technology of the ASi modules. The line is suitable for permanent installation and flexible use in rooms.

**Electrical parameters**

- Surge impedance at 167 kHz: 70 - 140 Ohm
- Conductor resistance acc. to VDE 0295 in max.: 27.4 Ohm / km
- Capacity in max.: 80 nF / km
- Inductivity in: 0.5 to 0.75 mH / km
- Volume resistivity: min. 10 Ohm x cm

**Design**

- Conductor: copper litz wire, tin-plated, 2 x 1.5 mm<sup>2</sup>, extra finely stranded acc. to VDE 0295, class 6
- Single-wire diameter: 0.16 mm.
- Insulating cover: rubber mixture EM3 acc. to DIN VDE 0207, Part 21, wall thickness 0.5 mm, core diameter: 2.5 mm sheath colour yellow, RAL 1012 sheath colour black, RAL 9005
- Core arrangement: 2 cores in parallel, brown core arranged at the profile nose side

**Mechanical and technical properties**

- Operating temperature: moved: -30 °C to 85 °C  
perman. laid: -40 °C to 85 °C
- Min. bending radius: moved: 3 x line diameter  
perm. laid: 6 x line diameter
- Burning behaviour: flame retardant based on IEC 707 VDE 0304, Part 3 FH 2-25
- Allowable pulling force for laying: max. 150 N

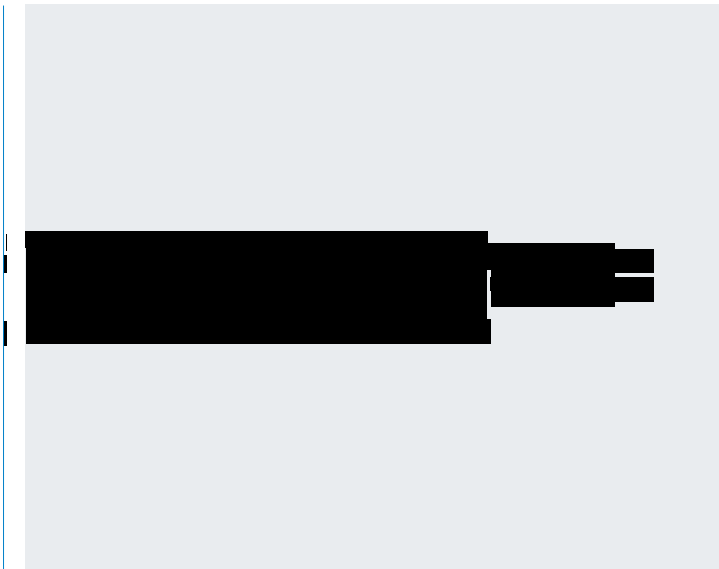

ASi bus cable

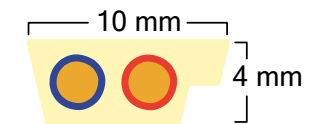

Engineering drawing

Odering details	Art. No.
-----------------	----------

**ASi power cable**

**Function**

**ASi power cables** have been specifically developed for industrial automation equipment to supply components, such as pushbuttons, sensors etc. with auxiliary power. The polarity cannot be exchanged because of the cable structure. Thus, the ASi power cable can be easily and safely connected to the slave interfaces.

**Electrical parameters**

- Line resistance: 13.7 Ohm / km
- Insulation resistance: 1 MOhm / km
- Operating voltage: max. 300 V

**Design**

- Conductor: copper litz wire tin-plated, stranded  
8.4 x 0.15, dia.: 2.5 mm
- Sheath: thermoplastic elastomer (TPE)
- Colour: black
- Insulating covering: TPE insulation  
wall thickness: approx. 0.5 mm  
core diameter: 2.5 mm

**Mechanical and technical properties**

- Burning behaviour: flame-retardant acc. to IEC 60332-1-2
- Oil resistance: oil and cutting oil resistant
- Cold bending resistant: depending on IEC 60811-1-4

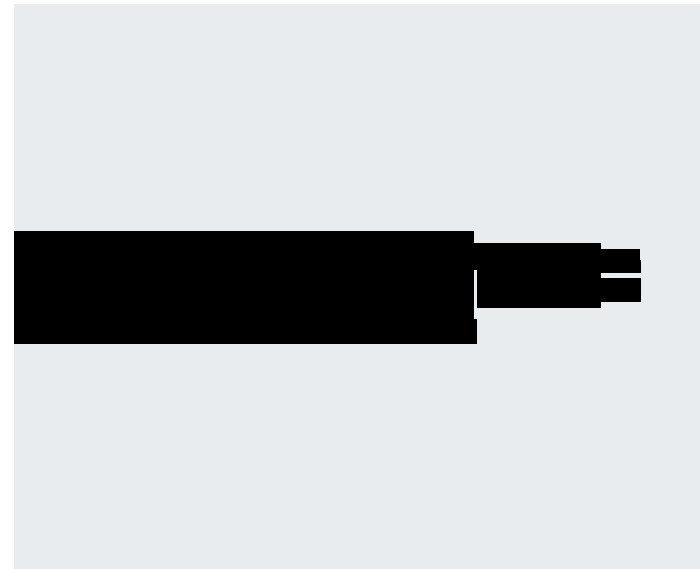

ASi power cable

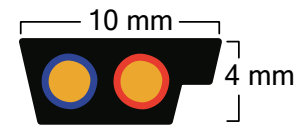

Engineering drawing

**3. Infrastructure components**

sheet

**CAN, DeviceNet, SafetyBUS p**

**Measuring points**

136

Active measuring point CBMA IP67

136

Active measuring point DNMA IP68

137

**Connectors**

138

Circular connector M12 (A-coded)

138

Connector PG/90° screw terminal for CAN

139

Connector screw terminal axial

140

Connector PG/90° screw terminal for SafetyBUS p

141

Connector PG/90° Fast Connect

142

**Repeater**

143

CANbridge

143

**Kabel**

144

CAN-Bus-line

144

Odering details	Art. No.
ASi power cable	120050001

### Active measuring point CBMA IP67

#### Function

To determine physically the signal-to-noise ratio of the CAN-/CANopen communication, it is necessary to provide a feedback-free **measuring point CBMA** in every master system at the segment ends each. The diagnostic tools are connected via the M 12 measuring socket provided at the CBMA.

#### Bus connection

- M12 (5-pin)

#### Measuring sockets

- M12 (5-pin)

#### Technical data

- CAN-applications: CAN, CANopen, DeviceNet, SafetyBUS p
- Baud rate: 9,6 kBps to 1 MBps
- Dimensions (H x W x D)  
T-piece: 45 x 57 x 16,5 mm  
terminator socket: 56 x 15 x 15 mm
- Casing: plastic
- Fastening: bore holes (Ø 5mm)

#### Ambient conditions

- Operating temperature: -40 °C to +80 °C
- Industrial protection: IP67



CBMA

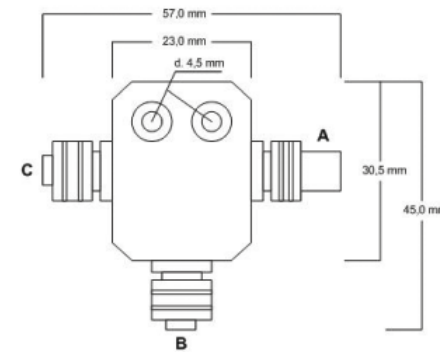

Engineering drawing

<b>A</b>	Bus „in“	Socket	<ul style="list-style-type: none"> <li>1: Shield</li> <li>2: V+ (red)</li> <li>3: V- (black)</li> <li>4: CAN_H (white)</li> <li>5: CAN_L (blue)</li> </ul>
<b>B</b>	Diagnosis/ Programming interface	Pin	<ul style="list-style-type: none"> <li>1: Shield</li> <li>2: V+ (red)</li> <li>3: V- (black)</li> <li>4: CAN_H (white)</li> <li>5: CAN_L (blue)</li> </ul>
<b>C</b>	Bus „out“/ Terminating resistor	Pin	<ul style="list-style-type: none"> <li>1: Shield</li> <li>2: V+ (red)</li> <li>3: V- (black)</li> <li>4: CAN_H (white)</li> <li>5: CAN_L (blue)</li> </ul>

Pin assignment

#### Ordering details

**CBMA - Set**      **Art. No. 119040001**

The CBMA set covers (pre-assembled ready for installation):

- 1 x active measuring adapter „CBMA“
- 1 x one-sided precut CAN bus line 1.5 m
- 1 x M12 bus termination
- 1 x M12 blind plug

**CBMA - single**      **Art. No. 119040000**

<b>Ordering details</b>	<b>Art. No.</b>
<b>Active measuring point DNMA 7/8“</b>	<b>119040002</b>
<b>Active measuring point DNMA M12</b>	<b>119040003</b>

### Active measuring point DNMA IP68

#### Function

To determine physically the signal-to-noise ratio of the DeviceNet communication, it is necessary to provide a feedback-free **measuring point DNMA** in every master system at the segment ends each. The diagnostic tools are connected via the M 12 or 7/8" measuring socket provided at the DNMA.

#### Bus connection

- 7/8" (5-pin)

#### Measuring sockets

- M12 (5-pin)
- 7/8" (5-pin)

#### Electrical parameters

- Current carrying capacity 8 A (thick)  
4 A (thin)
- Operating voltage: 30 VAC  
36 VDC

#### Ambient conditions

- Operating temperature: -40 °C to +90 °C
- Industrial protection: IP68 (Nema 6P)

#### Design

- Dimensions (H x W x D): approx. 65 x 94 x 29 mm
- Casing: plastic
- Contact: CuZn, nickel sublayer and gold-plated acc. to DeviceNet specification
- Fastening: bore holes (Ø 5mm)



DNMA

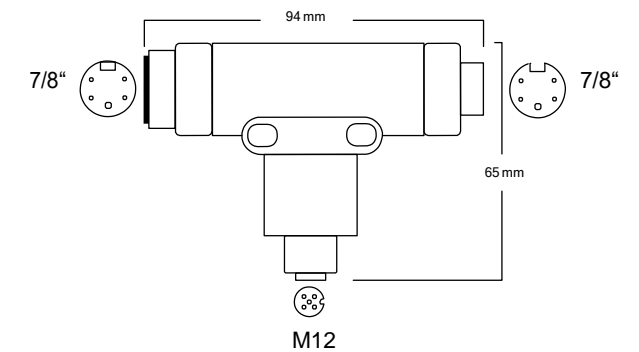

Engineering drawing

<b>M12</b>	<ul style="list-style-type: none"> <li>1 = Drain</li> <li>2 = +24V</li> <li>3 = GND</li> <li>4 = CAN High</li> <li>5 = CAN Low</li> </ul>
<b>7/8"</b>	<ul style="list-style-type: none"> <li>1 = Drain</li> <li>2 = +24V</li> <li>3 = GND</li> <li>4 = CAN High</li> <li>5 = CAN Low</li> </ul>

Pin assignment

### Circular connector M12 (A-coded)

#### Function

The convertible plug-and-socket connector (straight, angled) is used for connecting the cable to the CAN users in extremely rough conditions.

#### Application instruction

The convertible plug-and-socket M12x1 connector allows for an easy on-site installation. The plug-and-socket connectors have a brass casing that can be shielded.

#### Bus connection

- M12 (A-coded)
- Screw terminal connection
- Axial or 90° cable outlet

#### Electrical parameters

- Rated current / contact: 4 A (IEC 60512- 3)
- Rated voltage / contact: 30 VAC, 36 VDC (VDC 0110)

#### Ambient conditions

- Operating temperature: -40 °C to +85 °C
- Industrial Protection: IP67 when plugged and screwed (EN 60529)

#### Design

- Weight: straight: 60 g  
angled: 68 g
- Casing: brass (CuZn), surface nickel-plated
- Contact surface: brass alloy (CuSnZn)
- Conductor size: max. 0,75 mm<sup>2</sup>

#### CE mark

Plugs are passive components and are not subject to the CE mark system pursuant to EU Directives.



Circular connector M12 (A-coded)



Connector angled



Exploded drawing

M12x1 socket

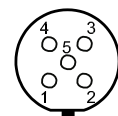

M12x1 dowel

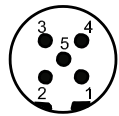

- Pin 1: Shield
- Pin 2: V+
- Pin 3: V-
- Pin 4: CAN High
- Pin 5: CAN Low

Pin assignment

Odering details	Art. No.
Circular connector M12 - connector straight	119030002
Circular connector M12 - socket straight	119030003
Circular connector M12 - connector angled	119030004
Circular connector M12 - socket angled	119030005

### Connector PG/90° screw terminal

#### Function

This connector PG/90° screw terminal allows for a quick and comfortable connection of incoming and outgoing bus lines. The connector contacts are routed on colour-labeled screw-type terminals. In position ON, the integrated terminating resistor switches off the outgoing segment. When using the screw terminal all commercially available line types can be connected.

#### Bus connection

- 9-pin sub-D interface
- Screw terminal connection
- 90° cable outlet

#### Electrical parameters

- Terminating resistor integrated, selectable from outside by switch
- Baud rate: up to 1.0 Mbps

#### Ambient conditions

- Operating temperature: 0 °C to +60 °C
- Transport / storage temperature: -25 °C to +75 °C
- Relative humidity: max. 75 % at a temperature of +25 °C
- Industrial protection: IP20

#### Design

- Dimensions (H x W x D): 17 x 40 x 65 mm
- Interface: 9-pin sub-D
- Weight: approx. 40 g
- Casing: plastic material metallized

#### Pin assignment

- A1 = CAN Low = Pin 2 sub-D
- B1 = CAN High = Pin 7 sub-D
- C1 = CAN GND = Pin 3 sub-D
- GND = Pin 6 sub-D
- CAN V+ = Pin 9 sub-D

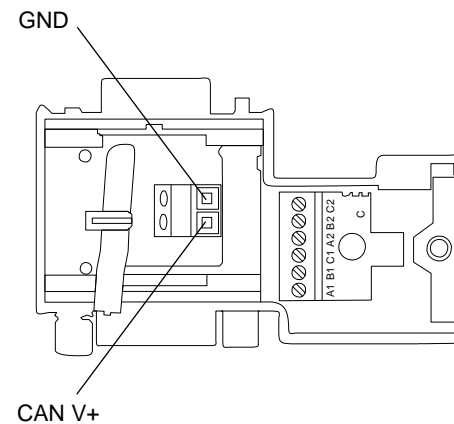

#### CE mark

Plugs are passive components and are not subject to the CE mark system pursuant to EU Directives.

Odering details	Art. No.
Connector PG/90° screw terminal	119030000



Connector PG/90° screw terminal

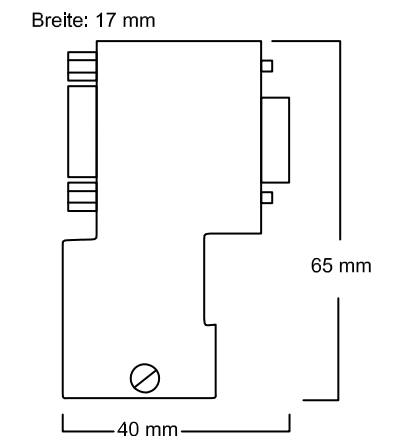

Engineering drawing

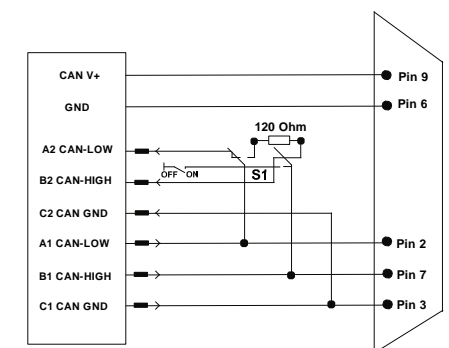

Functional diagram

### Connector screw terminal axial

#### Function

This **connector screw terminal axial** allows for a quick and comfortable connection of incoming and outgoing bus lines. The connector contacts are routed on colour-labeled screw-type terminals. In position ON, the integrated terminating resistor switches off the outgoing segment. When using the screw terminal all commercially available line types can be connected.

#### Bus connection

- 9-pin sub-D interface
- Screw terminal connection
- Axial cable outlet

#### Electrical parameters

- Terminating resistor integrated, selectable from outside by switch
- Baud rate: up to 1.0 Mbps

#### Ambient conditions

- Operating temperature: 0 °C to +60 °C
- Transport / storage temperature: -25 °C to +75 °C
- Relative humidity: max. 75 % at a temperature of +25 °C
- Industrial protection: IP20

#### Design

- Dimensions (H x W x D): 67,5 x 40 x 17 mm
- Interface: 9-pin sub-D
- Weight: approx. 40 g
- Casing: plastic material metallized

#### Pin assignment

- A1 = CAN Low = Pin 2 sub-D
- B1 = CAN High = Pin 7 sub-D
- C1 = CAN GND = Pin 3 sub-D

#### CE mark

Plugs are passive components and are not subject to the CE mark system pursuant to EU Directives.



Connector screw terminal axial

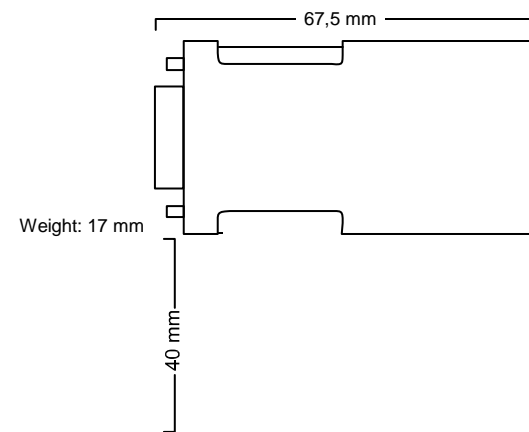

Engineering drawing

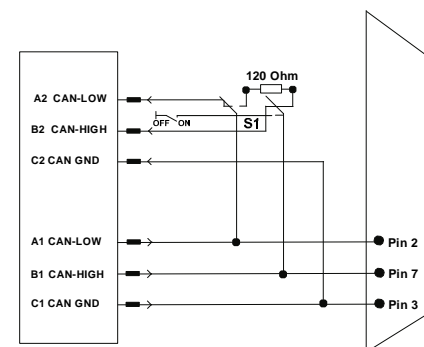

Functional diagram

### Connector PG/90° screw terminal

#### Function

The **connector PG/90° screw terminal** allows a quick and comfortable connection of incoming and continuing bus lines. The plug contacts are highlighted in colours on screw terminals. The terminating resistor is integrated and disconnects the outgoing segment in ON position. When using the screw terminal all commercially available line types can be connected.

#### Bus connection

- 9-pin sub-D interface
- Screw terminal connection
- 90° cable outlet

#### Electrical parameters

- Terminating resistor integrated, selectable from outside by switch
- Baud rate: up to 1.0 Mbps

#### Ambient conditions

- Operating temperature: -20 °C to +70 °C
- Industrial protection: IP20

#### Design

- Dimensions (H x W x D): 17 x 46 x 77 mm
- Interface: 9-pin sub-D
- Weight: approx. 40 g
- Casing: thermoplastic

#### Pin assignment

Pin	Denotation	Wire colour
1	V+	yellow
2	CAN-LOW	brown
3	CAN-GND	white
4	V-	grey
5	CAN-SHLD	
6	V-	grey
7	CAN-HIGH	green
8		
9	V+	yellow

#### CE mark:

Plugs are passive components and are not subject to the CE mark system pursuant to EU Directives.



Connector PG/90° screw terminal

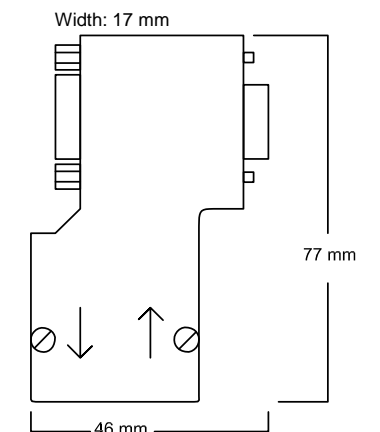

Engineering drawing

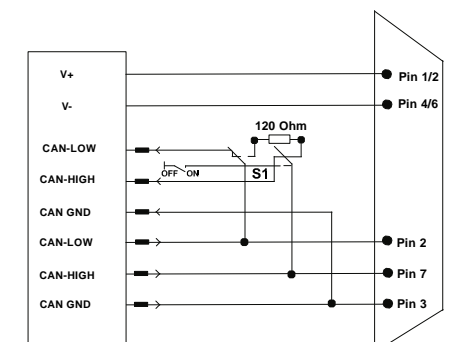

## Connector PG/90° Fast Connect

### Function

The **connector PG/90° Fast Connect** allows a quick and comfortable connection of incoming and continuing bus lines. The contacts are highlighted in colours on labelled contact clamps. The terminating resistor is integrated and disconnects the outgoing segment in ON position. The easy-to-install connection through an insulation piercing terminal requires a Fast Connect type of line construction.

### Bus connection

- 9-pin sub-D interface
- Insulation piercing terminal
- 90° cable outlet

### Electrical parameters

- Terminating resistor integrated, selectable from outside by switch
- Baud rate: up to 1.0 Mbps

### Ambient conditions

- Operating temperature: -25 °C to +70 °C
- Industrial protection: IP20

### Design

- Dimensions (H x W x D): 47 x 80 x 16 mm
- Interface: 9-pin sub-D
- Weight: approx. 40 g
- Casing: thermoplastic

### Pin assignment

Pin	Bezeichnung	Adernfarbe
1		
2	CAN-LOW	braun
3	CAN-GND	weiß
4		
5	CAN-SHLD	
6		
7	CAN-HIGH	grün
8		
9		

### CE mark

Plugs are passive components and are not subject to the CE mark system pursuant to EU Directives.

Ordering details	Art. No.
Connector PG/90° Fast Connect	119030007



Connector PG/90° Fast Connect

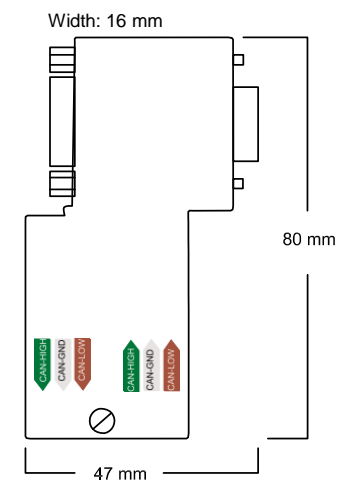

Engineering drawing

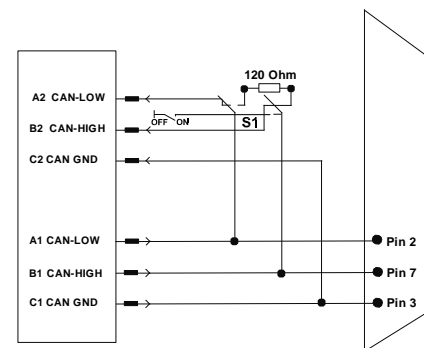

Functional diagram

## CANbridge

### Function

The **CANbridge** allows the coupling of two CAN networks that have different bit rates and frame formats (CAN 2.0 A or CAN 2.0 B). Adjustable filter and turnover rules provide for a controlled data traffic between the two CAN networks. It can be determined, for example, that only the necessary CAN information is to be transferred to the other CAN network which keeps the bus load low. Under consideration of the maximally possible line length per CAN network the CAN network can be extended by the CANbridge.

### Application instruction

The use of the CANbridge creates two galvanically isolated independent CAN networks and have to be regarded as independent of each other when it comes to their real-time behaviour. The two CAN networks have to be terminated at the CANbridge by a terminating resistor (120 Ohm each). For the purpose of diagnostic measurement measuring points should be available at the beginning and end of the two CAN networks. All settings to the CANbridge are made in an ASCII configuration file which is then transmitted by download to the CANbridge through a serial interface.

### Bus connection

The CAN bus is connected by the screw terminal to the upper side and underside respectively of the CANbridge and split into two independent CAN networks. The voltage is also supplied to the upper side of the CANbridge.

### Technical data

- Supply voltage: (rated voltage) 9 V - 36 V
- Wattage: approx. 1.5 W
- Baud rate: 20 kbps - 1 Mbps
- CAN controller: 2 x CAN on Chip, CAN2.0A, CAN2.0B
- CAN bus interface: 2 x ISO 11898-2 (high speed), galvanically isolated
- Serial interface: RS232
- Certifi: CE
- Casing: plastic top-hat rail
- Dimensions (H x W x D): 102 x 23 x 120 mm

### Ambient conditions

- Operating temperature: -20 °C to +70 °C
- Transport / storage temperature: -40 °C to +85 °C
- Relative humidity: 10 - 95 %, no moisture condensation
- Industrial protection: IP20

Ordering details	Art. No.
CANbridge	119040005



CANbridge

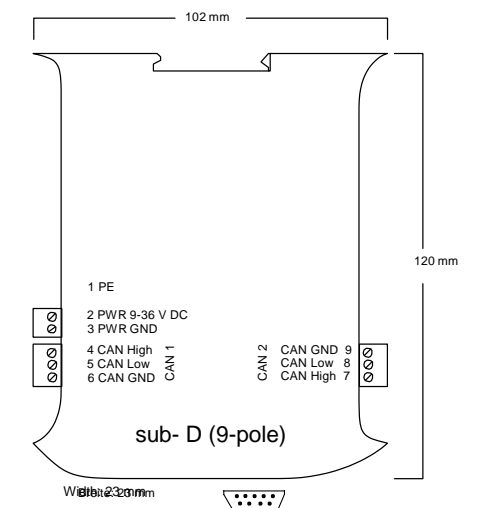

Engineering drawing



### CAN-Bus-line

#### Function

The two-pair CAN bus line is used to cable CAN bus systems in accordance with ISO 11898 with UL- and CSA approval and bus systems of 120 Ohm nominal impedance. The power supply of the bus logic can be rendered via the second pair in the cable. The transmission properties of the lines are CAN system-conforming and ensure a high data transmission security. The line is suitable for permanent and partly flexible installation in dry and wet rooms.

#### Electrical parameters

- Surge impedance: 120 Ohm
- Conductor resistance (loop): max. 115 Ohm/km
- Insulation resistance: min. 5 GOhm x km
- Coupling resistance (up to 30 MHz): max. 250 MOhm/m
- Effective capacitance (at 800Hz): max. 40 nF/km
- Working voltage peak: 250 V
- Test voltage: core/core: 1,500 V  
core/shield: 1,000 V

#### Design

- Conductor: Copper wire bright 0.34 mm<sup>2</sup>, 7-wire
- Insulating covering: cellular-PE or foam skin, core diameter: approx. 1.7 mm
- Core arrangement: 2 cores laid up as pair, 2 pairs laid up with two fillers for cable core assembly  
Pair 1: white and brown  
Pair 2: green and yellow
- Shield: braid made of tinned copper wires
- Sheath: PVC
- Colour: Outside diameter: 8,5 mm  
violet (RAL 4001)

#### Mechanical and technical properties

- Min. bending radius: laid: 8 x Line diameter
- Temperature range: laid: -30°C to +80°C  
moved: -5°C to +70°C
- Burning behaviour: flame retardant based on VDE 0482, Part 265-2-1 / IEC 60332-1-2

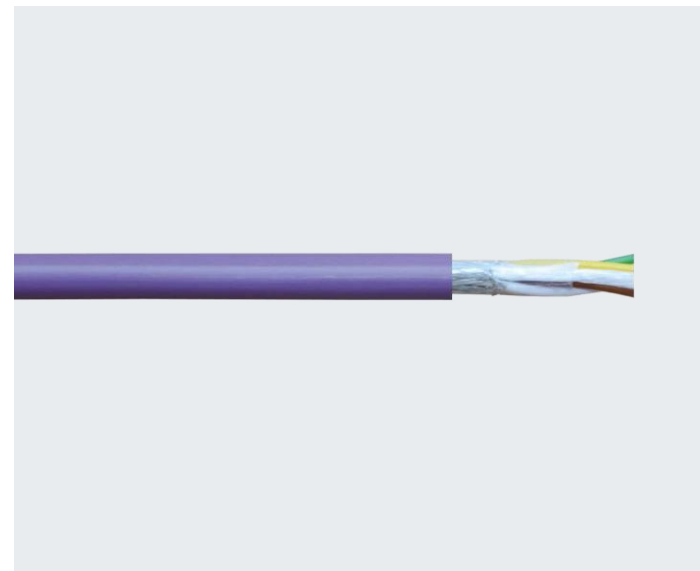

CAN-Bus-line

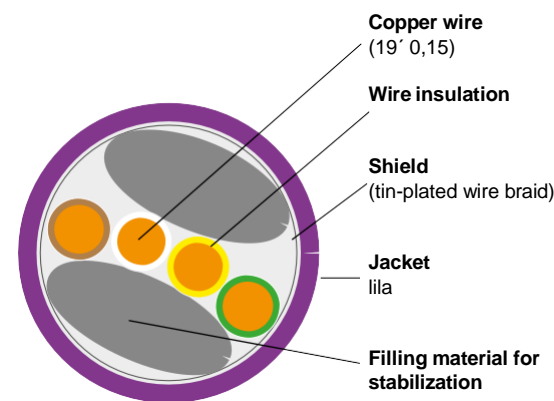

Engineering drawing

### 4. Services - Measurement

sheet

<a href="#">PROFIBUS / ASi / CAN / DeviceNet / SafetyBUS p</a>	146
<a href="#">Ethernet / PROFINET</a>	147
<a href="#">InterBus</a>	148
<a href="#">OWG</a>	149
<a href="#">EMV</a>	150
<a href="#">Wireless</a>	152

Ordering details	Art. No.
CAN-Bus-line	119050000

PROFIBUS / ASi / CAN / DeviceNet / SafetyBUS p

General

Fieldbus systems are the main artery of automation equipment. Reliability and stability guarantee an uninterrupted production. Advanced automation systems using field bus systems should be basically subject to metrological tests of the data communication quality directly after commissioning. Another essential factor to be considered in the life cycle of a machine or system is that the bus also constitutes a wear part. Besides component ageing, production-related environmental influences, e.g. coolants, lubricants, moisture and countless alternate bending stresses of bus cables, may have an impact on the life. To prevent failures, cyclic measurements of the physical and logic communication reveal the actual fieldbus quality.

Services

- Troubleshooting
- Acceptance/certification of newly installed networks
- Network analysis trouble localizing/fault analysis/fault elimination
- Commissioning support
- Consulting when it comes to planning and design and extension of networks
- Regular inspection measurements at intervals of 12 to 24 months
- Permanent network monitoring with early warning system

Using special-purpose measuring and diagnostic tools the following protocols are supported:



Scope of measurements

- Online test
  - Assessment of transmitting and receiving level (edges, harmonics, levels)
  - Assessment of logic data transfer (real cycle time, error telegrams, repeat telegrams)
- Offline test
  - Line test
  - Assessment of installation quality (Line length, wiring, resistors)
- Measuring certificate/acceptance and test record
- Recommendations on measures to be taken for system stability
- Additional offerings
  - Topology determination
  - Preparing CAD plans of network structure

Ordering details	Art. No.
Acceptance and certification Calibrating a field bus incl. test record	210010000
Troubleshooting Trouble localizing / Fault analysis / Fault elimination	210010001

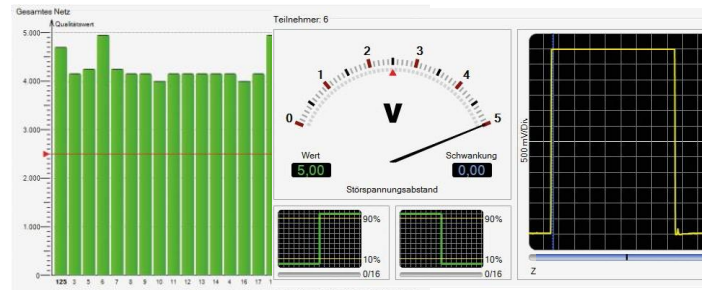

PROFI-TM Professional - Signal test for PROFIBUS

Analysis result for test without termination  
No error !

Irregularity A <-> B not determinable  
 Irregularity A <-> shield not determinable  
 Irregularity B <-> shield not determinable  
 Breakout or impedance change not determinable  
 Cable break not determinable  
 Cable OK  
 Impedance approx. 145 ohm  
 Cable length approx. 159 m

PROFtest II - Line test for PROFIBUS

Measurement report

Ethernet / PROFINET

General

Ethernet networks are becoming increasingly important in an environment close to the point of production. Other than with the office networks there is an immediate impact on the availability of the machinery and systems, and key figures such as quantity and quality. Even the most trifling communication problem becomes intolerable and requires immediate action to avoid loss of production.

Services

- Consulting in network design and upgrade
- Network planning
- Commissioning assistance
- Trouble localizing / Fault analysis / Fault elimination
- Acceptance tests and certification of new networks
- Inspections at regular intervals

Scope of measurements

- Damping measurements of Cu fiber-optic lines and issue of measurement report
- Overview on the current network (terminals, hubs, switches, network structures)
- Overview on the current IP/MAC addresses
- Telegram recordings on the applications running on the network
- Proof of network function under load (elasticity at 20% load)
- Summarizing all physical and logical measurement results as a protocol

Proactive Network Maintenance

1. Setting up custom-tailored monitoring functions of the installed network nodes (switches and hubs). The aim is to keep the customer updated at all times on the current status of the system by sending out regularly specific queries to the network nodes so that faults can be avoided and changes in the networks detected respectively at an early stage.

2a Ethernet: Installing a network management software being capable of sending out independently and irrespective of the manufacturer queries to all manageable network components, reporting events (long-term documentation) and generating warnings based on preset threshold values before those events may cause trouble. The report

network availability and requirements for a certification in accordance with DIN ISO 9001.

live data collector respectively to indicate the current condition of the communication quality within the network are the basis of a state-oriented maintenance. By storing the collected data in the device it is possible to retrieve the events any time later thus enabling a long-term

Ordering details	Art. No.
Acceptance and certification Calibrating a network incl. test record	210020000
Troubleshooting Trouble localizing / Fault analysis / Fault elimination	210020001

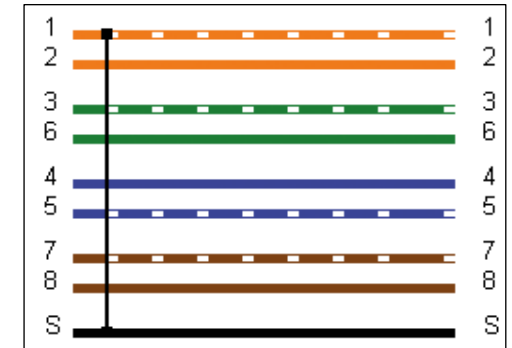

Example of short circuit on shield

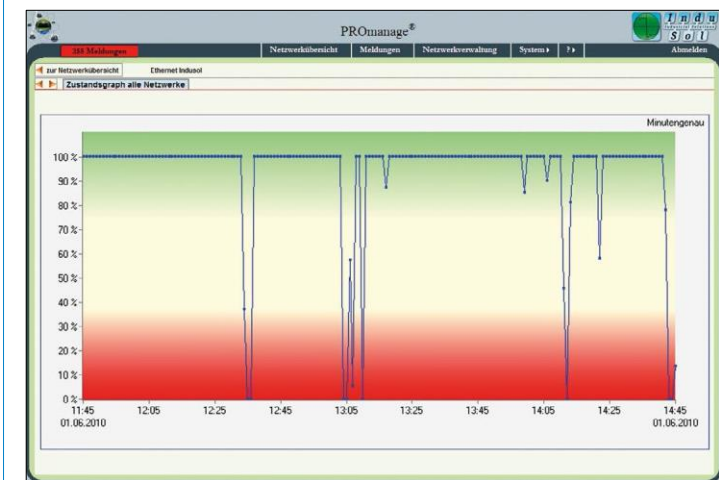

PROmanage® - State graph

## InterBus

### General

**InterBus** is a field bus system for a broad range of uses on corporate level. It covers different applications from the sensor/actor level in process automation through to the monitoring PC.

### Analysis

The analysis of the InterBus is done with the help of the statistics of the InterBus control system. The IBS-CMD software reads out the error telegrams and displays the same. The ETHERtest line test measures and evaluates the physical parameters of the connecting lines. A final analysis of the signals, for which an oscilloscope is used, visualizes interferences due to EMC or equipotential bonding problems.

### Services

- Troubleshooting
- Acceptance/certification of newly installed networks
- Network analysis trouble localizing/fault analysis/fault elimination
- Commissioning support
- Consulting when it comes to planning and design and extension of networks
- Regular inspection measurements at intervals of 12 to 24 months

### Scope of measurements

- Online test**
- Assessment of logic data transfer (real cycle time, error telegrams, repeat telegrams)
- Offline test**
- Line test
  - Assessment of installation quality (Line length, wiring, resistors)
  - Assessment of transmitting and receiving level (edges, harmonics, levels)
- Protocol**
- Measuring certificate/acceptance and test record
  - Recommendations on measures to be taken for system stability optimization
  - Planning and design support
  - Additional offerings
  - Topology determination
  - Preparing CAD plans of network structure

Ordering details

Art. No.

Troubleshooting - Acceptance - Certification

21002006

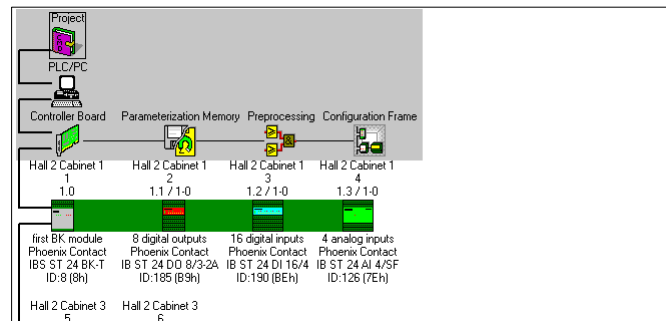

CMD-Software - Logical analysis

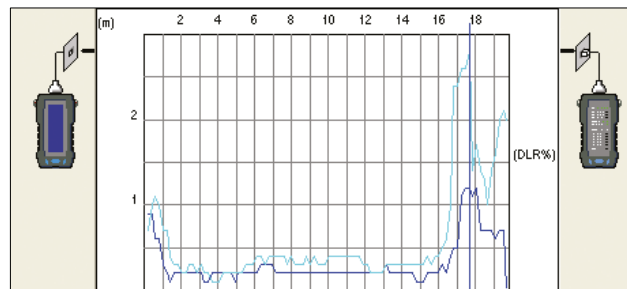

ETHERtest - Line test

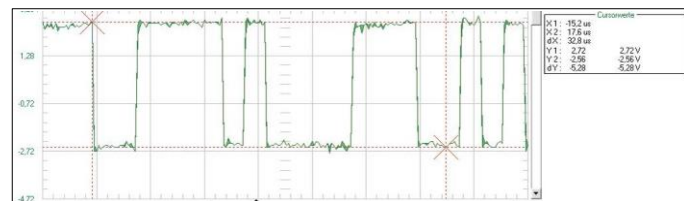

Oscilloscope - Signal test

Measurement report

## OWG

### General

Besides the fieldbus systems where data exchange takes place through electrical signals, the transfer of optical signals through **optical waveguides** (OWG) becomes more and more common in the industry. This technology is capable of bridging very long transfer distances in large automation systems.

Laying optical fibre cables requires great care. To find out whether the entire system will run reliably, the transmission link must undergo metrological testing after installation. Thus, communication disturbances can be avoided. Such checking is carried out by optical time domain reflectometry (OTDR) or transmitted-light method.

### Services

- Troubleshooting
- Acceptance / Certification of newly installed networks
- Network analysis - fault localizing / fault analysis / fault elimination
- Commissioning support

### Scope of measurements

*OTDR procedure (applicable for OWG glass fibres):*

- Possible fibre types: Multimode (gradient index), Monomode (step index)
- Attenuation over entire distance and individual sections
- Irregularities, their attenuation and location
- Length of total distance and individual sections
- Return loss of connectors

*Transmitted-light method (applicable for OWG glass and plastic fibres):*

- Attenuation over entire distance

*Measuring certificate/Acceptance and test record:*

- Recommendations on measures to be taken for system stability optimization
- Planning and design support

### OWG measuring methods

OWG type*	Fibre	Potential measurement method	
		OTDR procedure	Transmitted-light method
Monomode/step fibre 8... 10/125µm	Glass/glass	yes	yes
Multimode/gradient fibre 50/125µm 62,5/125µm	Glass/glass Glass/glass	yes yes	yes yes
Multimode/step fibre 200/280µm 200/230µm 980/1000µm	Glass/glass Glass/plastic Plastic/plastic	yes yes no	yes yes yes

\*Differing OWG types on request

Ordering details

Art. No.

Troubleshooting - Acceptance - Certification

21002007

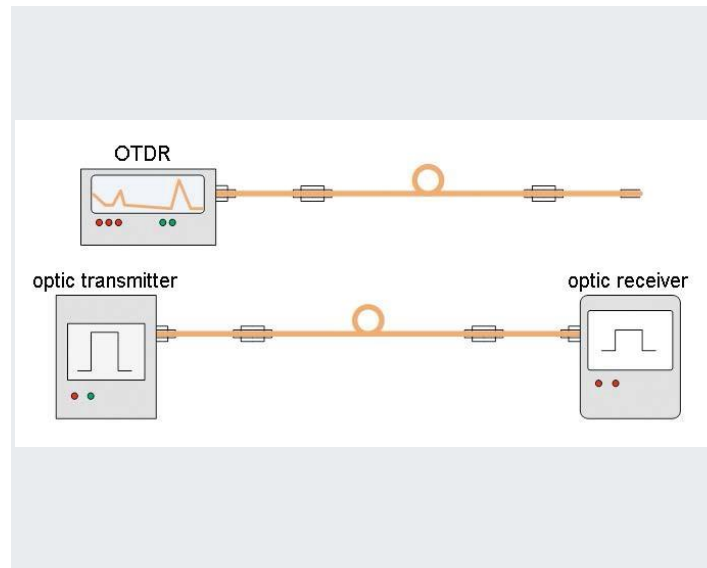

Measuring principle

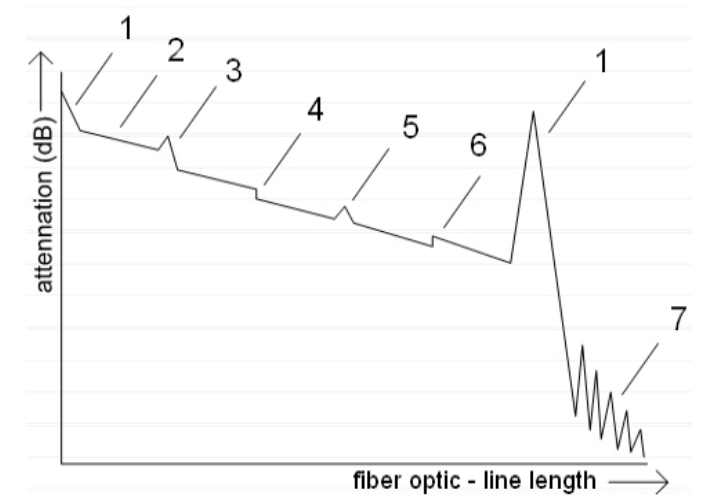

- 1 Fresnel reflection at the beginning and/or end of OWG section (step of refractive index)
- 2 Section without irregularity
- 3 Reflection and negative step
- 4 Negative steps (splice, tolerances of fibre parameters, fibre bending of insufficient radius)
- 5 Peak without attenuation (ghost reflection)
- 6 Positive step (tolerances of fibre parameters)
- 7 Noise

OTDR results

EMC

General

Just as microelectronics and power electronics get closer to each other in machines and systems the number electromagnetic (in)compatibility events is on the increase. Whilst issues of functional earthing within casings are solved satisfactorily by device manufacturers in most cases and can be verified by **EMC** measurements, the use in machines/systems under real conditions and their environment looks speaks a different language. The actually remaining EMC signal-to-interference ratio is not determined and also not documented there. Interferences find expression, for example, by faulty analogue signals, sporadic maloperation of field bus systems, control activities where nothing is to be controlled actually, etc. 80% of the faults occurring during actual operation are based on issues of functional earthing of the electronic system. It is usually rendered by a connection to the protective earth and thus a CBN (combined protection and functional equipotential bonding) created. As regards application of a CBN the EN 60204-1 states: „The functional earth may only be placed on the protective earth if its impedance and interference level are sufficiently low.“

Service

By smart long-term monitoring we listen into your system specifically in terms of EMC. It all goes without interrupting the lines to be investigated. Existing potential differences inevitably cause a current flow. Conducted interferences are detected, localized and analysed by our system solution.

- Detection of:
- transient interferences
  - stray currents
  - Impedances of PE / PA systems and shields
  - existing earth electrode network types

A detailed record makes it easy to understand the results and shows measures to reduce interferences.

Directives

\*VDE 0100-444  
EN 50310

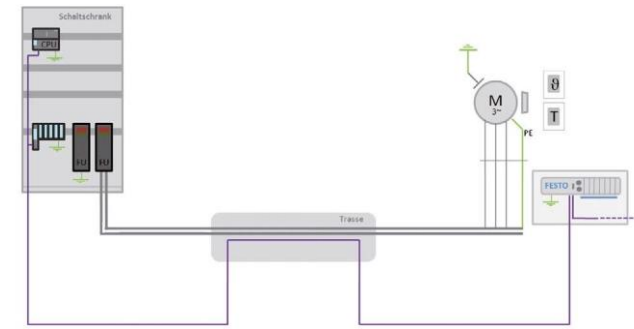

Ensuring the smooth operation of the fieldbus technology - perspectives „return current path“

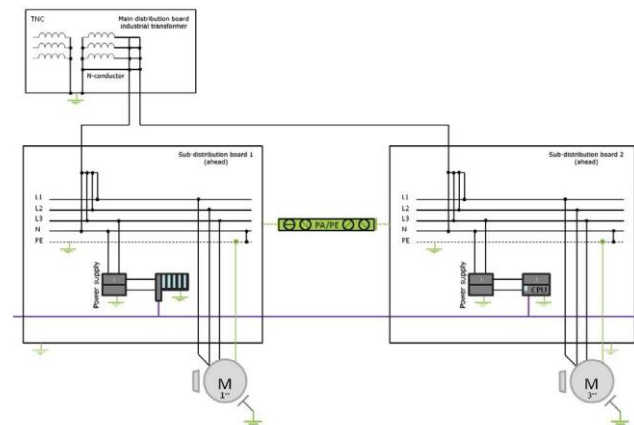

Ensuring the smooth operation of the fieldbus technology - perspectives „N-power“

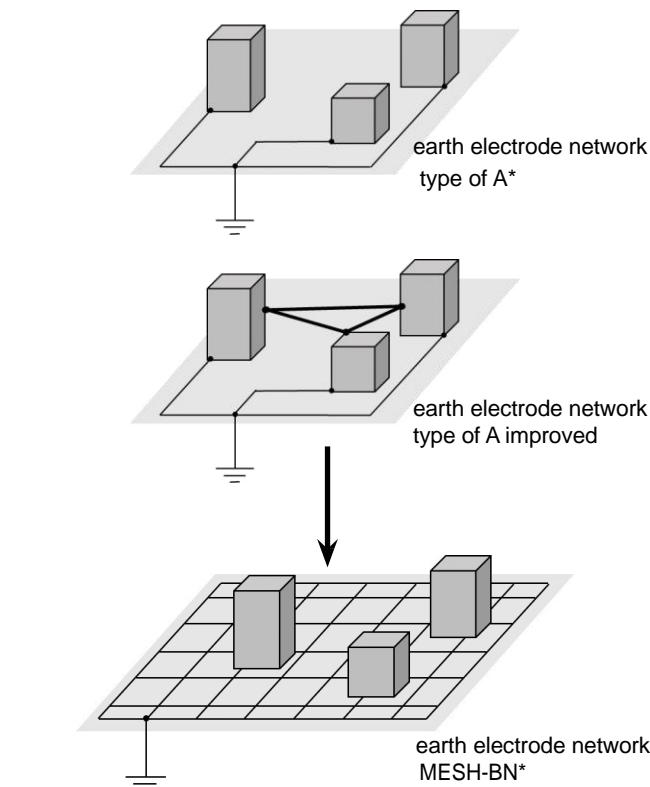

Ensuring the smooth operation of the fieldbus technology - perspectives „equipotential“

EMC

Scope of measurements

- EMC interferences along the BUS cables
- EMC interferences via the 24 VDC power supply
- EMC interferences via the 230 / 400 VAC low-voltage distribution system
- EMC interferences in the equipotential bonding system
- EMC interferences via the transmitter lines
- Quality and type of the PA system (impedances)

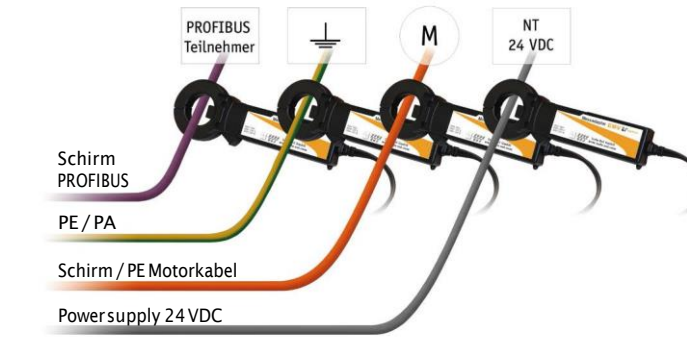

System properties

- Parallel inspections of multiple potentially disturbed sections
- Uninterrupted measurement by non-contact method
- Embedded solution of measured value processing
- Stand-alone operation after tool configuration
- Long-term monitoring based on defined thresholds
- Storage of recorded triggers in internal memories
- Connection to the INspektor® family at fieldbus errors

Network perturbations of self-commutated converters

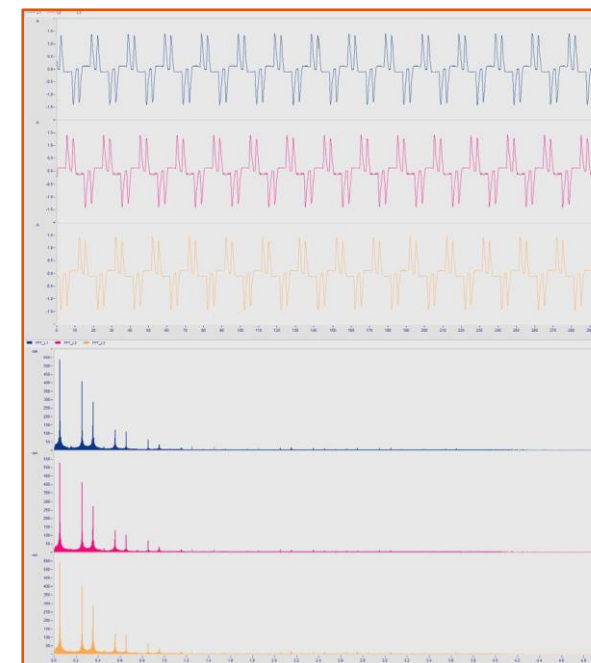

Ordering details

EMC Measurement

Art. No.

210060000

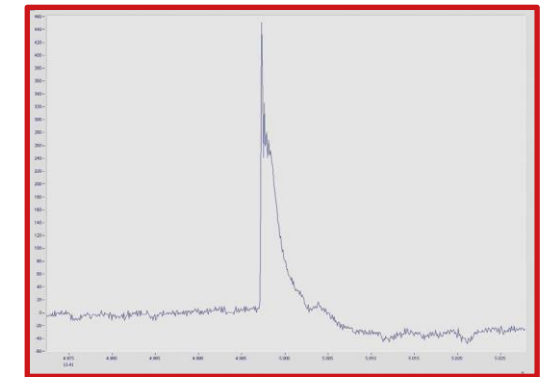

High-frequency glitch at the central supply 24 VDC



Measurement Report EMC			
Part	Messsystem	Date of Action	
<b>Customer</b>	Name Street City Country	<b>Operationplace</b>	Name Street City Country
<b>Contact person</b>		<b>Contact person</b>	
<b>Receipt Number</b>		<b>Plant</b>	
<b>Order number</b>		<b>Messsystem</b>	
<b>Details to Network</b>			
<input type="checkbox"/> TN-S	Net Typ		
<input type="checkbox"/> Netz	Power Supply from different USV		
<input type="checkbox"/> PROFIBNET	Typ of PN Cable (if available)		
<b>Measurement Tools</b>			
<b>MWVZ /</b>	<b>Loop Resistance Caliper</b>	<b>Resistance Measure</b>	
0.03	min. Resistance [Ω]	0.13	max. Resistance [Ω] of Potential Bonding
0.04	min. Resistance [Ω]	0.6	max. Resistance [Ω] of Protection Earth
0.04	min. Resistance [Ω]	1.2	max. Resistance [Ω] of Data Line
<b>LSMZ /</b>	<b>Leakage Current Caliper</b>	<b>Current Measure</b>	
3	max. measured current [A]	of Potential Bonding	
0.7	max. measured current [A]	of Protection Earth (PE)	
0.039	max. measured current [A]	of Data Line Shielding	
2	max. measured current [A]	of Neutral Conductor	
<b>EMC-INspektor</b> permanent monitoring			
Evaluation of the following			
<input checked="" type="checkbox"/>	Data Line	<input type="checkbox"/>	Potential Bonding
<input checked="" type="checkbox"/>		<input checked="" type="checkbox"/>	Protection Earth
Comments:			
<b>Evaluation</b>			
<input checked="" type="checkbox"/>	all measures are conform to		
<input checked="" type="checkbox"/>	Production Conditions		
<input checked="" type="checkbox"/>	According to EN50310		
<b>Further Recommendations</b>			
<input checked="" type="checkbox"/>	see Attachment		
Date			
Measuring Engineer			

Measurement report

**Wireless**

**General**

**Wireless** applications enjoy more and more popularity. WLAN and Bluetooth applications in particular have grown substantially in the last few years. Low material costs and no need of cabling and wear of lines especially in mobile parts of a system rouse the industry's interest in radio solutions. And last but not least the high degree of security of modern encryption methods is a good point for wireless applications in the industry.

The highly sensitive technology is subject to various interferences caused by air as the transmission medium, however. Movements, surface materials, air humidity and influences by other radio systems are only few examples of potential interferences. Therefore a proper installation, configuration and an analysis of air as the transmission medium are indispensable for wireless solutions in the industrial environment.

**Services**

Our smart measuring tools listen into your radio field. Quality problems or interferences of radio transmission are detected and measures taken for improvement. A detailed record tailored to the environment makes it easy to understand the results and shows measures to mitigate interferences.

**Analysis**

The measuring instruments used are suitable to analyse all common radio systems, such as WLAN, Bluetooth, ZigBee, DECT etc. More in-depth analyses are available for WLAN specifically. Besides a site survey an extensive logic evaluation can be done.

**Scope of measurement**

- Spectrum analysis in ISM band
- Spectrum analysis in ISM sidebands
- Level measurement of devices
- Site survey in WLAN
- WLAN planning
- Evaluation of logical data traffic in WLAN
- Optimizing the configuration

<b>Ordering details</b>	<b>Art. No.</b>
<b>Wireless Measurement</b>	<b>210080000</b>



Spektrum analysis

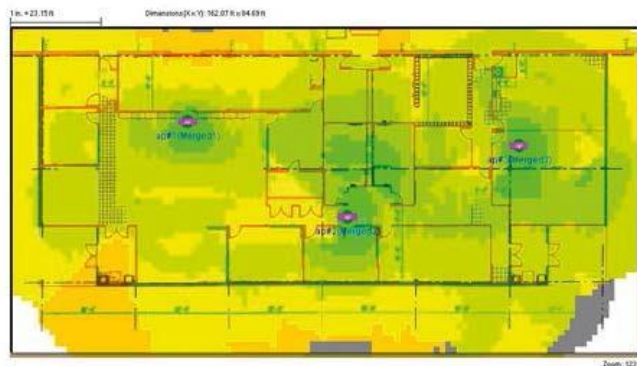

Site Survey

Measurement Record WLAN		Date of Action 12.12.2012	
Customer	Name Street City Country	Operationplace	Name Street City Country
Contact Person	Name Country	Contact Person	Name Country
Receipt Number	Plant	Order Number	Mastersystem
<b>Details of Mastersystem</b>			
<input checked="" type="checkbox"/> 8	Number of devices	<input type="text" value="37"/>	Number Accesspoints
<input checked="" type="checkbox"/> x	Infrastructuremode	<input type="text" value=""/>	Ad-Hoc-Modus
<input type="text" value=""/>	Trans-Plan/Wireless	<input type="text" value=""/>	SSID
<b>PHYSICAL CONSIDERATION</b>			
<b>Spectrum V4</b>		<b>Spectrum Analysis</b>	
<input checked="" type="checkbox"/> x	2.4 GHz ISM-Band	<input type="text" value=""/>	5 GHz ISM-Band
<input type="text" value="802.11g"/>	IEEE Standard	<input type="text" value="1,6,11"/>	Transmission Channel
<input type="text" value="-60 dBm"/>	min. signal strength	<input type="text" value="10 dBm"/>	Noise
<b>Ekahau</b>		<b>Site Survey</b>	
<input checked="" type="checkbox"/> x	durchgeführt	<input type="checkbox"/>	nichtdurchgeführt
<b>LOGICAL CONSIDERATION</b>			
<b>Air Magnet WiFi Analyser</b>		<b>Communication</b>	
<input type="text" value="54 Mbit/s"/>	Transfer rate	<input type="checkbox"/> ja	Roaming
<input type="text" value="WPA2"/>	Encryption	<input type="checkbox"/> ca. 5%	Workload
<input type="text" value="100.2"/>	TransmissionError		
<b>WIREBOUND CONSIDERATION</b>			
<b>ETHERNET / PROFIBUS / PROFINET</b>		<b>EMC-Inspection</b>	
<input type="checkbox"/>	detailed measurement and evaluation in measurement record		
<input checked="" type="checkbox"/> x	temporary / selective evaluation in measurement record		
<b>APPROVAL / CERTIFICATION</b>			
<input checked="" type="checkbox"/> x	granted	<input type="checkbox"/>	conditional granted
<input type="checkbox"/>	not granted	<input checked="" type="checkbox"/> x	Recommendation
<b>INSPECTION CRITERIA</b>			
<input checked="" type="checkbox"/> x	full filled	<input type="checkbox"/>	conditional full filled
<input type="checkbox"/>	not full filled		
Date	03.07.2013		
Engineer	Name		

Measurement report

**5. Services - Training**

sheet

Training PROFIBUS	154
Training CAN / DeviceNet / SafetyBUS p	155
Training Ethernet	156
Training PROFINET	157
Training EMV	158
Training WLAN	159

## Training PROFIBUS

### Content

The content of training is structured so that all participants of different background involved in planning / commissioning, maintenance and service can be made acquainted with the subject in a straightforward manner. All theoretical discourses are linked with practical requirements.

#### 1. Technical requirements

- „Reliable operation and maintenance of fieldbus systems“ of VDI / VDE 2184 - experience of Indu-Sol in terms in long-term safe data communication
- Laying and installation guidelines acc. to IEC 61158, IEC 61784
- Guidelines and recommendations of PROFIBUS user organisation (PNO)

#### 2. Theoretical basis

- RS 485 transfer physics / symmetrical data transfer / physical transfer principle
- Differential voltage method
- Signal form - Bit coding
- Quality characteristics of data transfer
- Clarification of the terms „Master system - Bus system“

#### 3. Logical data communication

- Protocol structure, backup mechanisms,
- Sequence of cyclical and acyclical data communication

#### 4. Cabling guidelines

- Practice-related information on installation
- Design and execution of bus topology
- Installation and assembly instructions
- Typical sources of error and their impact on handling, function and place of installation of relevant infrastructural components (repeater / diagnostic repeater DP / DP coupler, OLM, OBT)
- Drafting clear topology plans

#### 5. Quality determination in practice

- Function and handling of measuring and diagnostic tools:

**PROFtest II** - Line test  
**PROFI-TM Professional** - Quality and logic test  
**PB-INspektor®** - Warning of failure

- Determining quality characteristics
- Interpreting measuring results – troubleshooting strategy
- Conclusions and actions
- Establishing acceptance and test criteria

#### 6. Permanent fieldbus monitoring

- Condition Monitoring



Theoretical basis



Practical applications

Ordering details	Art. No.
<b>3 days at Indu-Sol internal</b> (incl. hotel accommodation per person)	<b>220010012</b>
<b>1 day at your premises external</b> (max. 6 persons)	<b>220010002</b>
<b>2 days at your premises external</b> (using a real system, max. 8 persons)	<b>220010004</b>

## Training CAN / DeviceNet / SafetyBUS p

### Content

The content of training is structured so that all participants of different background involved in planning/commissioning, maintenance and service can be made acquainted with the subject in a straightforward manner. All theoretical discourses are linked with practical requirements.

#### 1. Technical requirements

- Laying and installation standards acc. to IEC 61158
- Installation guidelines for DeviceNet according to ODVA
- „Reliable operation and maintenance of fieldbus systems“ of VDI / VDE 2184
- Experiences of Indu-Sol GmbH in long-term and safe data communication

#### 2. Physical basis

- Elements of CANBUS protocol (layers 1 and 2)
- Physical transfer principle - differential voltage method
- Signal form - Bit coding
- Quality characteristics of data transfer
- EMC / shield current issues

#### 3. Logical basis

- Communication procedure (Producer - Consumer)
- Protocol structure
- Bus access procedure - Organisation of bus communication
- CAN specification 2.0A (standard) and 2.0B (extended CAN protocol)
- Data backup mechanisms - Response to transfer errors
- Bit stuffing

#### 4. Cabling guidelines

- Practice-related information on installation
- Planning and execution of bus topology
- Installation and assembly instructions
- Typical sources of error and their impact
- Use of repeaters, bridges and gateways

#### 5. Quality determination in practice

- Function and handling of measuring and diagnostic tools: CANBUSview XL - test of line physics  
 - physical communication test  
 - logical communication test
- CB INspektor® - permanent analysis

- Determining the communication quality
- Interpreting the measuring results - troubleshooting strategy
- Conclusion and actions
- Developing acceptance and test criteria

#### 6. Permanent fieldbus monitoring

- Condition Monitoring



Theoretical basis



Practical applications

Ordering details	Art. No.
<b>1 day at Indu-Sol internal</b> (incl. hotel accommodation per person)	<b>220040003</b>
<b>1 day at your premises external</b> (max. 6 persons)	<b>220040001</b>

## Training Ethernet

### Content

- Fundamentals and definitions „IEEE 802.3, ISO / IEC 11801
- Installation, commissioning, testing, fault analysis
- Specification PROFINET acc. to PNO guidelines „PN Cabling Guide\_2252\_V200“

- 1. The common physical basis in terms of PROFIBUS**
    - Symmetrical data transfer/differential voltage signal
  - 2. Physical elements, Ethernet voltage signals**
    - Network types, network structures, network addresses
    - Fundamental of network design, line types
  - 3. Logical elements of Ethernet**
    - Ethernet in ISO / OSI reference model, telegram structure, protocols
  - 4. Measuring devices / Measuring principles / Measuring techniques**
    - Diagnosis options
    - Diagnosis through standard commands, fault localizing using switches
    - Line test, measuring records acc. to Cat. 5e,
    - Telegram recordings using Wireshark
  - 5. Acceptance conditions / Specifications**
    - Minimum requirements on network planning, installation and testing
    - Additional requirements on PROFINET networks
  - 6. Network security**
    - Basic threat scenarios: viruses, worms, unauthorized access
- Ethernet - Hands on:**  
**Installation / Commissioning / Maintenance / Troubleshooting**  
**Use of measuring devices and management tools**
- 7. Network installation**
    - The seminar participants build up a network
    - Installation of lines, plug connectors with line test record
  - 8. Network commissioning**
    - Assigning IP addresses, network commissioning
    - Installation errors and how to localize them
  - 9. Network monitoring/telegram traffic**
    - Telegram monitor Wireshark
  - 10. Switch Management and verification of impacts on network**
    - Port mirroring, Spanning Tree, Trunking, VLAN, AutoPartitioning, Port statistics
  - 11. Long-term network monitoring**
    - Network scan using PROscan®
    - Network monitoring by PROmanage® using SNMP
  - 12. Network security**
    - Isolating the built up network by security router



Theoretical basis



Practical applications

Ordering details	Art. No.
2 days at Indu-Sol internal (incl. hotel accommodation per person)	220020003
2 days at your premises external (max. 6 persons)	220020002

## Training PROFINET

### Content

- Fundamentals and definitions „IEEE 802.3, ISO / IEC 11801
- Installation, commissioning, testing, fault analysis
- Specification PROFINET acc. to PNO guidelines „PN Cabling Guide\_2252\_V200“

- 1. The common physical basis in terms of PROFIBUS**
    - Symmetrical data transfer/differential voltage signal
  - 2. Physical elements, Ethernet / PROFINET**
    - Voltage signals / Band width / bitrate / bit coding / transmission frequency / full duplex / half duplex
    - Network types
    - Network structures: line / star / ring
    - Network addresses: MAC-address, IP-address, Subnet mask
    - Fundamental of network design
    - Line types : twisted pair / fiber optics
    - Line categories: classification e.g. Cat 5e / ClassD
    - Plug connectors and Wiring diagrams: RJ45 / M12 / BFOC ST / SC
    - EMC and shield currents problems / EN 50310
  - 3. Logical elements of Ethernet / PROFINET**
    - ISO / OSI reference model
    - Telegram structure
    - Protocols: H1 (Siemens), IP, TCO/UDP, FTP, PROFINET, MAC
    - Active network components: Hub, switch, router
  - 4. Network - practice\***
    - Cable / connector / patch panel assembly
    - Network construction
    - Address assignment and commissioning
  - 5. Measuring devices / -principle / -methods / diagnostic possibilities**
    - Diagnosis through standard commands: ping, arp
    - The switch as most important point of network monitoring and troubleshooting + Managing of switches: Port statistics, log files, traps, portmirroring
    - Line test using ETHERtest®, Setting a measurement protocol to Cat 5e
    - Telegram recordings using ETHERtest® / Wireshark
    - Manufacturer-independent long term network monitoring using PROmanage® and PROInet-INSpektor®
    - Manufacturer-independent network scanner PROscan®
- \*To 4. Practice**
- Network installation
  - Network commissioning
  - Network monitoring/telegram traffic
  - Switch Management and verification of impacts on network
  - Long-term network monitoring
  - Network security



Theoretical basis



Practical applications

Ordering details	Art. No.
2 days at Indu-Sol internal (incl. hotel accommodation per person)	220030001
2 days at your premises external (max. 6 persons)	220030000

## Training EMV

### Content

Our experience has shown that there is much need for awareness raising when it comes to EMC aspects in the environment of field bus systems because the lack of knowledge may have adverse effects also including shock protection. By observing clear guidelines and the resulting measures it can be avoided. With comprehensible explanations based on fundamental knowledge in electrical engineering skills learned can be properly applied in practice.

The content of training is structured so that all participants of electro-technical background involved in planning / commissioning, maintenance and service can be made acquainted with the subject in a straightforward manner.

In addition to the required theoretical knowledge practical tests based on comprehensible measured values build an understanding for the issues that can be applied in practice right away.

### 1. Basics

- Overview on applicable norms (EN50310)
- Definition and delimitation
- Network types (TN-C, TN-S, IT), equipotential, Grounding, shielding, EMC, high frequency, low frequency
- Basics electromagnetic field
- Basics equipotential / Grounding

### 2. Typical interferences

### 3. LV distribution boards and equipotential bonding

### 4. Frequency converter

- Where do low-frequency currents on shielded lines typically come from?
- Where do high-frequency currents on shielded lines typically come from?

### 5. Shielding

- Operation principle of a shield for protection against electromagnetic fields
- Principle and differences between shielding FU-line / signal line

### 6. Measurement devices

- Measurement devices and practical measurements

### 7. Measurement methods

### 8. Measures to improve EMC

- Appropriate countermeasures
- Empirical values of Indu-Sol in terms of a long-term, safe data communication



Theoretical basis



Practical applications

Ordering details	Art. No.
2 days at Indu-Sol internal (incl. hotel accommodation per person)	220060002
2 days at your premises external* (max. 6 persons)	220060001

\*) The practical part of the experimental setup is feasible only for internal training

## Training WLAN

### Content

The training has been structured so that all participants interested in radio transmissions are made acquainted with the WLAN subject in an easy to understand and straightforward manner. The objective is to provide persons working in the areas of planning, commissioning, maintenance and service with the necessary knowledge to enable them to build up WLAN systems and evaluate the quality of the same. Prior knowledge of Ethernet/LAN would be desirable.

### 1. Fundamentals of radio engineering

- Electromagnetic waves
- Antenna technology
- Applications
- ISM bands

### 2. Fundamentals of WLAN

- Development of WLANs
- Applicable regulations and directions
- WLAN standards „IEEE 802.11 a / b / g / h / n“
- Basic concepts and network types
- Mode of operation
- Security and encryption

### 3. Planning and start-up

- Planning by applications and environments
- Co-existence of different radio networks
- Product selection
- Configuration and start-up

### 4. Measuring devices and diagnosis

- Diagnosis using the existing infrastructure
- Site survey
- Spectrum analysis
- Logical analysis
- Troubleshooting



Theoretical basis



Practical applications

Ordering details	Art. No.
2 days at Indu-Sol internal (incl. hotel accommodation per person)	220080001
1 day at your premises external (max. 6 persons)	220080000



Архангельск (8182)63-90-72  
Астана (7172)727-132  
Астрахань (8512)99-46-04  
Барнаул (3852)73-04-60  
Белгород (4722)40-23-64  
Брянск (4832)59-03-52  
Владивосток (423)249-28-31  
Волгоград (844)278-03-48  
Вологда (8172)26-41-59  
Воронеж (473)204-51-73  
Екатеринбург (343)384-55-89  
Иваново (4932)77-34-06

Ижевск (3412)26-03-58  
Иркутск (395)279-98-46  
Казань (843)206-01-48  
Калининград (4012)72-03-81  
Калуга (4842)92-23-67  
Кемерово (3842)65-04-62  
Киров (8332)68-02-04  
Краснодар (861)203-40-90  
Красноярск (391)204-63-61  
Курск (4712)77-13-04  
Липецк (4742)52-20-81  
Киргизия (996)312-96-26-47

Магнитогорск (3519)55-03-13  
Москва (495)268-04-70  
Мурманск (8152)59-64-93  
Набережные Челны (8552)20-53-41  
Нижний Новгород (831)429-08-12  
Новокузнецк (3843)20-46-81  
Новосибирск (383)227-86-73  
Омск (3812)21-46-40  
Орел (4862)44-53-42  
Оренбург (3532)37-68-04  
Пенза (8412)22-31-16  
Казахстан (772)734-952-31

Пермь (342)205-81-47  
Ростов-на-Дону (863)308-18-15  
Рязань (4912)46-61-64  
Самара (846)206-03-16  
Санкт-Петербург (812)309-46-40  
Саратов (845)249-38-78  
Севастополь (8692)22-31-93  
Симферополь (3652)67-13-56  
Смоленск (4812)29-41-54  
Сочи (862)225-72-31  
Ставрополь (8652)20-65-13  
Таджикистан (992)427-82-92-69

Сургут (3462)77-98-35  
Тверь (4822)63-31-35  
Томск (3822)98-41-53  
Тула (4872)74-02-29  
Тюмень (3452)66-21-18  
Ульяновск (8422)24-23-59  
Уфа (347)229-48-12  
Хабаровск (4212)92-98-04  
Челябинск (351)202-03-61  
Череповец (8202)49-02-64  
Ярославль (4852)69-52-93

<https://indusol.nt-rt.ru/> || [nsc@nt-rt.ru](mailto:nsc@nt-rt.ru)